

# *ECE137A Notes Set 1: Bipolar Transistors Characteristics*

*Mark Rodwell*

*University of California, Santa Barbara*

rodwell@ece.ucsb.edu

# Why study bipolar transistors ?

MOSFETs are now much more common, being 99.999% dominant in digital ICs, and probably 95% of analog ICs. Bipolar transistors are however still used in faster high resolution analog - digital converters, and used widely in radio frequency and optical communications ICs.

Quality mosfets are also very difficult to obtain in the discrete form needed for the lab projects. Insofar as they are available, the data sheets give very limited design information. It is therefore very difficult to design satisfactory lab projects using MOSFETs. Quality discrete bjts are widely available, and their charactersitics are such that only limited information is needed for data sheets.

# Terminal Characteristics: NPN bipolar transistor

for  $V_{cb} > 0$

(collector base junction reverse biased)

$$I_E = I_{es} \left( e^{V_{be}/V_T} - 1 \right)$$

$$I_b = I_E / \beta$$

where

$$V_T = kT / q = 25.8 \text{ mV at } 300 \text{ Kelvin (room temperature)}$$

$V_T$  is called the "thermal voltage"

$$k = \text{Boltzmann's constant} = 1.38(10^{-23}) \text{ Joule/Kelvin}$$

$T$  = absolute temperature

$$q = \text{electron charge} = 1.6022(10^{-19}) \text{ Coulomb}$$

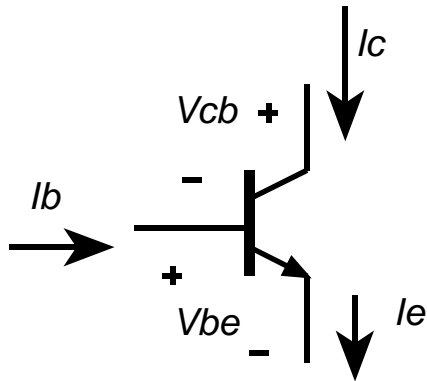

# Terminal Characteristics: PNP bipolar transistor

For the PNP bipolar transistor, current directions and voltage polarities are simply reversed.

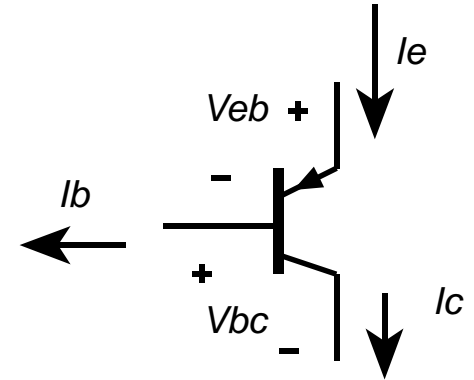

Again, if the collector base junction is reverse biased

( $V_{bc} > 0$ ), then

$$I_E = I_{es} \left( e^{V_{eb}/V_T} - 1 \right)$$

$$I_b = I_E / \beta$$

# Voltage Polarities and Notation

You may have been taught the notation to the right, where  $V_{be} = V_b - V_e$  and  $V_{cb} = V_c - V_b$

This leads to  $V_{be} = -V_{eb}$ .

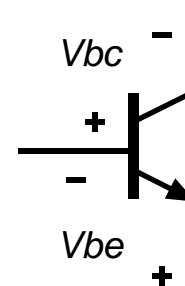
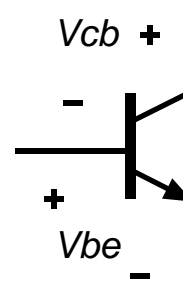

Although this is the standard textbook notation, it is often difficult to keep polarities correct. Instead, I recommend defining the polarity of voltages by drawing + and - signs on the circuit diagram associated with any variable defining a voltage. Further, whenever possible, DC voltage and current variables are defined so their values are **POSITIVE** when the transistor is operated normally.

# Polarities of voltages: NPN and PNP

A diode is forward biased if the P - side is more positive than the N - side.

A forward - biased diode conducts significantly.

Conventional (Ben Franklin) current flows from P to N in a forward - biased diode.

Electrons, being negative, move from N to P

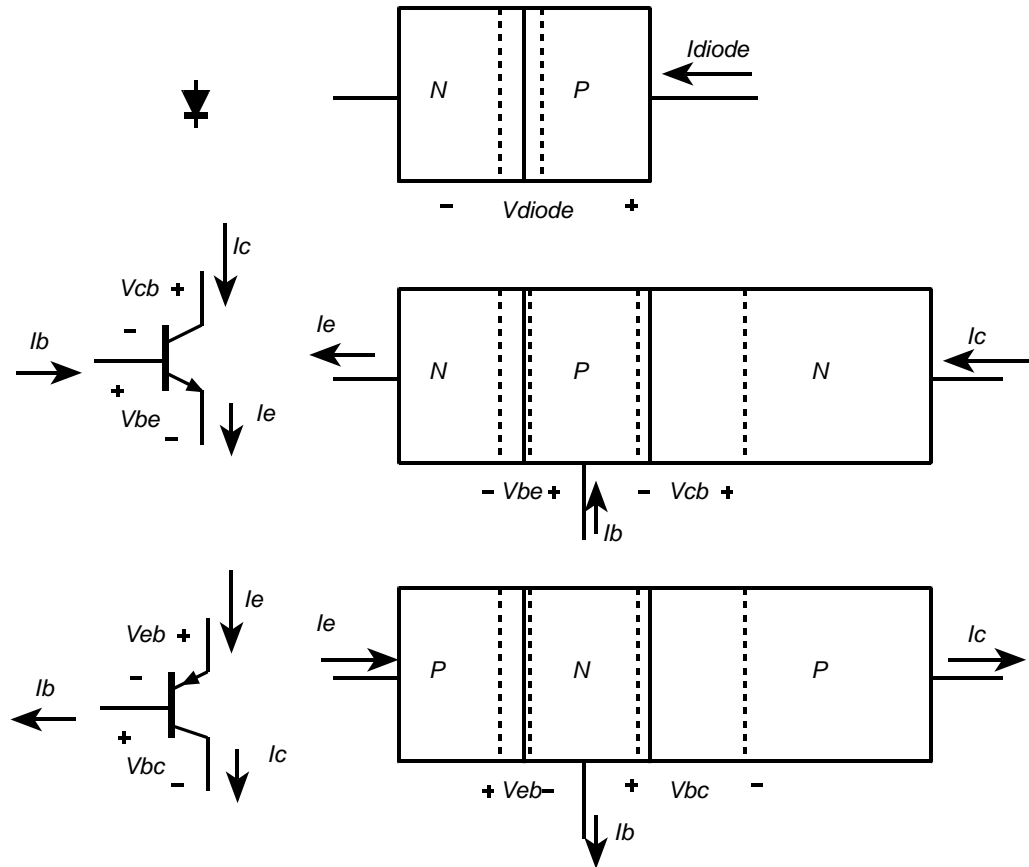

# Polarities of voltages: NPN and PNP

In a normally - operating BJT  
 the base - emitter junction  
 is forward - biased,  
 and the base - collector junction  
 is reverse - biased.

By this rule, we can determine  
 the correct voltage polarities  
 and current directions.

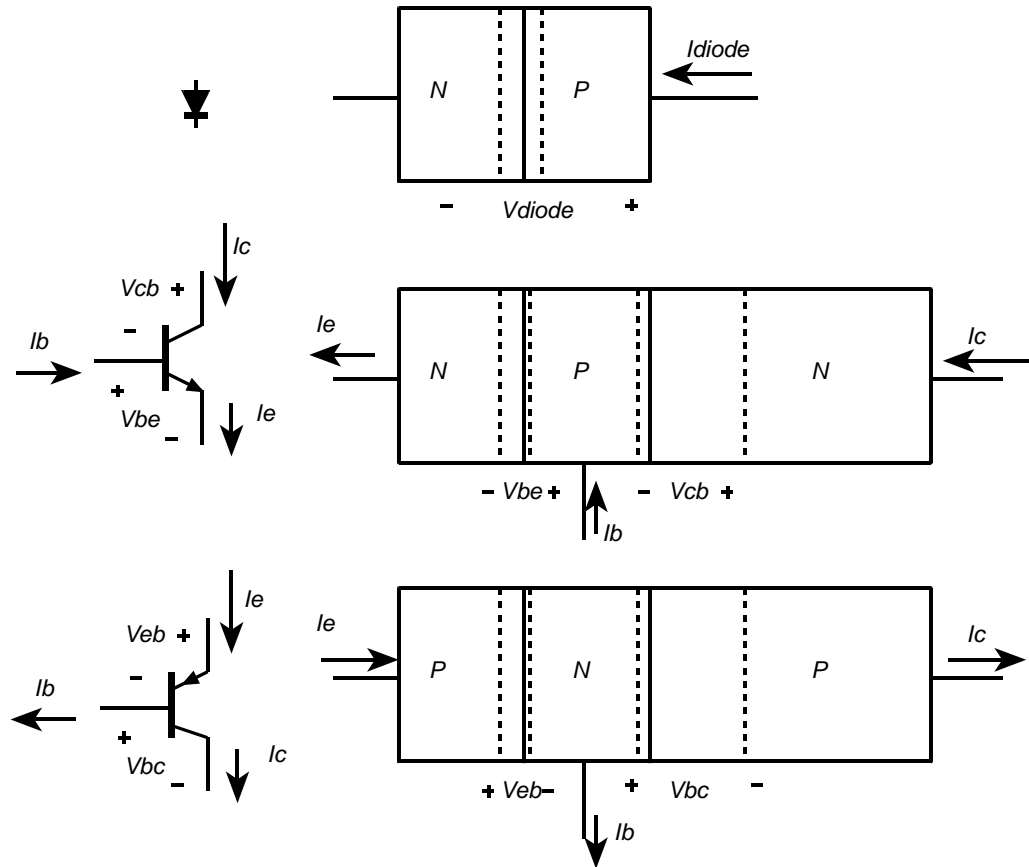

# Common-emitter current gain $\beta$ or $H_{FE}$

The collector voltage  $V_C$  is made sufficiently positive, forcing  $V_{cb} > 0$  (reverse - biased collector - base junction).

Common - emitter current gain

$$\frac{I_C}{I_B} = \beta = H_{FE}$$

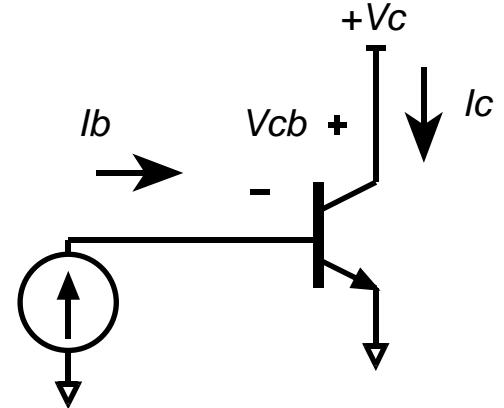

# Common-base current gain $\alpha$

The collector voltage  $V_C$  is made positive, forcing  $V_{cb} > 0$  (reverse - biased collector - base junction).

Common - base current gain

$$\alpha \equiv \frac{I_C}{I_E} = \frac{I_C}{I_C + I_B} = \frac{I_C / I_B}{(I_C / I_B) + 1}$$

$$\Rightarrow \alpha = \frac{\beta}{\beta + 1} \text{ or } \beta = \frac{\alpha}{1 - \alpha}$$

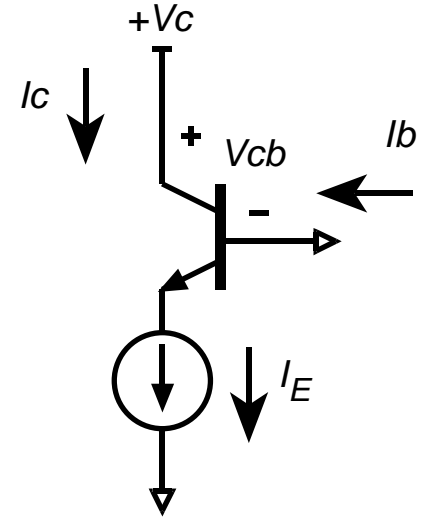

# Typical values of DC current gain

This can vary tremendously.

General - purpose BJTs used in Analog - digital converters  
and similar circuits :  $\beta \cong 300 - 500 \rightarrow \alpha \cong 0.997 - 0.998$

Jellybean 2N3904 - 2N3906 BJTs used in lab projects :  
 $\beta \cong 50 - 300 \rightarrow \alpha \cong 0.95 - 0.997$

Specialized (power, microwave, ...) transistors  
 $\beta \cong 20 - 200 \rightarrow \alpha \cong 0.95 - 0.998$

# Common-base DC characteristics

A fixed value of emitter current  $I_E$  is applied, and  $V_{CB}$  is varied. The collector current  $I_C$  and the base-emitter voltage  $V_{BE}$  are measured.

The emitter current is then changed to a new value,  $V_{CB}$  again varied and  $I_C$  and  $V_{BE}$  again measured

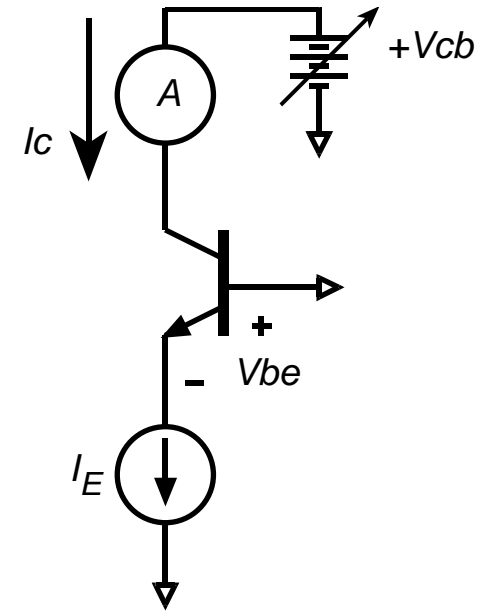

# Common-base DC characteristics

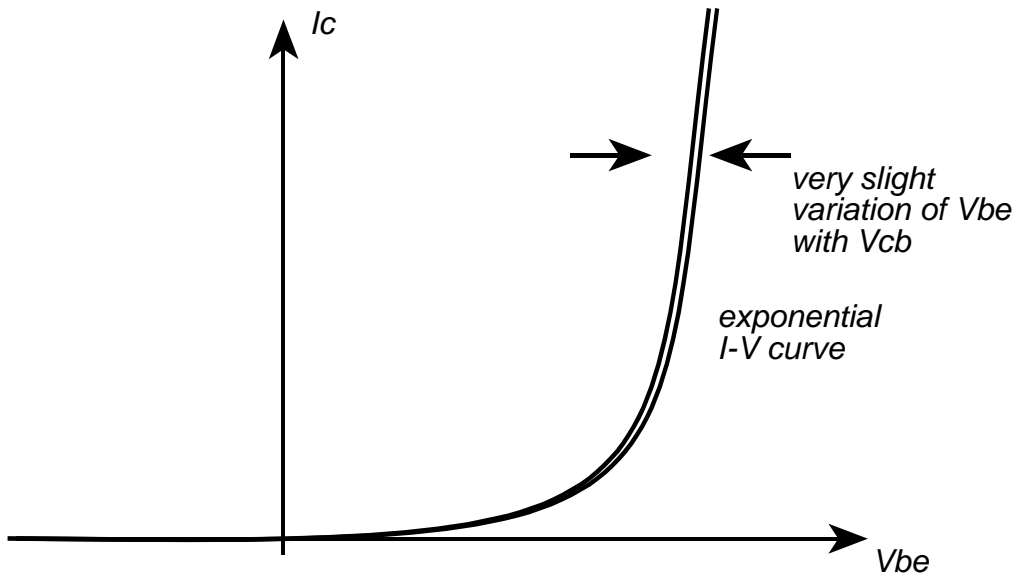
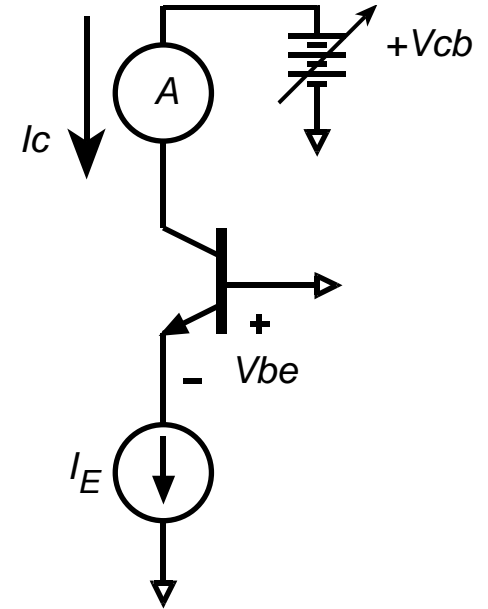
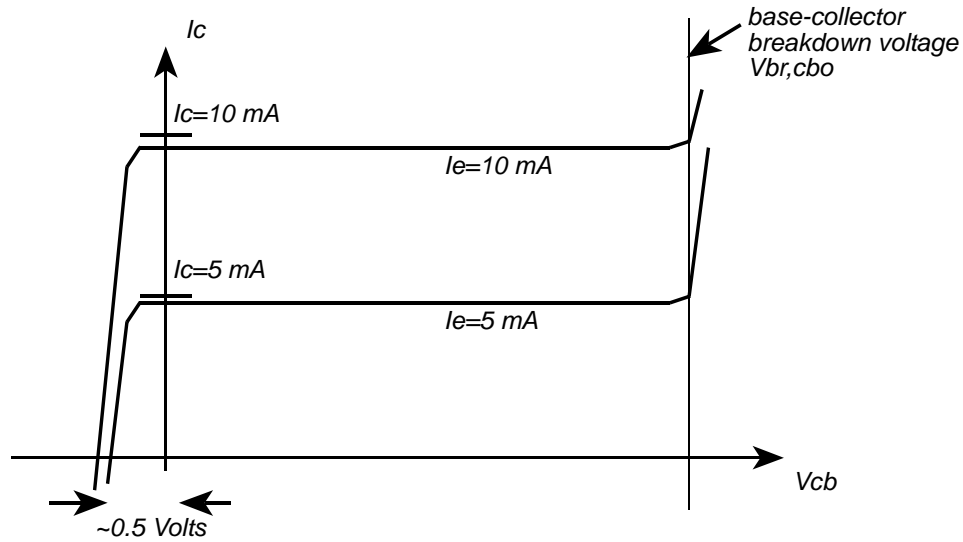

# Base-emitter voltage

$$V_{be} = V_T \ln\left(\frac{I_E}{I_{ES}} + 1\right) \cong V_T \ln\left(\frac{I_E}{I_{ES}}\right) \Leftarrow \text{actual relationship}$$

$$V_{be} = V_{be,on} \Leftarrow \text{rough approximation}$$

$V_{be,on}$  is typically in the range of 0.6-0.7 volts for 60's - vintage BJTs used in the lab, 0.8-0.9 volts for 2000 - vintage devices.

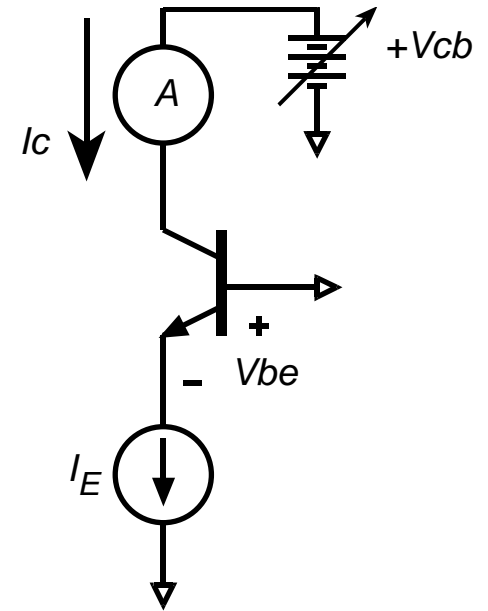
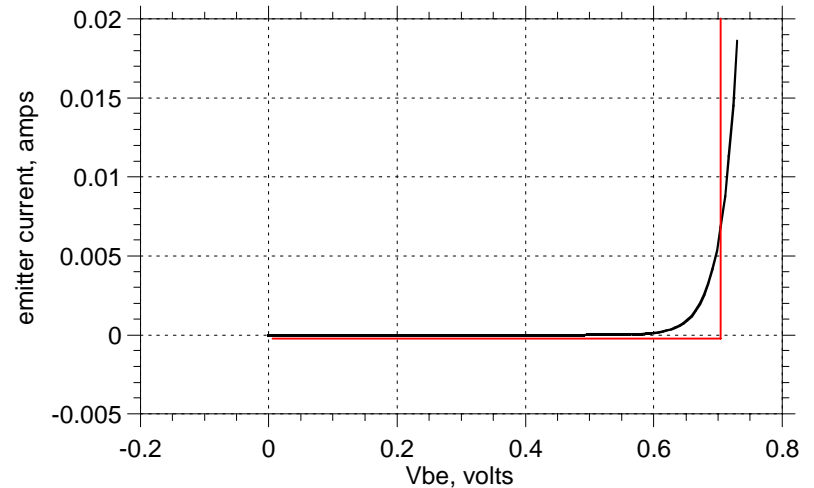
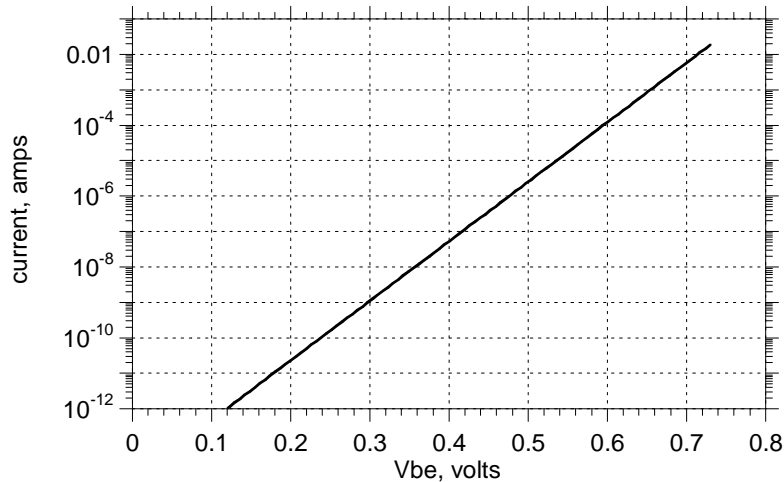

# Common-base curves measured on a microwave BJT

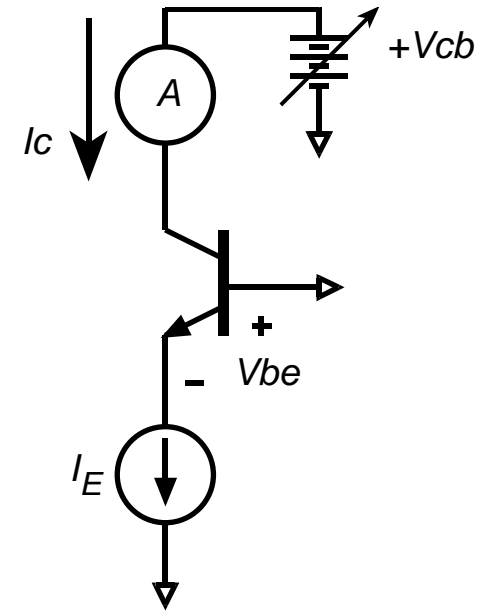
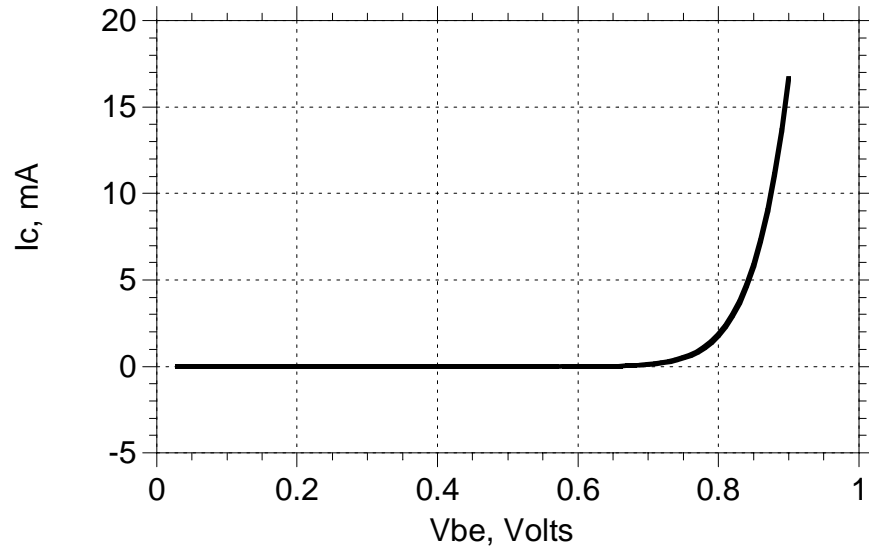
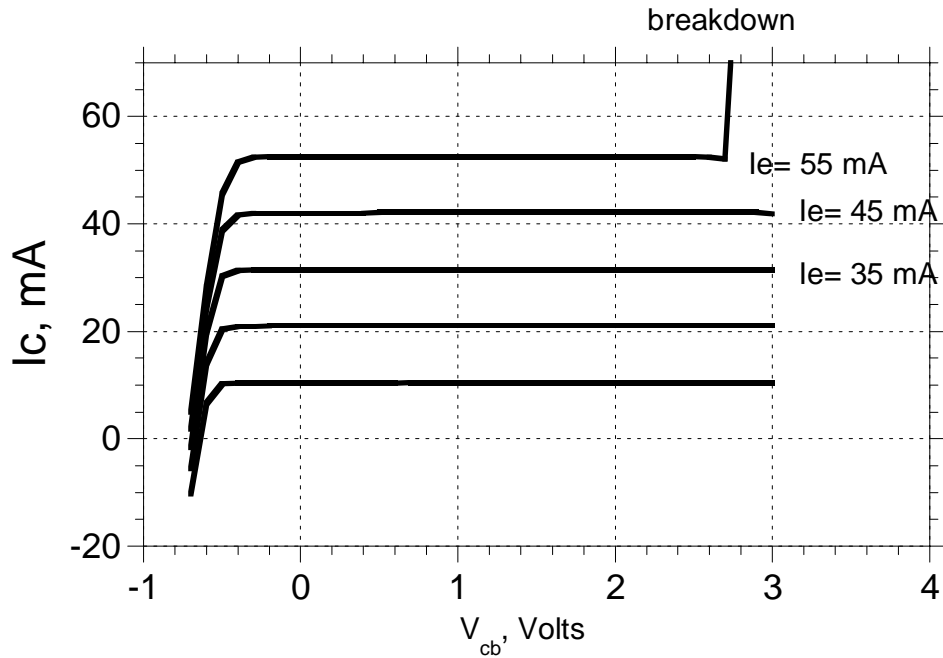

# PNP Transistor: common-base DC characteristics

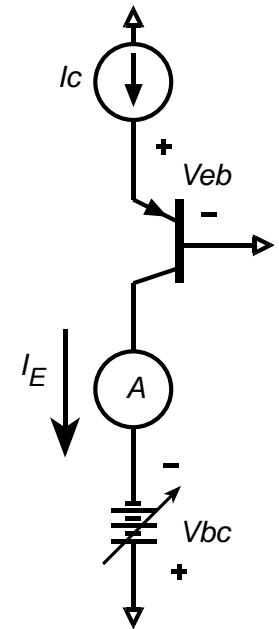
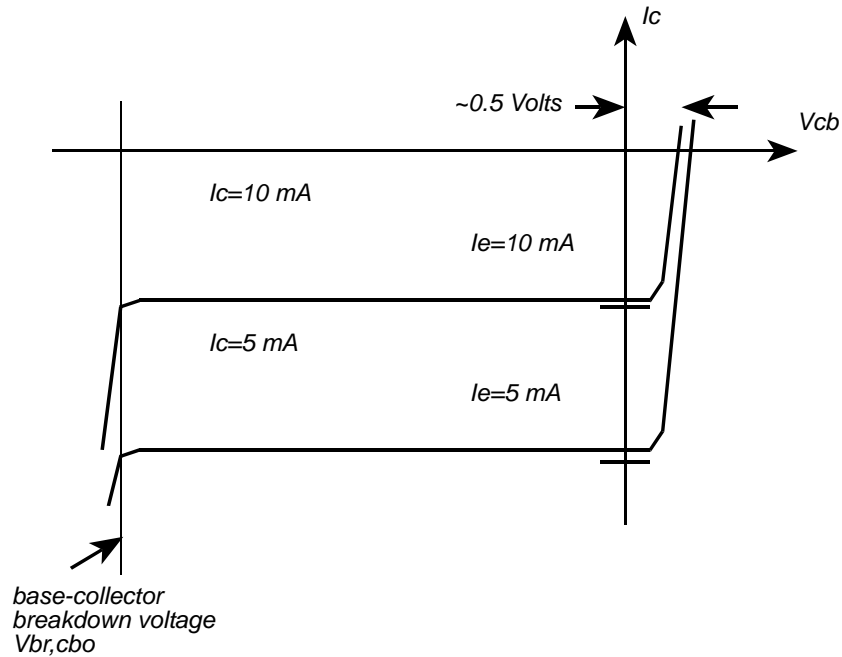

Plots of PNP characteristics are standard in texts.

In practice, we use them infrequently.

The most important point is to remember the correct polarities of voltages and the correct directions of currents.

# Common-Emitter DC characteristics

In the linear region,  $I_c \cong \beta \cdot I_b$

There is also some variation of  $I_c$  with collector voltage.

This is called the Early effect.

The slope of the curve  $dI_c / dV_{CE} \sim \frac{I_c}{V_{CE} + V_A}$

$V_A$ , the Early voltage, is typically 50 - 100 V

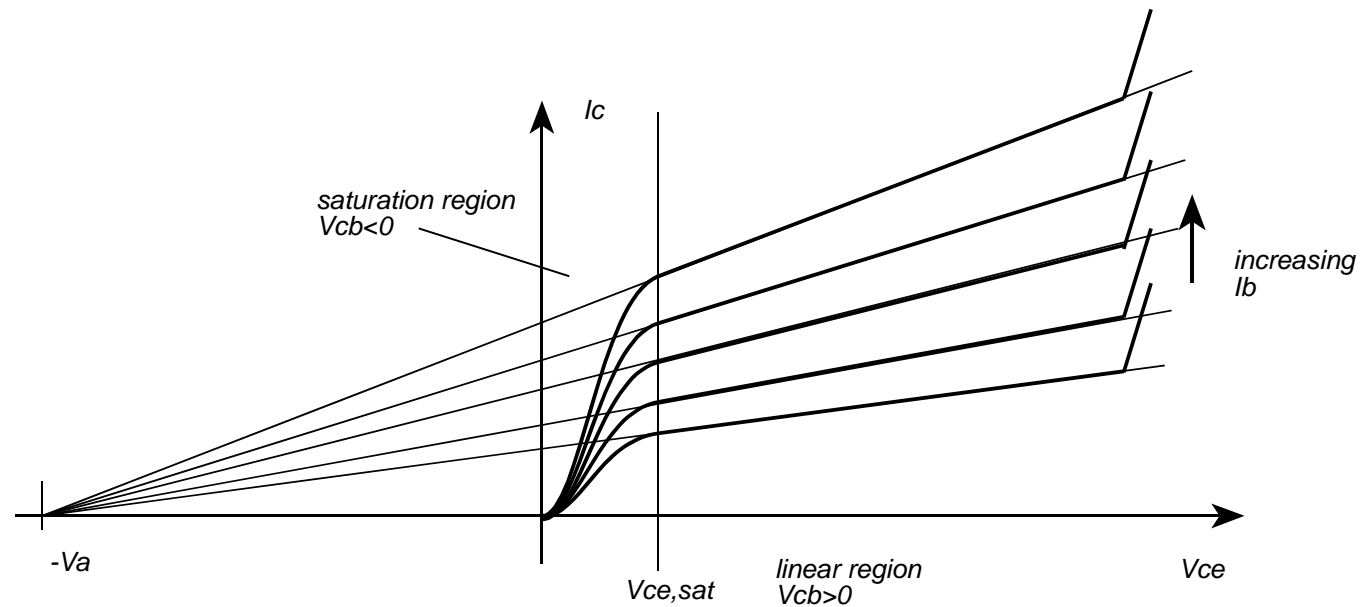
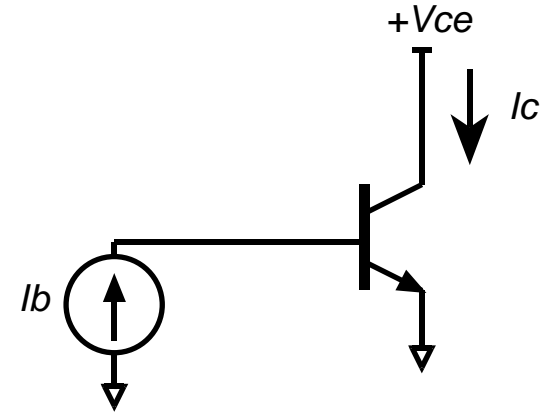

# Common-emitter curves measured on a microwave BJT

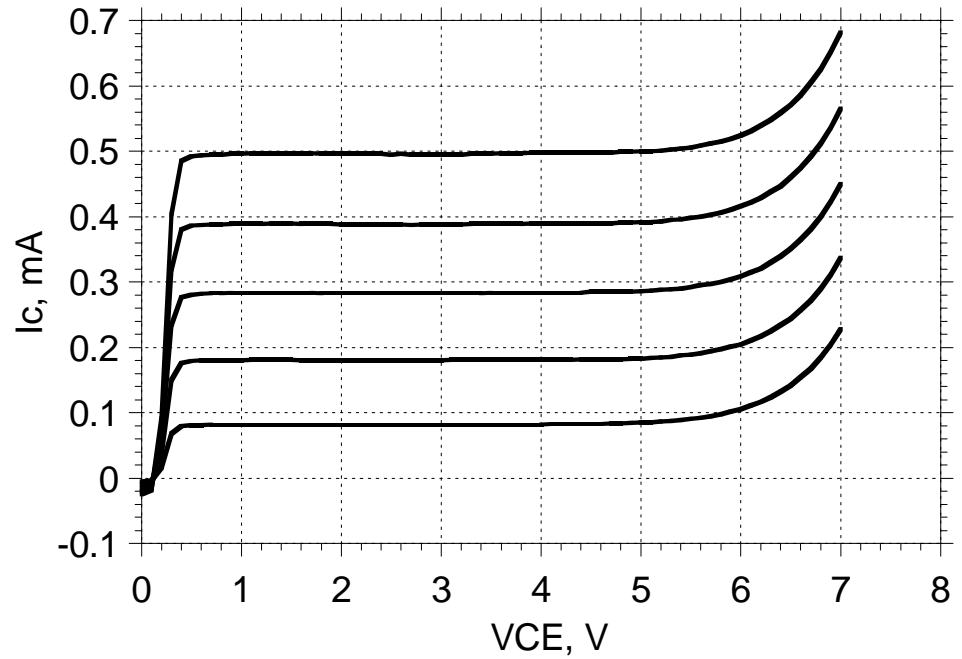
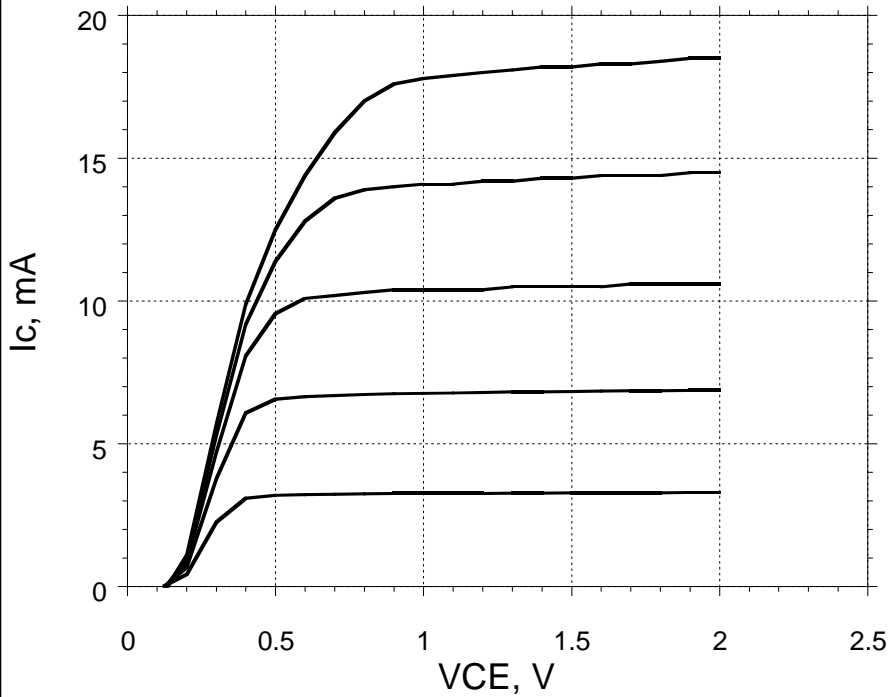

Above curves are for 150,300,450,600,750  $\mu\text{A}$  base current

# Modes of operation: Linear Active

The BJT has 2 PN junctions. Each can be forward or reverse - biased. The 4 combinations give us 4 modes of operation

## Linear Active Mode :

Normal mode of operation for linear amplification

BE junction forward biased

BC junction reverse biased

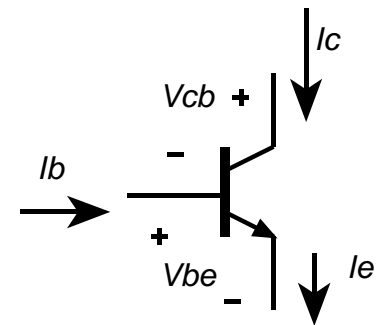
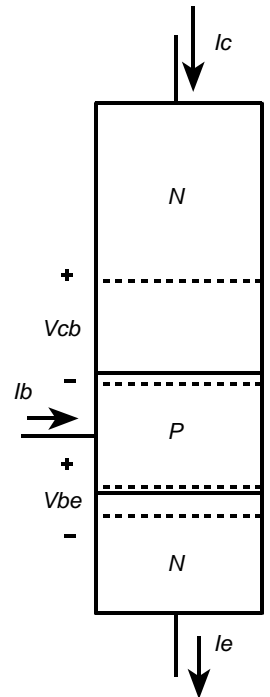
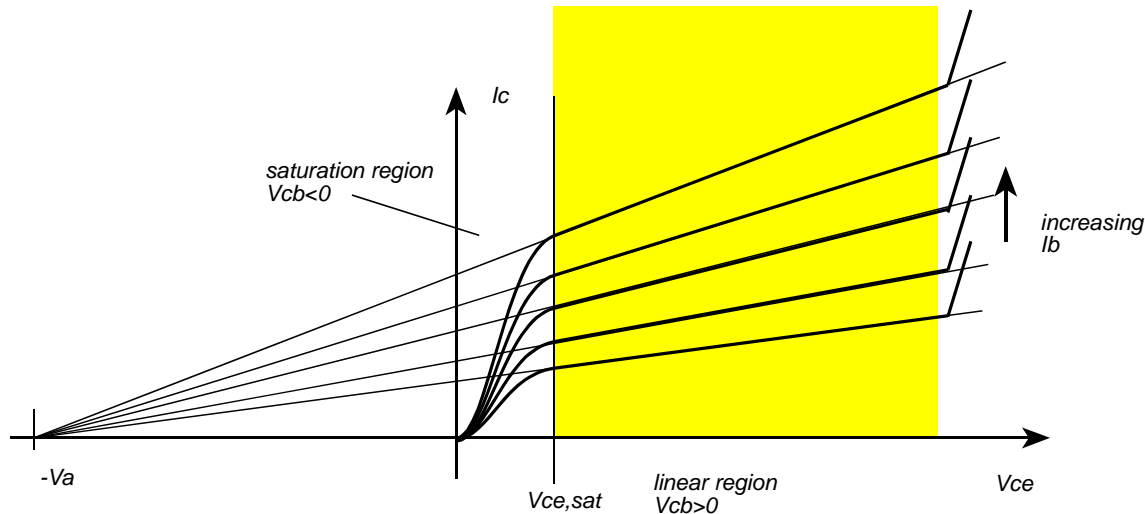

# Modes of operation: Saturation

Saturated

BE junction forward biased

BC junction forward biased

Sometimes used deliberately when we want a low - voltage switch.

Saturation is one limit on the maximum voltage swing of the transistor used as an amplifier

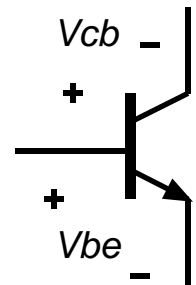
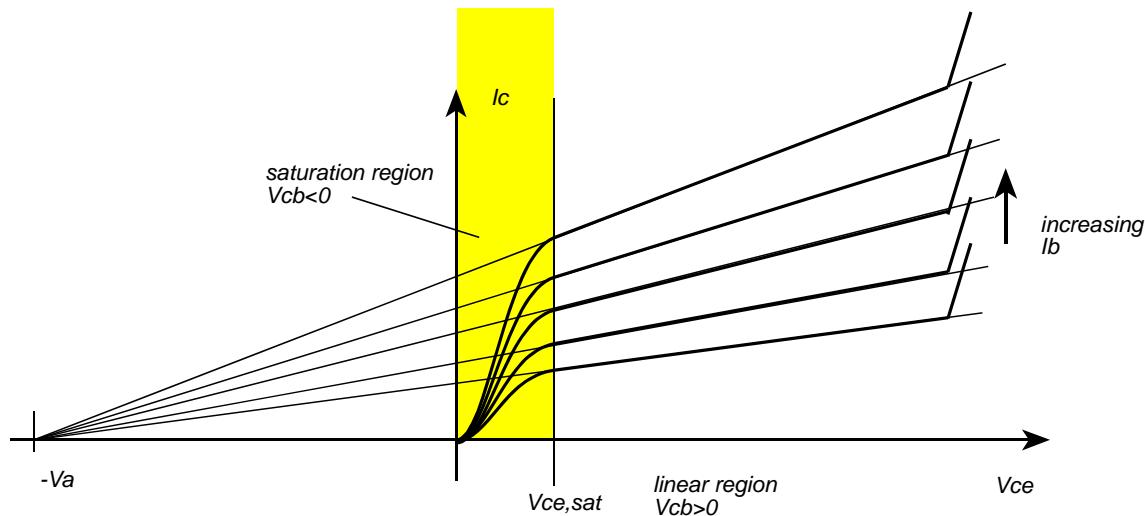

# Modes of operation: Cutoff

Cut off

BE junction reverse biased, or not sufficiently forward biased to turn junction on.

BC junction reverse biased

If the base - emitter voltage is too small (barely forward biased) then the emitter current will be near zero.

The transistor is off.

Cutoff is a second limit on the maximum voltage swing of the transistor used as an amplifier.

There is also a reverse active mode, in which the BE junction is reverse biased and the BC junction is forward biased. The transistor then operates similarly to the forward active mode, but with very low current gain.

# DC model for bias analysis

Use either

$$V_{be} = V_{be(on)} \quad (\text{quick})$$

$$V_{be} = V_T \ln(I_E / I_{ES}) \quad (\text{more accurate})$$

the 2nd relationship is necessary for current mirrors and for bias currents in push - pull and similar stages.

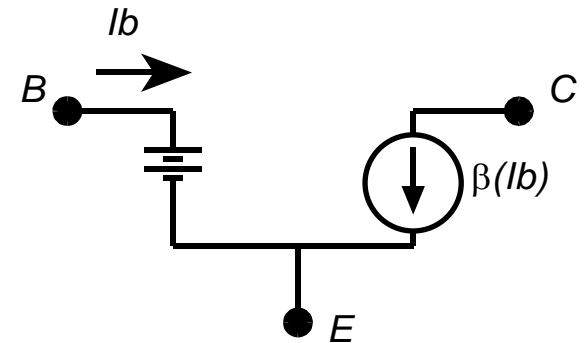

# AC small-signal model

First find  $g_m$  :

$$g_m v_{be} = \beta I_b$$

$$g_m \equiv \left. \frac{\partial I_c}{\partial V_{be}} \right|_{V_{ce} \text{ constant}}$$

$$\text{but } I_c = \alpha I_{ES} (e^{V_{be}/V_T} - 1) \cong \alpha I_{ES} e^{V_{be}/V_T}$$

hence

$$\left. \frac{\partial I_c}{\partial V_{be}} \right|_{V_{ce} \text{ constant}} = \frac{I_c}{V_T}$$

$$g_m = I_c / V_T = \alpha / r_e \cong 1 / r_e$$

Note we have defined  $r_e$  the "small signal emitter resistance"

$$r_e = V_T / I_E = 26mV / I_E \text{ at room temperature.}$$

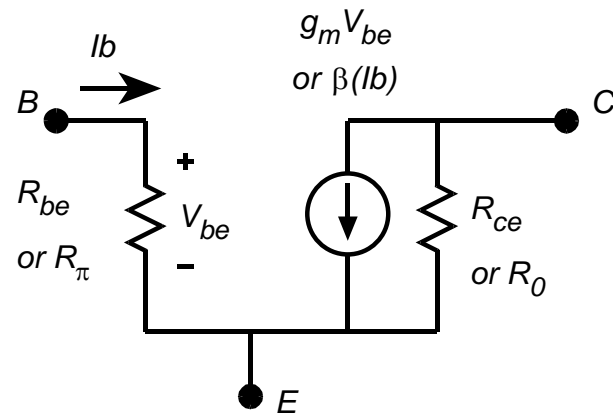

# AC small-signal model

Now find  $R_\pi$  or  $R_{be}$  :

$$(R_{be})^{-1} \equiv \left. \frac{\partial I_b}{\partial V_{be}} \right|_{V_{ce} \text{ constant}}$$

But  $I_b = I_c / \beta$  and  $I_c = g_m V_{be}$  so  $I_b = g_m V_{be} / \beta$

Now find  $R_0$  or  $R_{ce}$  :

$$(R_{ce})^{-1} \equiv \left. \frac{\partial I_c}{\partial V_{ce}} \right|_{V_{be} \text{ constant}}$$

Best to find from a curve - tracer or from a data sheet

Estimate from :

$$\left. \frac{\partial I_c}{\partial V_{ce}} \right|_{V_{be} \text{ constant}} = \frac{I_{c,bias}}{V_{CE,bias} + V_A}$$

$$\rightarrow R_{ce} = \frac{V_{CE,bias} + V_A}{I_{c,bias}}$$

