

### First test

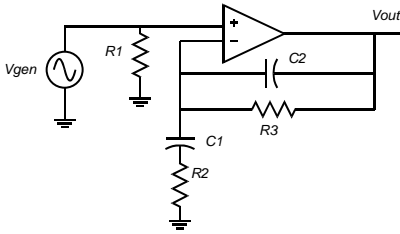

First test circuit:

Use this circuit not only to test the closed loop frequency response but also when you are checking general DC bias conditions and correct functional circuit operation.

If you ground the input (set  $V_{gen}=0$ ), the DC output voltage is equal to the amplifier DC offset voltage. That value you will need to know for the next measurement.

$R_1$  should be  $\sim 10$  kOhm. The other component values you will need to calculated.

### second test

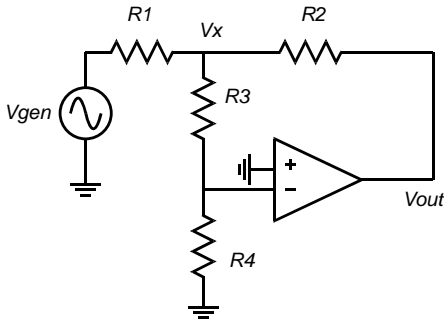

Use this circuit when you need to measured the low-frequency open-loop gain of an op-amp. Make  $R_1=R_2=10$  kOhm. Lets leave  $R_3$  and  $R_4$  unspecified for a moment.

Apply an AC input signal  $V_{gen}$  as indicated. Adjust the generator amplitude until the output is 1 Volt peak-peak. Measure the amplifier output voltage and the voltage at the point labeled  $V_x$ . The op-amps open-loop gain is then  $(R_3 + R_4) / R_4$  times  $V_{out}/V_x$ .

We face a difficulty with this test. The voltage at the point  $V_x$  has an amplitude of  $V_{x,pp} = V_{out,pp} * [(R_4 + R_3)/(R_4)] / A_{open-loop}$ . If we make the voltage divider ratio  $R_4/(R_3 + R_4)$  very small, this makes  $V_{x,pp}$  larger and therefore easier to measure on an oscilloscope. Unfortunately, the DC output voltage of the circuit is also given by  $V_{os}(R_3 + R_4)/R_4$ , where  $V_{os}$  is the DC offset error of your op-amp. Given input MOSFET mismatch,  $V_{os}$  might be as large as  $\sim \pm 500$  mV, and the resulting DC output voltage  $V_{os}(R_3 + R_4)/R_4$  will then saturate the op-amp.

To fix this problem,

a) choose  $R_4=1$  KOhm,  $R_3=10$  kOhm.

This will result in  $V_{x,pp} = V_{out,pp} * 10 / A_{open-loop}$ , hence  $V_{x,pp} = V_{out,pp} / 5000$  for an open-loop gain of 50,000. This will make it difficult to measure differential gains larger than about 10,000. We will have to accept this limitation in measurement.

b) Please adjust the DC level at the output of the signal generator in order to produce a DC output voltage of zero volts during the above measurement

### Third test

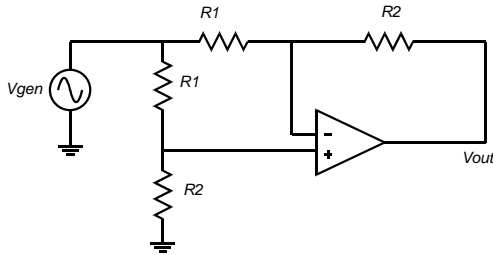

How to measure the CMRR of high-gain amplifiers

If the resistors are well-matched (take the time to find resistors accurate to 1% or better before testing), then the circuit gain will be about  $2 * (R_2 / R_1) * A_{cm} / A_D$

This circuit faces the same problem with DC offset voltage as earlier tests. To avoid serious problems with DC offset voltage, set  $R_1=1\text{ k}\Omega$ ,  $R_2=5\text{ k}\Omega$ . That will result in a DC output voltage about 6 times  $V_{os}$ .

### Reducing $V_{os}$

a) Using the curve tracer, compare your  $V_{th}$  of your input MOSFETs. Find 2 devices which are well-matched.

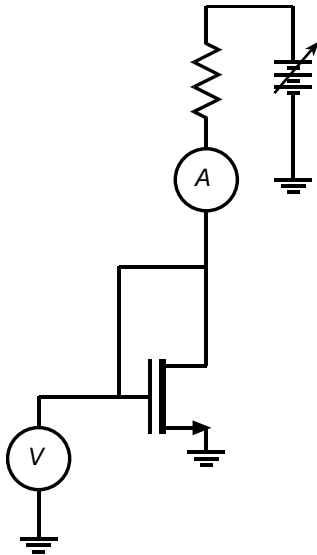

If you are having trouble with the curve tracer, try this setup. Perhaps  $1\text{ k}\Omega$  is appropriate for the resistor; it will depend upon the current you seek.

Set up the circuit to the left on a proto-board.

Adjust the supply voltage to obtain the current reading you desire on the ammeter; this current should be equal to the current you plan to use in your circuit. The voltmeter then measures the required  $V_{gs}$  to obtain this.

Select a pair of MOSFETs with  $V_{gs}$  matched as closely as possible.

It should be simple to re-adapt this test circuit for P-channel MOSFETs

