

ECE ECE145A (undergrad) and ECE218A (graduate)

Mid-Term Exam. November 9, 2021

Do not open exam until instructed to.

Open notes, open books, etc.

You have 1 hour and 15 minutes.

Use any and all reasonable approximations (5% accuracy is fine.), ***AFTER STATING THEM.***

Problem	Points Received	Points Possible
1		15
2a		10
2b		7
2c		8
2d (218 only)		10 (218A only)
3a		5
3b		7.5
3c (218 only)		5 (218A only)
3d		7.5
4		15
5a		5
5b (218 only)		10
5c		10 (218A only)
6		10
total		100 (145), 125 (218A)

Name: _____

Problem 1, 15 points

The Smith Chart and Frequency-Dependent Impedances.

HINT: use the scales on the figures to measure distances as needed.

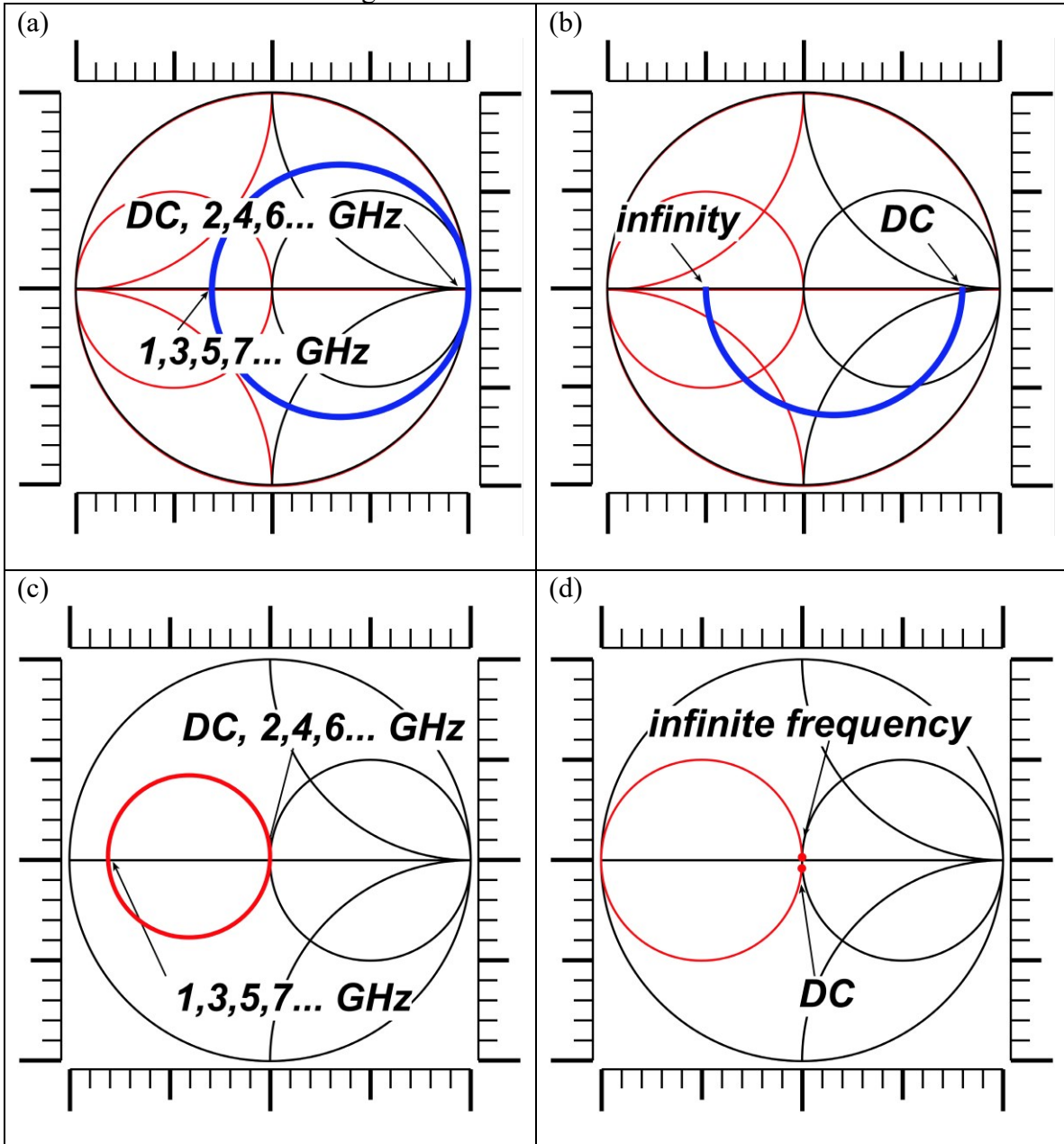

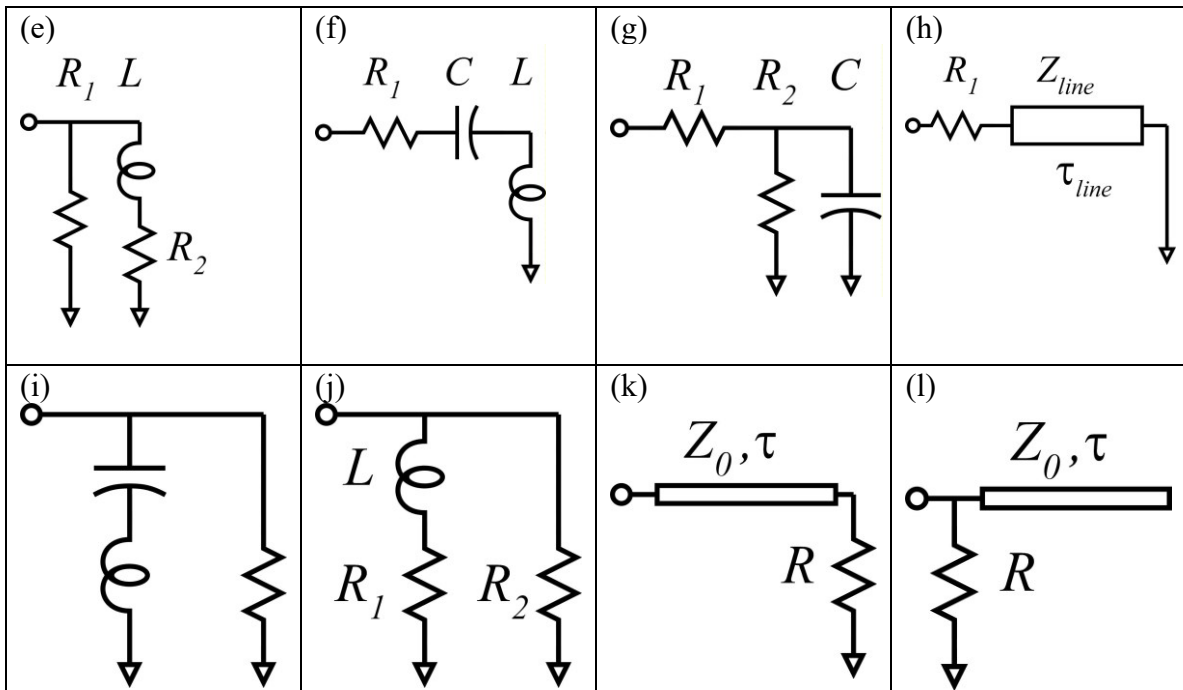

First match each Smith Chart with each circuit. ***Then determine as many component values as is possible*** (RLC values, transmission line delays and characteristic impedances)...note that some values cannot be determined with the information given. The charts all use 50 Ohm normalization:

Smith chart (a). Circuit=_____.
Component values: _____, _____, _____,

Smith chart (b). Circuit=_____.
Component values: _____, _____, _____,

Smith chart (c). Circuit=_____.
Component values: _____, _____, _____,

Smith chart (d). Circuit=_____.
Component values: _____, _____, _____,

Problem 2, 25 points (ece145A), 35 points (ece218A)
2-port parameters and Transistor models

Part a, 10 points

For the network at the right, give the numerical values of S_{21} and S_{11} . The reference Z_0 is 50 Ohms. The signal frequency is 1GHz, $R=50\text{Ohms}$, and $C=3.18\text{pF}$.

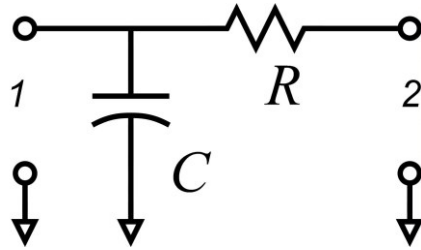

Part b, 7 points

Compute the four Y parameters for this network

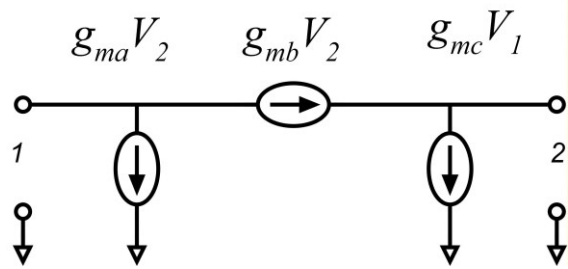

Part c, 8 points

Network "A" has

$$Z_A = \begin{bmatrix} Z_{11,A} & Z_{12,A} \\ Z_{21,A} & Z_{22,A} \end{bmatrix}$$

Compute the Z parameters for network "B"

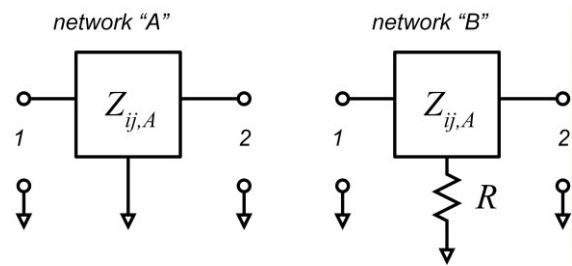

Part d, *ECE218A students only* 10 points

Network "A" has

$$Y_A = \begin{bmatrix} Y_{11,A} & Y_{12,A} \\ Y_{21,A} & Y_{22,A} \end{bmatrix}$$

Compute the Y parameters for network "B"

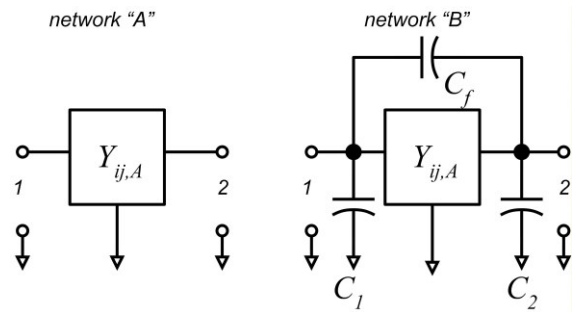

Problem 3, 20 points (ECE145A), 25 points (ECE 218A)

Available source power relationships, lumped/distributed relationships.

Part a, 5 points

V_s is 2V RMS at 1GHz

R_s is 5 Ohms, C is 1.59 pF.

At 2GHz, what is the available signal power? Draw the circuit diagram of a load network, with element values specified, that would, when connected to the source, absorb this amount of power from the generator

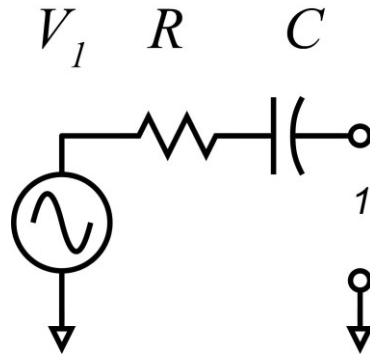

Part b, 7.5 points

In the network to the right, $R_{gen}=R_L=10$ Million Ohms, the transmission, line has a 50 Ohm characteristics impedance, a length of 1 meter, and a velocity of $2 \cdot 10^8$ meters/second.

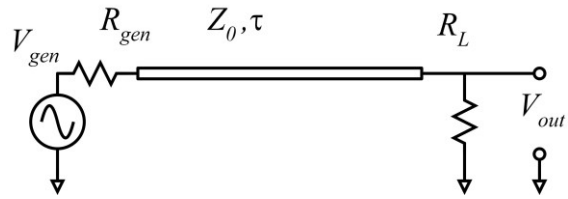

As frequency is increased from a few Hz into the MHz range, the magnitude of V_{out}/V_{gen} is observed to decrease.

Approximately at what frequency is V_{out}/V_{gen} at -3dB relative to its DC value?

Part c, 5 points (218A only)

In the network to the right, $R_{gen}=R_L=10$ Million Ohms, the transmission, line has a 50 Ohm characteristics impedance, a length of 1 meter, and a velocity of $2 \cdot 10^8$ meters/second.

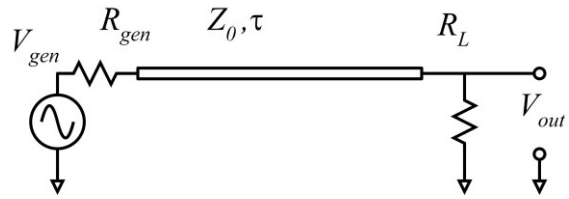

If the frequency is further increased, V_{out} will again increase. At what frequencies will V_{out}/V_{gen} be a maximum, and what value will V_{out}/V_{gen} then be ?

Part d, 7.5 points

In the network to the right, $R_{gen}=R_L=0.1$ Ohms, the transmission, line has a 50 Ohm characteristics impedance, a length of 1 meter, and a velocity of $2 \cdot 10^8$ meters/second.

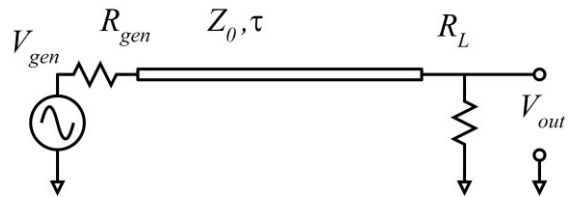

As frequency is increased from a few Hz into the MHz range, the magnitude of V_{out}/V_{gen} is observed to decrease.

Approximately at what frequency is V_{out}/V_{gen} at -3dB relative to its DC value?

Problem 4, 15 points

Impedance-matching exercise.

At 1GHz signal frequency, an antenna has an input impedance of $10+j0$ Ohms. Design a matching network, using a series inductor and a shunt capacitor, which matches this impedance to 50 Ohms.

Give all element values. Either use a separate impedance-admittance chart , or use the attached one below..

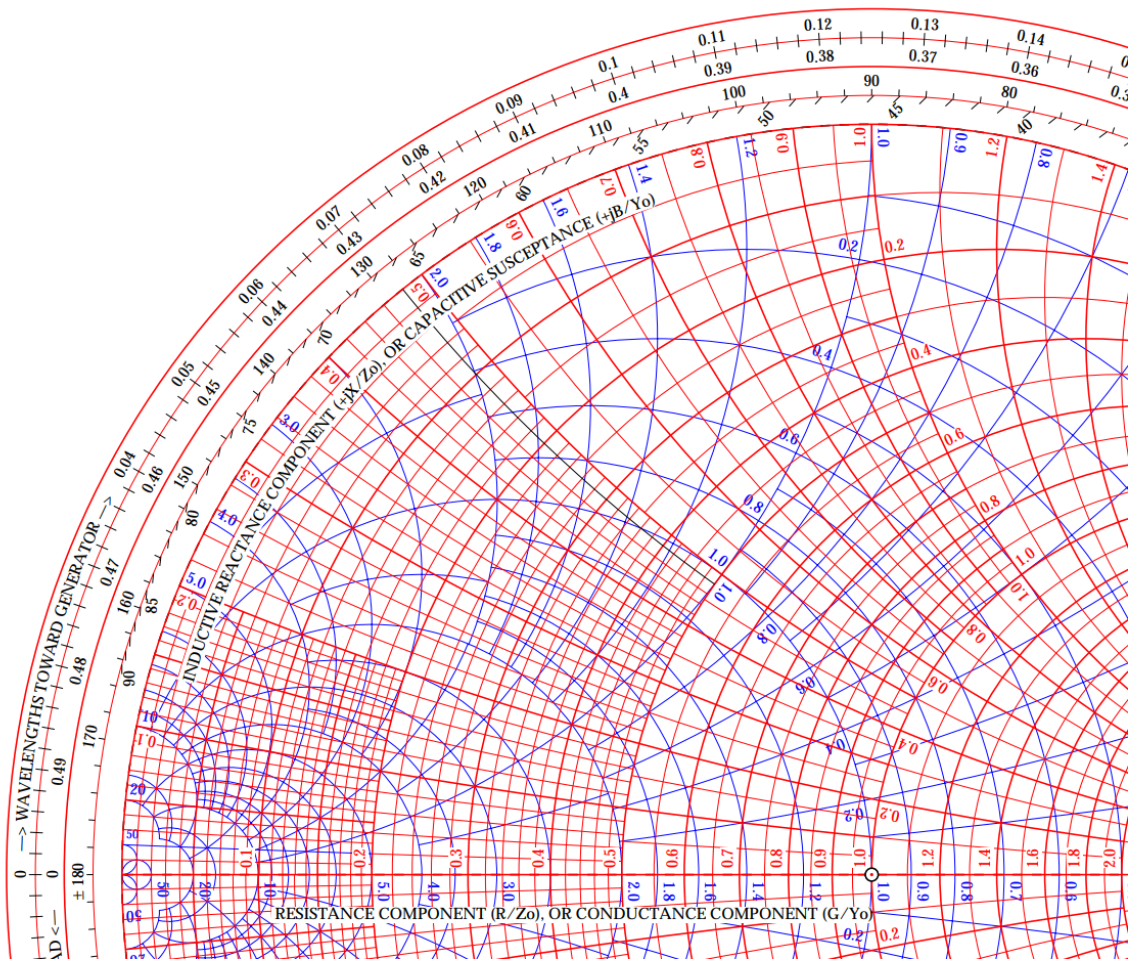

Problem 5, 15 points (ece145A), 25 points (218A)

Transmission-line properties.

Part a, 5 points

Stripline is like microstrip, except that it has a dielectric layer, and a ground above the signal conductor as well as below it.

If T is small, The characteristic impedance is, very approximately

$$Z_0 = (\mu_0 / \epsilon_r \epsilon_0)^{1/2} H / (4H + 2W)$$

where $(\mu_0 / \epsilon_0) = 377\Omega$, and ϵ_r is the insulator dielectric constant.

The velocity is $v = c / \epsilon_r^{1/2}$, where c is the speed of light.

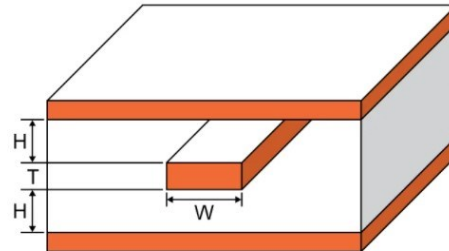

Suppose that the dielectric is Isola Astra, a commercial high-frequency printed circuit board material which has $\epsilon_r = 3.00$, and that H is 75 micrometers.

For 50 Ohms characteristic impedance, what must be the conductor width W ? What is the wave velocity on the transmission line?

If the conductor is 1 cm long, what is the total line capacitance and inductance?

Part b, 10 points (ece218A only)

Stripline is used with rows of closely-spaced vias between the top and bottom ground planes. These not only keep the two ground planes at the same potential, but also keep the stripline field confined to the region enclosed by the vias; the signal cannot radiate into the surrounding dielectric. Can you (1) estimate maximum allowable values of dielectric thickness H for a given signal frequency, and the maximum lateral distance W between vias ? (Assume S is so small as to be able to treat the row of vias as a continuous metal conductor.)

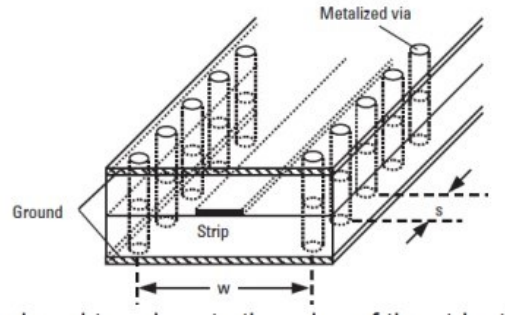

Part c, 10 points

Let us now estimate skin-effect losses, including for simplicity only skin loss on the signal conductor, not the ground plane. In stripline, the current flows equally on both the top and bottom of the signal conductor, with skin depth $\delta = \sqrt{2 / \omega \mu \sigma}$, equal to 0.2 micrometers in gold at 100GHz. The conductivity of Gold is 4.11×10^7 S/m. At 100GHz, how much loss would the line have, in dB, if 1cm long ?

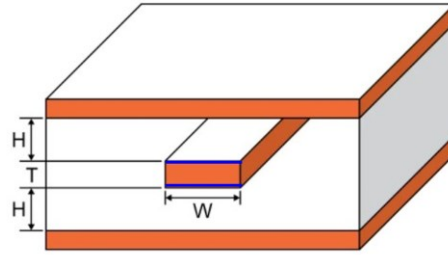

Problem 6, 10 points

Transmission lines in the time domain.

V_{gen} is a 1V step-function occurring at $t=0$ seconds. Z_{line} is 50 Ohms. τ_{line} is 1 ns.

R_L is $(50/9)$ Ohms

R_{gen} is 0 Ohms.

Plot $V_{out}(t)$ on the graph below.

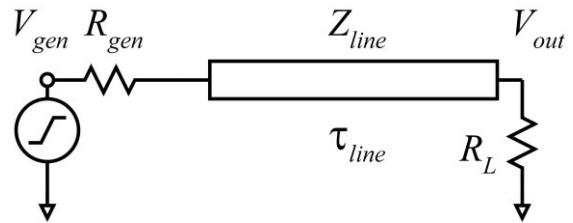

Does the step response of the line appear inductive, capacitive, both, or neither ?

