

Note: Homework #7 will be assigned on 11/19 but will not be due until Friday, 11/30.

Reading: Thomas and Rosa, Chap 6.

Problems from the textbook: 6-3, 6-6, 6-9, 6-24, 6-30, 6-31, 6-32, 6-36

1. The current in a 50 μH inductor is known to be $i_L = 18t e^{-10t}$ A for $t \geq 0$
 - a. Find the voltage across the inductor for $t > 0$.
 - b. Find the power (in microwatts) at the terminals of the inductor at $t = 200$ ms.
 - c. Is the inductor absorbing or delivering power at 200 ms?
 - d. Find the energy (in microjoules) stored in the inductor at 200 ms.
 - e. Find the maximum energy (in microjoules) stored in the inductor at the time (in microseconds) when it occurs.

2. The circuit below is driven with voltage $v_S(t)$ as shown in the plot. Derive equations for $v_O(t)$ and the total stored energy in the inductor, $w_L(t)$. Sketch $v_O(t)$ and $w_L(t)$.

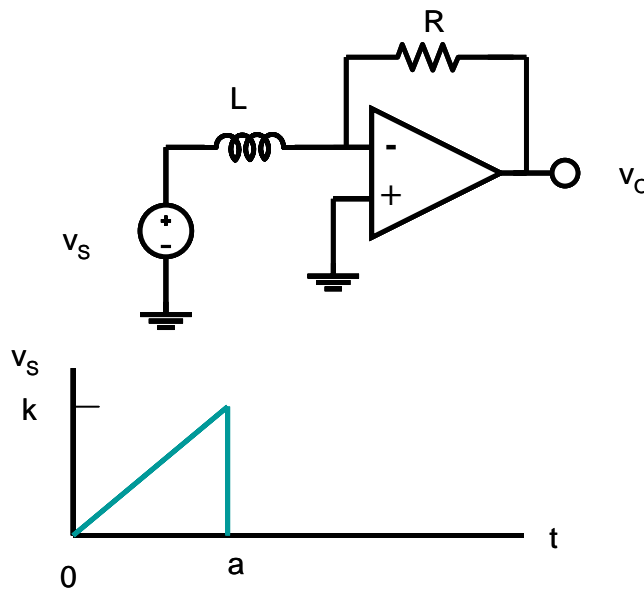

3. The three capacitors in the figure below are connected across the terminals of a black box at $t = 0$. The resulting current i_0 for $t > 0$ is known to be $i_0 = 1.92 e^{-20t}$ mA. If $v_0(0) = -5V$ and $v_1(0) = 25V$, find the following for $t \geq 0$:
- $v_2(t)$
 - $v_0(t)$
 - $v_1(t)$
 - $i_1(t)$, and
 - $i_2(t)$.

