Simple Op-Amp Circuits

OBJECTIVES:

To gain experience with design and construction of op-amp IC circuits, explore simple amplifier concepts and algebraic functional circuits, and further develop skills with the oscilloscope.

BACKGROUND:

Refer to the class text, or any text on electronics, for basic information on the operational amplifier and descriptions of the standard inverting and non-inverting amplifier configurations. Although most op-amp circuits can be understood based on the characteristics of an ideal op-amp, in the lab we will use real op amps with non-ideal characteristics. In this experiment we will encounter two of these: output saturation and finite slew rate. Output saturation simply means the op amp cannot force the output voltage beyond the voltage range it is supplied with. We will be supplying the op amp with +/- 15V. As you will find, the op-amp will not be able to swing above +15V or below -15V.

An additional non-ideality that can often show up with amplifier circuits is unwanted oscillation. This can result when the voltage supply on the breadboard is not sufficiently stable. Bypass capacitors, as shown in figure 2 (the yellow components) will be used to provide a ready source of charge right at the pins of the op amp. Since neither capacitors nor oscillators are the intended focus of this experiment, no additional explanation will be given here.

Note: In the circuits below the pin numbers for the various op amp connections are shown. Pins not shown are to be left unconnected.

PROCEDURE:

Part 1. Op-Amp Circuit Construction; Unity-gain buffer amplifier

The op-amp circuits are the only type of *active* circuit that we will encounter in ECE 2A. Active circuits require an external source of energy to operate properly. Figure 1 below shows a picture of the LM741 op-amp that we will use, with the pin numbers conventionally labeled (for more detail, a copy of the LM741 data sheet is posted at the class web site). Most op-amps have the same pin configuration. Use the +/-20V outputs of your bench power supply, adjusted appropriately, for the +/- 15V sources.

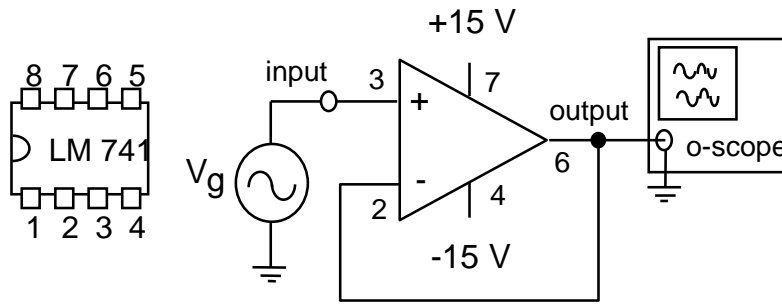

Fig 1: Op-amp IC pin diagram and test-circuit schematic

(1) Using your breadboards and the lab bench power supply, construct the circuit shown in figure 1 above. This is called the *voltage follower* configuration, and is a type of *buffer* amplifier. It is often used because the high input impedance prevents excessive loading of the source generator; i.e., no current is drawn from the source, therefore no voltage drops on any internal resistance of the source.

Figure 2 indicates how this circuit could be laid out on your breadboard. Also remember that we want the common terminal (COM) of the power supply to be at ground potential. It will be useful if you pick a row of sockets to be used for all ground connections. Cut and strip short jumper wires to make connections between strips on the board. Keep these flat against the board. Also, cut the capacitor leads if needed to keep the component close to the surface. Refer to the breadboard information in lab 1 if you are not sure how the board is constructed.

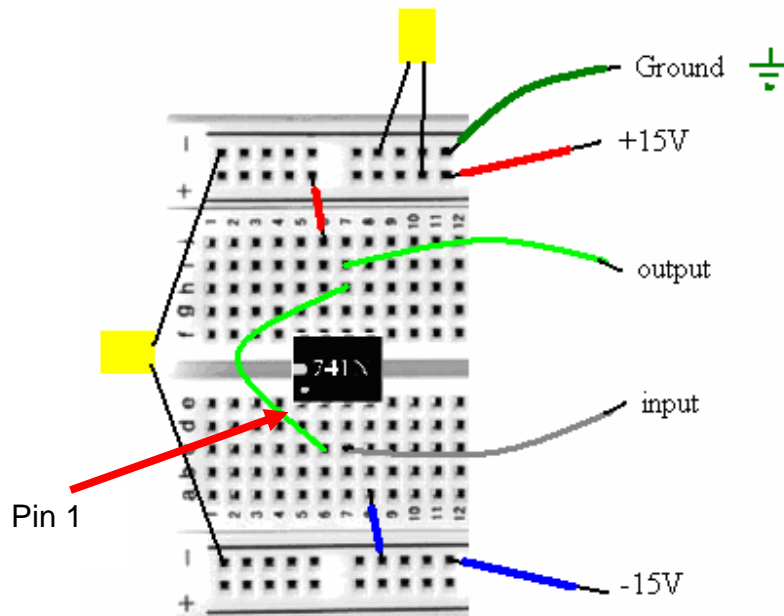
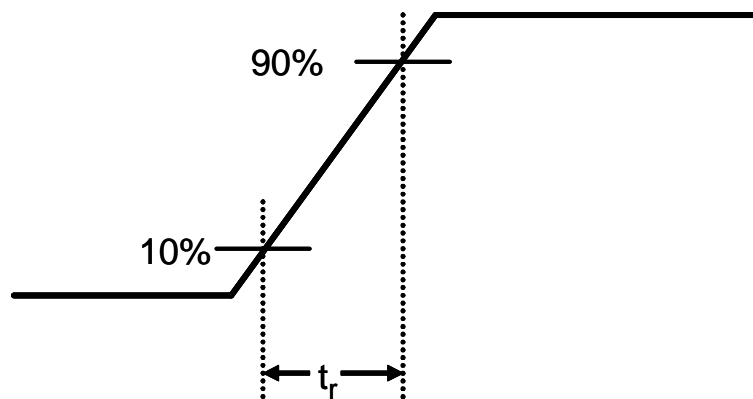

Fig. 2 Breadboard layout of fig 1

(2) Use the function generator at the bench as source V_g to provide a 1V amplitude (2V pk-pk), 1kHz sinewave excitation to the circuit, and observe the output on the

oscilloscope. Set up the scope so that the input signal is displayed on channel 1, and the output signal is displayed on channel 2. Make a plot of the two waveforms in your lab notebook. What is the voltage gain of this circuit? Is it an inverting or non-inverting amplifier?

(3) Adjust the input signal amplitude and frequency. The output should follow the input signal precisely for most input signals. However, in reality the output signal does not respond instantaneously to the input signal. This non-ideality can be observed when the input signal is a rapidly varying function of time. Set the function generator to a square wave signal and increase the frequency until you see a departure from ideal behavior. This could be, for example, if the output starts looking more like a trapezoid than a square wave. You will probably need to adjust the time scale (Sec/Div) to see this. At approximately what frequency does this occur? Make a plot of the output waveforms at a frequency above this point, and measure its rise time. Also note the peak-to-peak voltage of the output signal.



Risetime t_r is defined as the time required for a signal to transition from 10% to 90% of its final value.

(4) Continuing to use the square wave input, lower the frequency back to 1kHz, but leave the time scale and triggering as you had it for the measurement of step 3. Is the rise time of the op-amp still the same? Now adjust the time scale to where you can see several periods of the waveform. You should learn from this that the output rise time is limited, regardless of frequency, but it is less noticeable at lower frequencies.

Part 2. Inverting Amplifier

(1) Assemble the inverting amplifier circuit shown in figure 3. Remember to shut off the +/-15 V supply before assembling a new circuit. Cut and bend the resistor leads as needed to keep them flat against the board surface or form them over the IC package.

Note that there are additional connections to ground in this circuit. Use short wires to connect input and output to the generator and oscilloscope alligator clip leads.

(2) Apply a 1 Volt amplitude, 1kHz sine wave at the input (V_g), and display both input and output on the oscilloscope. Measure the voltage gain of this circuit, and compare to the theory discussed in class. Make a plot of the input/output waveforms in your notebook.

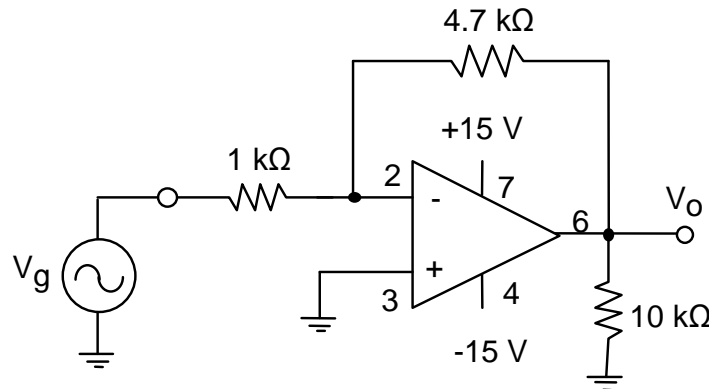

Fig 3: Inverting amplifier schematic

(3) Change the feedback resistor from 4.7k Ω to 10k Ω . What is the gain now? Slowly increase the amplitude of the input signal to 2 Volts. What happens? Describe and draw waveforms in your notebook. Can you explain this behavior?

Part 3. Summing Circuit

(1) With the power off, modify your inverting amplifier circuit as shown in figure 4. Use the +18V output of the power supply for V_{dc} . Turn the +18V output all the way down, so that you can adjust up from zero. This circuit behaves like an inverting amplifier with two inputs. What is the ideal relationship between the output voltage and the inputs V_g and V_{dc} ?

(2) Apply a 1 Volt amplitude sinewave for V_g and 2 Volt DC source for V_{dc} . Observe and record the input/output waveforms on the oscilloscope screen. Pay close attention to the ground signal level of the output channel on the oscilloscope screen (note: make sure both channels are set for DC coupling). When used in this way, such a circuit could be called a *level shifter*.

(3) Pull out the DC offset knob of the function generator and adjust the DC offset until V_o has zero DC component. Confirm this either by measuring V_o with a DC voltmeter, or by verifying on the oscilloscope that V_o swings equally above and below ground. What must the DC offset of the function generator be? Can you confirm this with a measurement?

(4) Push the DC offset knob back in to reset the offset to zero. With channel 2 of the scope (the channel connected to the op-amp output) set for 5V/div, turn up V_{dc} slowly to +18V. What happens to V_o ? Record the DC voltage of the output.

(5) Return V_{dc} to approximately +2V. Set the scope to 1V/div, AC coupled, and adjusted so you can see the complete V_o waveform. Turn V_{dc} back up to 18V. What does the oscilloscope trace for V_o look like? Does the amplifier appear to be amplifying?

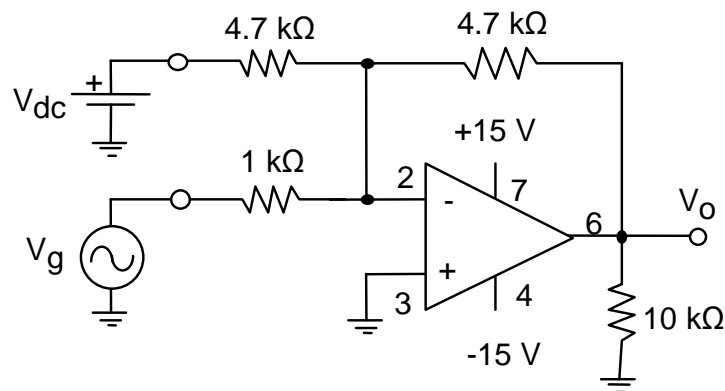

Fig 4: Op-amp summing circuit

(Extra Credit) Now raise your right hand and say the following out loud:

I solemnly promise I will never tell the TA my amplifier isn't amplifying without first using DC coupling to verify that the output is not saturated.

Part 4. Non-inverting amplifier

(1) Assemble the non-inverting amplifier circuit shown in figure 5. Remember to shut off the +/-15 V supply before assembling a new circuit. Use the decade resistor box for the feedback resistor (the 1k resistor between pins 6 and 2).

(2) Apply a 1 Volt amplitude, 1kHz sine wave at the input, and display both input and output on the oscilloscope. Measure the voltage gain of this circuit, and compare to the theory discussed in class. Make a plot of the input/output waveforms in your notebook.

(3) Increase the feedback resistance from 1kΩ to 9kΩ . What is the gain now?

(4) Increase the feedback resistance further until the onset of clipping, that is, until the peaks of the output signal begin to be flattened due to output saturation. Record the value of resistance where this happens. Increase the feedback resistance to 999kΩ.

Describe and draw waveforms in your notebook. What is the theoretical gain at this point? How small an input signal would be required to produce a 10V amplitude sine wave at the output, given this gain? Try to adjust the function generator to this value. You may need to use the 0.2V button on the function generator, which reduces the output amplitude. You will also need to lower the frequency from 1kHz to 100Hz. Describe the output achieved.

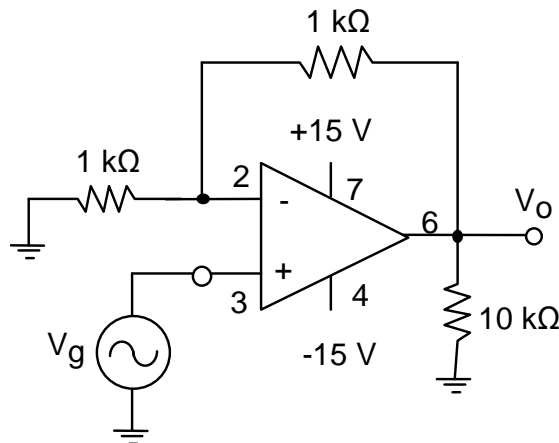

Fig 5: Non-inverting amplifier circuit

(5) Increase the amplitude of the function generator back to 1V and then disconnect the feedback resistor completely. The op-amp is now running "open-loop". Op amps used in this configuration are referred to as "voltage comparators". The output can assume one of only two states (voltage levels). These two state reflect a comparison of the input voltages. To see this, determine the voltage levels to write in each blank which make the following statement true for this circuit:

When $V_g > \underline{\hspace{2cm}}$, $V_o = \underline{\hspace{2cm}}$; when $V_g < \underline{\hspace{2cm}}$, $V_o = \underline{\hspace{2cm}}$.

In your report, present the results of your measurements in parts 1 - 4 and address the discussion questions below.

Discussion Questions

1. In part 1, step 3, you found the maximum rate the op-amp output could change. This is specified on the data sheet as the "slew rate", and has units of Volts/microsecond. Calculate the slew rate you observed from

$$\text{Slewrate} = \frac{\Delta V_{10-90}}{\text{rise_time}}$$

Is this greater than, equal to, or less than the typical value from the data sheet ?

2. The DC voltage you recorded in part 3, step 4, is the output saturation voltage. Is your measured value within the limits specified on the data sheet? The relevant spec in

the Fairchild data sheet is "Output Voltage Swing" $V_o(p-p)$, and our condition corresponds to $V_{cc} = \pm 15V$, $10k\Omega R_L$.

3. The \pm -voltage supplies, commonly labeled V_{cc} and V_{ee} , are also referred to as the power rails. Can you guess what the output voltage swing would be for an op-amp advertised as being a "rail to rail" op amp?