

ECE160

Multimedia

Lecture 9: Spring 2011

Image Compression Standards

The JPEG Standard

- JPEG is an image compression standard that was developed by the “Joint Photographic Experts Group”. JPEG was formally accepted as an international standard in 1992.
- JPEG is a **lossy** image compression method. It employs a **transform coding** method using the DCT (*Discrete Cosine Transform*).
- An image is a function of i and j (conventionally x and y) in the *spatial domain*.
- The 2D DCT is used as one step in JPEG in order to yield a frequency response which is a function $F(u, v)$ in the *spatial frequency domain*, indexed by two integers u and v .

Observations for JPEG Image Compression

- **Observation 1:** Useful image contents change relatively slowly across the image. It is unusual for intensity to vary widely several times in a small area, for example, within an 8x8 pixel block.
 - Much of the information in an image is repeated, hence “spatial redundancy”.
- **Observation 2:** Psychophysical experiments show that humans are less likely to notice the loss of high spatial frequency components than the loss of lower frequency components.
 - The spatial redundancy can be reduced by reducing the high spatial frequency contents.
- **Observation 3:** Visual acuity (accuracy in distinguishing closely spaced lines) is greater for gray (“black and white”) than for color.
 - chroma subsampling (4:2:0) is used in JPEG.

Main Steps in JPEG Image Compression

- Transform RGB to YIQ or YUV and subsample color.
- DCT on image blocks.
- Quantization.
- Zig-zag ordering and run-length encoding.
- Entropy coding.

Block diagram for JPEG encoder

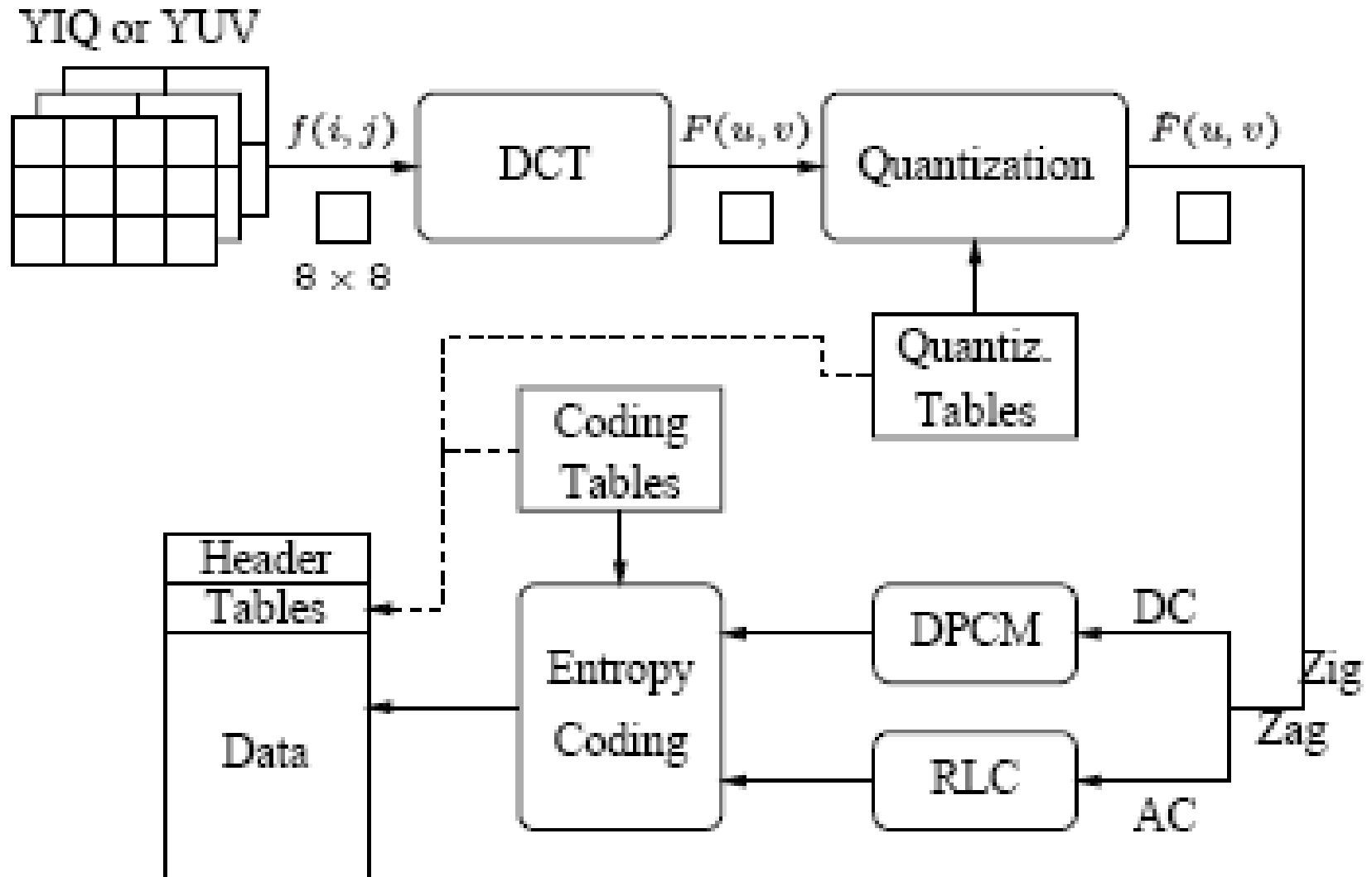

Block diagram for JPEG encoder

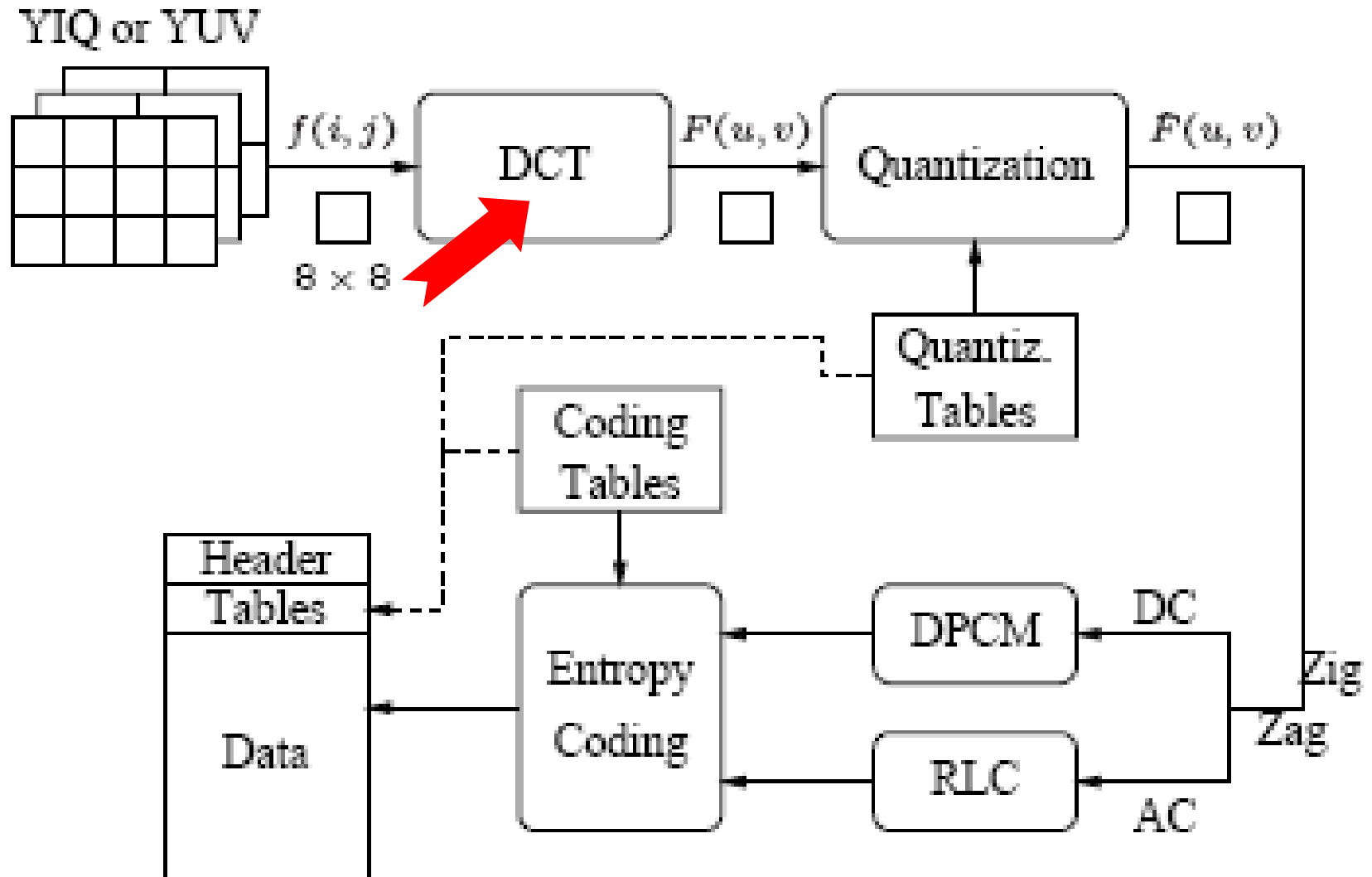

DCT on Image Blocks

- Each image is divided into 8 × 8 blocks. The 2D DCT is applied to each block image $f(i,j)$, with output being the DCT coefficients $F(u,v)$ for each block.
- Using blocks has the effect of isolating each block from its neighboring context. This is why JPEG images look choppy ("blocky") when a high *compression ratio* is specified by the user.

Block diagram for JPEG encoder

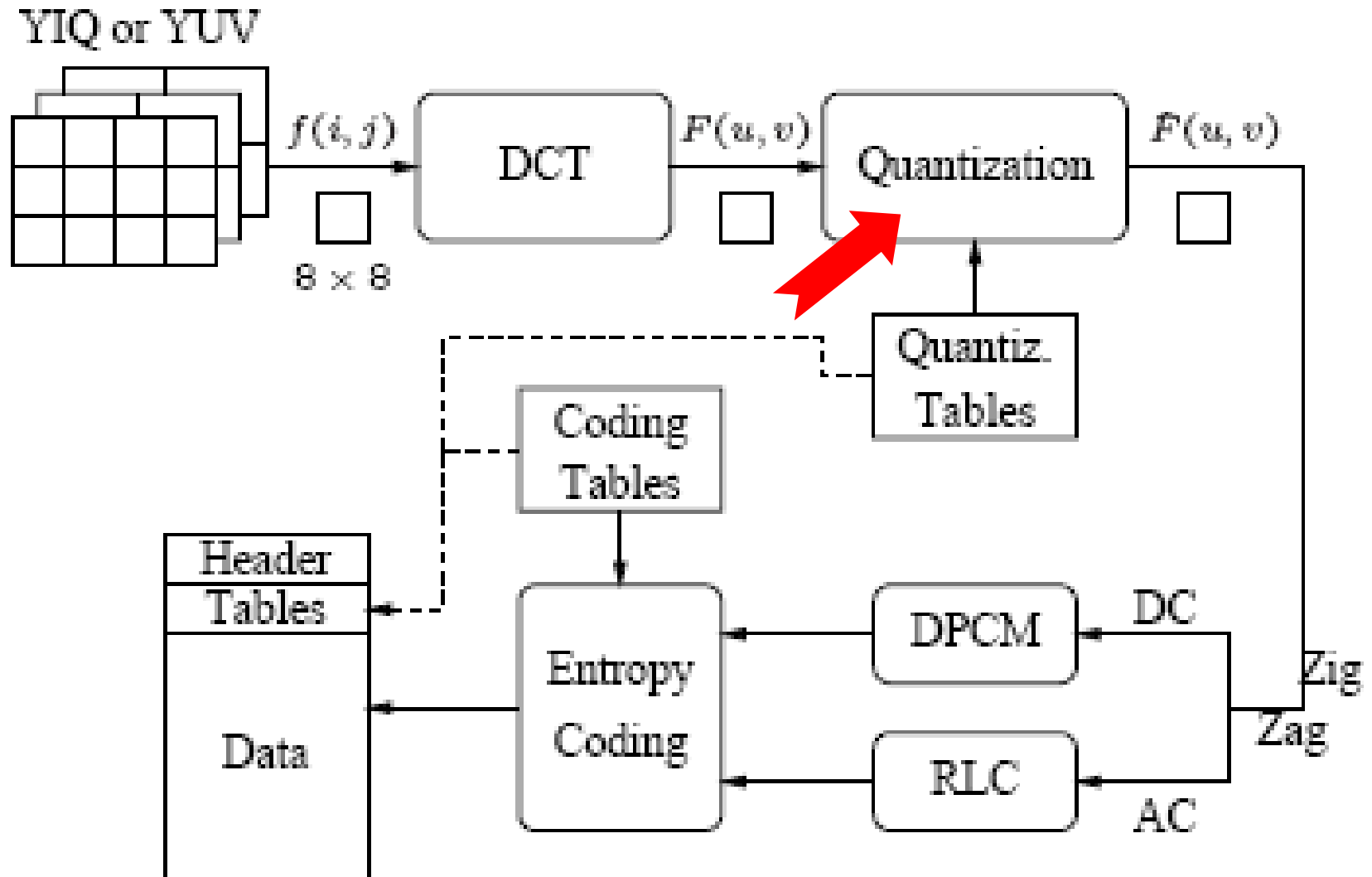

Quantization

$$\hat{F}(u, v) = \text{round} \left(\frac{F(u, v)}{Q(u, v)} \right)$$

- $F(u, v)$ represents a DCT coefficient, $Q(u, v)$ is a “quantization matrix” entry, and $\hat{F}(u, v)$ represents the *quantized DCT coefficients* which JPEG will use in the succeeding entropy coding.
 - **The quantization step is the main source for loss in JPEG compression.**
 - The entries of $Q(u, v)$ tend to have larger values towards the lower right corner. This introduces more loss at the higher spatial frequencies - a practice supported by Observations 1 and 2.
 - The Luminance Quantization Table and The Chrominance Quantization Table provide the default $Q(u, v)$ values obtained from psychophysical studies to maximize the compression ratio while minimizing perceptual losses in JPEG images.

Luminance Quantization Table

16	11	10	16	24	40	51	61
12	12	14	19	26	58	60	55
14	13	16	24	40	57	69	56
14	17	22	29	51	87	80	62
18	22	37	56	68	109	103	77
24	35	55	64	81	104	113	92
49	64	78	87	103	121	120	101
72	92	95	98	112	100	103	99

Chrominance Quantization Table

17	18	24	47	99	99	99	99
18	21	26	66	99	99	99	99
24	26	56	99	99	99	99	99
47	66	99	99	99	99	99	99
99	99	99	99	99	99	99	99
99	99	99	99	99	99	99	99
99	99	99	99	99	99	99	99
99	99	99	99	99	99	99	99

JPEG compression for a smooth image block



An 8x8 block from
the Y image of 'Lena'

```

200 202 189 188 189 175 175 175
200 203 198 188 189 182 178 175
203 200 200 195 200 187 185 175
200 200 200 200 197 187 187 187
200 205 200 200 195 188 187 175
200 200 200 200 200 190 187 175
205 200 199 200 191 187 187 175
210 200 200 200 188 185 187 186

```

$f(i, j)$

```

515 65 -12  4  1  2 -8  5
-16  3  2  0  0 -11 -2  3
-12  6 11 -1  3  0  1 -2
-8  3  -4  2 -2  -3 -5 -2
 0 -2  7 -5  4  0 -1 -4
 0 -3  -1  0  4  1 -1  0
 3 -2  -3  3  3  -1 -1  3
-2  5  -2  4 -2  2 -3  0

```

$F(u, v)$

JPEG compression for a smooth image block

```

32  6  -1  0  0  0  0  0
-1  0   0  0  0  0  0  0
-1  0   1  0  0  0  0  0
-1  0   0  0  0  0  0  0
  0  0   0  0  0  0  0  0
  0  0   0  0  0  0  0  0
  0  0   0  0  0  0  0  0
  0  0   0  0  0  0  0  0

```

$F(u, v)$

```

512 66 -10  0  0  0  0  0
-12  0   0  0  0  0  0  0
-14  0  16  0  0  0  0  0
-14  0   0  0  0  0  0  0
  0  0   0  0  0  0  0  0
  0  0   0  0  0  0  0  0
  0  0   0  0  0  0  0  0
  0  0   0  0  0  0  0  0

```

$F(u, v)$

```

199 196 191 186 182 178 177 176
201 199 196 192 188 183 180 178
203 203 202 200 195 189 183 180
202 203 204 203 198 191 183 179
200 201 202 201 196 189 182 177
200 200 199 197 192 186 181 177
204 202 199 195 190 186 183 181
207 204 200 194 190 187 185 184

```

$f(i, j)$

```

 1  6 -2  2  7 -3 -2 -1
-1  4  2 -4  1 -1 -2 -3
 0 -3 -2 -5  5 -2  2 -5
-2 -3 -4 -3 -1 -4  4  8
 0  4 -2 -1 -1 -1  5 -2
 0  0  1  3  8  4  6 -2
 1 -2  0  5  1  1  4 -6
 3 -4  0  6 -2 -2  2  2

```

$\epsilon(i, j) = f(i, j) - F(i, j)$

JPEG compression for a textured image block



Another 8x8 block from
the Y image of 'Lena'

```

70 70 100 70 87 87 150 187
85 100 96 79 87 154 87 113
100 85 116 79 70 87 86 196
136 69 87 200 79 71 117 96
161 70 87 200 103 71 96 113
161 123 147 133 113 113 85 161
146 147 175 100 103 103 163 187
156 146 189 70 113 161 163 197

```

$f(i, j)$

```

-80 -40 89 -73 44 32 53 -3
-135 -59 -26 6 14 -3 -13 -28
47 -76 66 -3 -108 -78 33 59
-2 10 -18 0 33 11 -21 1
-1 -9 -22 8 32 65 -36 -1
5 -20 28 -46 3 24 -30 24
6 -20 37 -28 12 -35 33 17
-5 -23 33 -30 17 -5 -4 20

```

$F(u, v)$

JPEG compression for a textured image block

```

-5 -4  9 -5  2  1  1  0
-11 -5 -2  0  1  0  0 -1
 3 -6  4  0 -3 -1  0  1
 0  1 -1  0  1  0  0  0
 0  0 -1  0  0  1  0  0
 0 -1  1 -1  0  0  0  0
 0  0  0  0  0  0  0  0
 0  0  0  0  0  0  0  0

```

$F(u, v)$

```

-80 -44 90 -80  48  40 51  0
-132 -60 -28  0  26  0  0 -55
 42 -78 64  0 -120 -57  0 56
 0 17 -22  0  51  0  0  0
 0  0 -37  0  0 109  0  0
 0 -35 55 -64  0  0  0  0
 0  0  0  0  0  0  0  0
 0  0  0  0  0  0  0  0

```

$F(u, v)$

```

 70  60 106  94  62 103 146 176
 85 101  85  75 102 127  93 144
 98  99  92 102  74  98  89 167
132  53 111 180  55  70 106 145
173  57 114 207 111  89  84  90
164 123 131 135 133  92  85 162
141 159 169  73 106 101 149 224
150 141 195  79 107 147 210 153

```

$f(i, j)$

```

 0 10  -6 -24  25 -16  4 11
 0 -1 11  4 -15 27  -6 -31
 2 -14 24 -23  -4 -11  -3 29
 4 16 -24 20 24  1 11 -49
-12 13 -27  -7  -8 -18 12 23
-3  0 16  -2 -20 21  0 -1
 5 -12  6 27  -3  2 14 -37
 6  5  -6  -9  6 14 -47 44

```

$\epsilon(i, j) = f(i, j) - \hat{f}(i, j)$

Block diagram for JPEG encoder

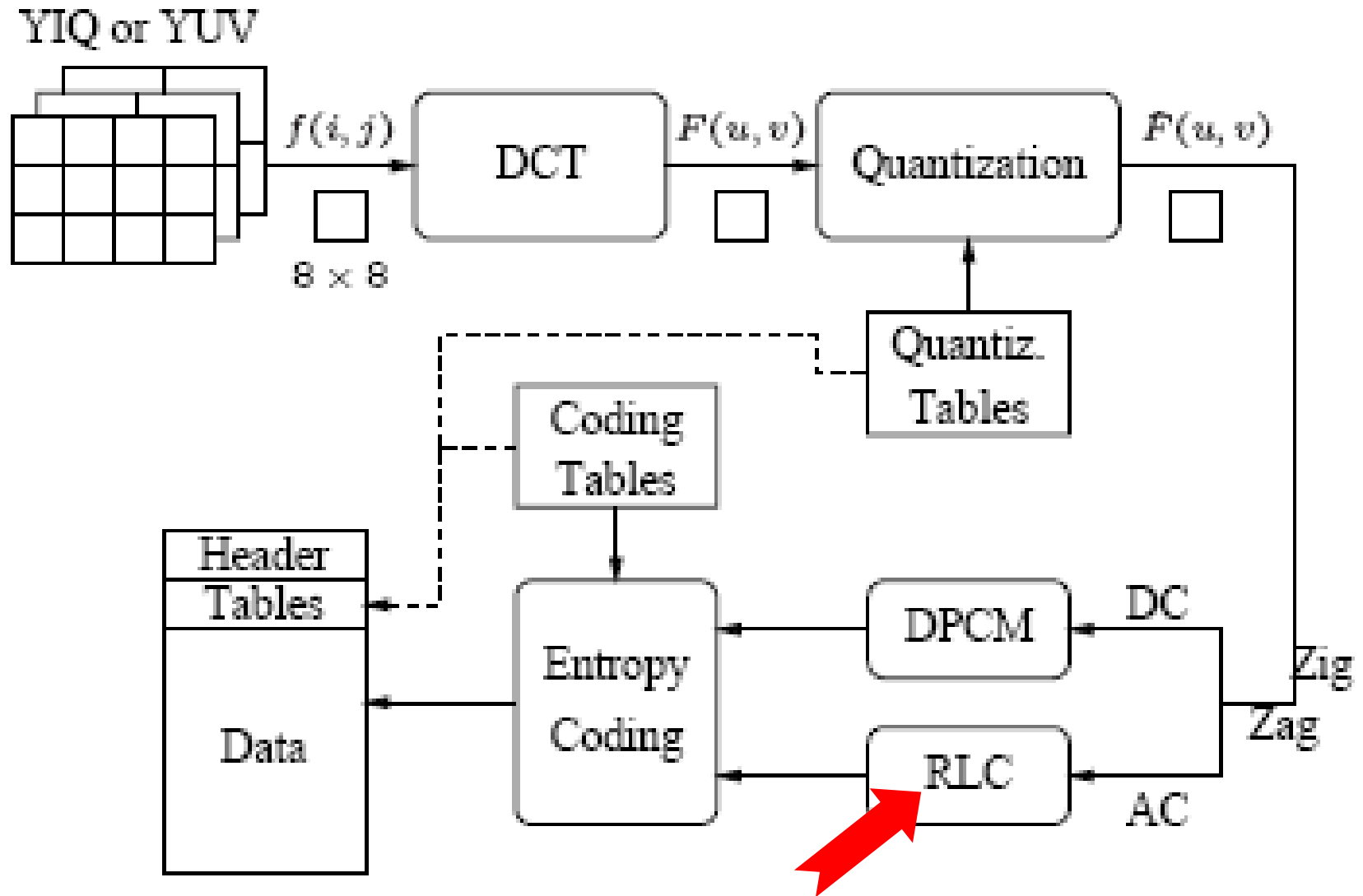

Run-length Coding (RLC) on AC coefficients

- RLC aims to turn the $\hat{F}(u,v)$ values into sets $\{\text{\#-zeros-to-skip}, \text{next non-zero value}\}$.
- To make a long run of zeros more likely, a *zig-zag scan* is used on the 8x8 matrix $\hat{F}(u,v)$

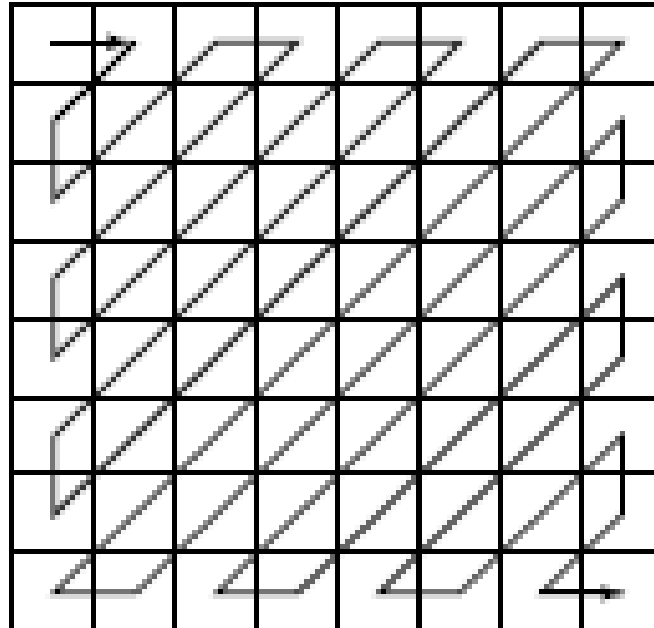

Block diagram for JPEG encoder

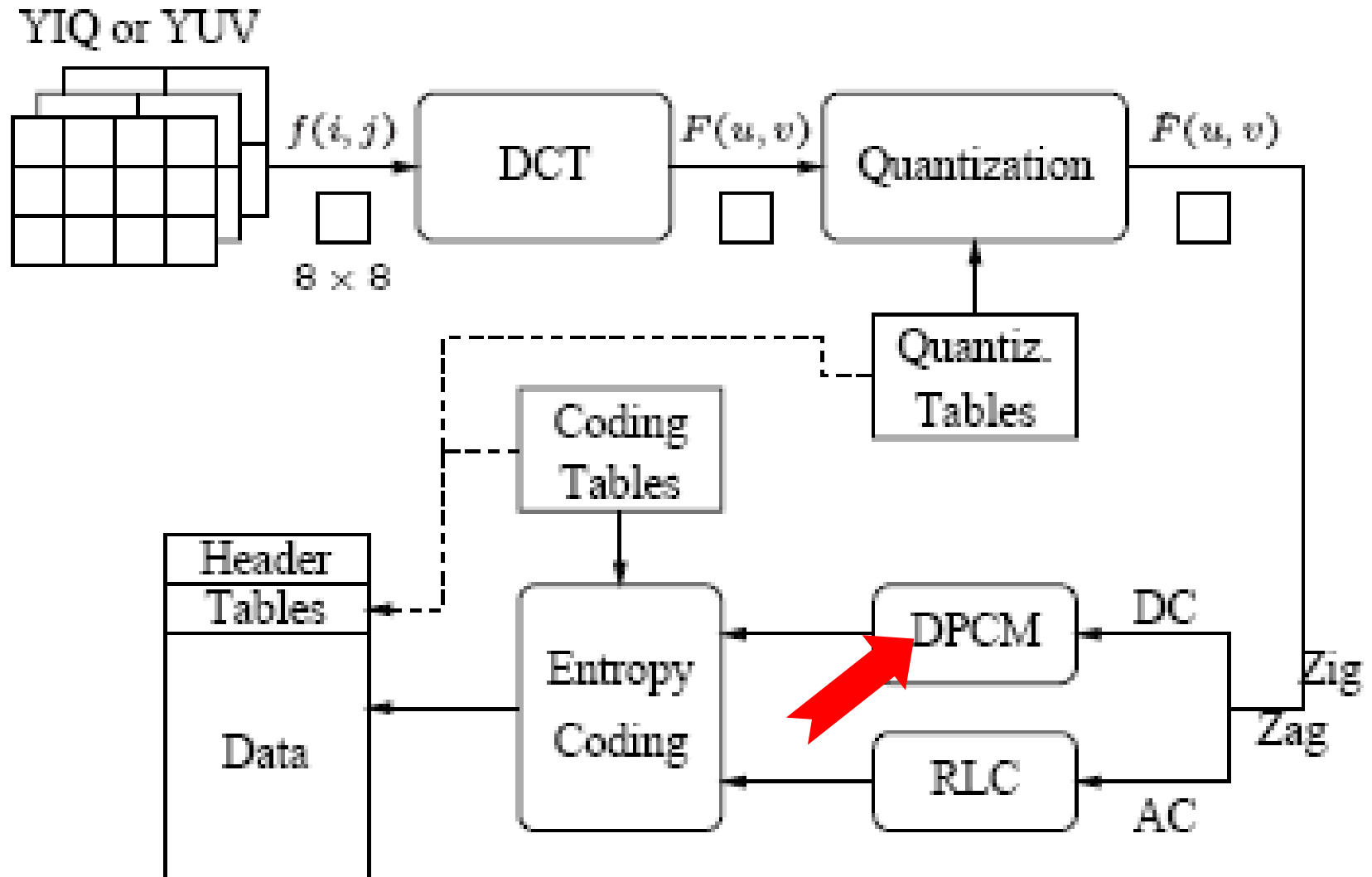

DPCM on DC coefficients

- The DC coefficients are coded separately from the AC ones.
- *Differential Pulse Code Modulation (DPCM)* is the coding method.
- If the DC coefficients for the first 5 image blocks are 150, 155, 149, 152, 144, then the DPCM would produce 150, 5, -6, 3, -8, assuming $d_j = DC_{j+1} - DC_j$, and $d_0 = DC_0$.

Block diagram for JPEG encoder

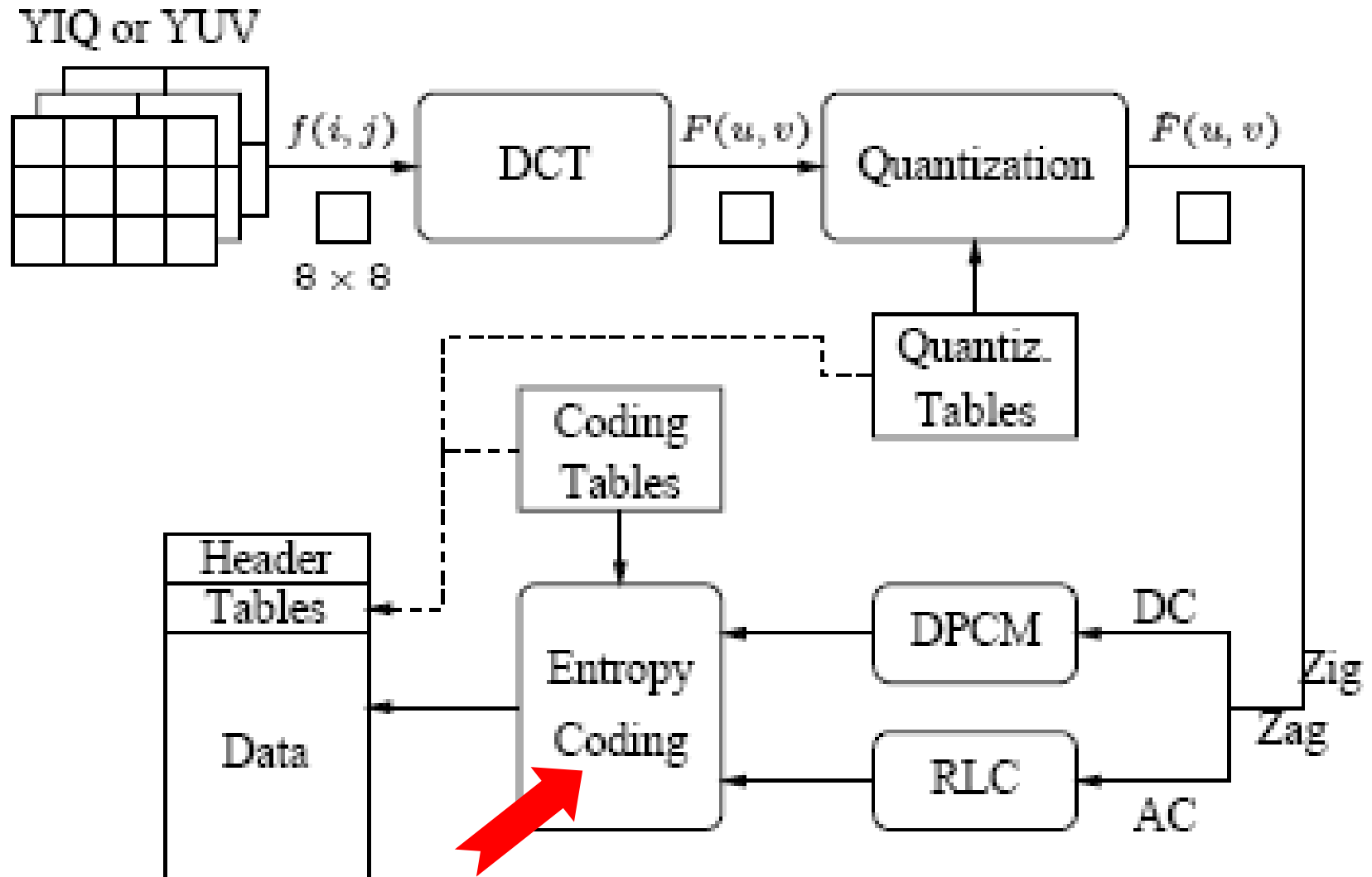

Entropy Coding

- The DC and AC coefficients finally undergo an entropy coding step to gain a possible further compression.
- Use DC as an example: each DPCM coded DC coefficient is represented by (SIZE, AMPLITUDE),
 - SIZE indicates how many bits are used to represent the coefficient,
 - AMPLITUDE contains the actual bits.
- In the example, codes 150, 5, -6, 3, -8 will become
 (8, 10010110), (3, 101), (3, 001), (2, 11), (4, 0111) .

- SIZE is Huffman coded since smaller SIZEs occur more often.
- AMPLITUDE is not Huffman coded, its value can change widely so Huffman coding has no benefit.

SIZE	AMPLITUDE
1	-1, 1
2	-3, -2, 2, 3
3	-7..-4, 4..7
4	-15..-8, 8..15
.	.
.	.
.	.
10	-1023..-512, 512..1023

Four Common JPEG Modes

- Sequential Mode - the default JPEG mode, implicitly assumed in the discussions so far. Each graylevel image or color image component is encoded in a single left-to-right, top-to-bottom scan.
- Progressive Mode.
- Hierarchical Mode.
- Lossless Mode - discussed in Chapter 7, to be replaced by JPEG-LS

Progressive Mode

- Progressive JPEG delivers low quality versions of the image quickly, followed by higher quality passes.
1. **Spectral selection:** Uses “spectral” (spatial frequency spectrum) characteristics of the DCT coefficients: higher AC components provide detail information.
 - Scan 1: Encode DC and first few AC components, e.g., AC1, AC2.
 - Scan 2: Encode a few more AC components, e.g., AC3, AC4, AC5.
 - ...
 - Scan k: Encode the last few ACs, e.g., AC61, AC62, AC63.

Progressive Mode

2. **Successive approximation:**

Instead of gradually encoding spectral bands, all DCT coefficients are encoded simultaneously but with their most significant bits (MSBs) first.

Scan 1: Encode the first few MSBs, e.g., Bits 7, 6, 5, 4.

Scan 2: Encode a few more less significant bits, e.g., Bit 3.

...

Scan m: Encode the least significant bit (LSB), Bit 0.

Hierarchical Mode

- The encoded image at the lowest resolution is basically a compressed low-pass filtered image, whereas the images at successively higher resolutions provide additional details (differences from the lower resolution images).
- Similar to Progressive JPEG, the Hierarchical JPEG images can be transmitted in multiple passes progressively improving quality.

Encoder and Decoder for Three-level Hierarchical JPEG

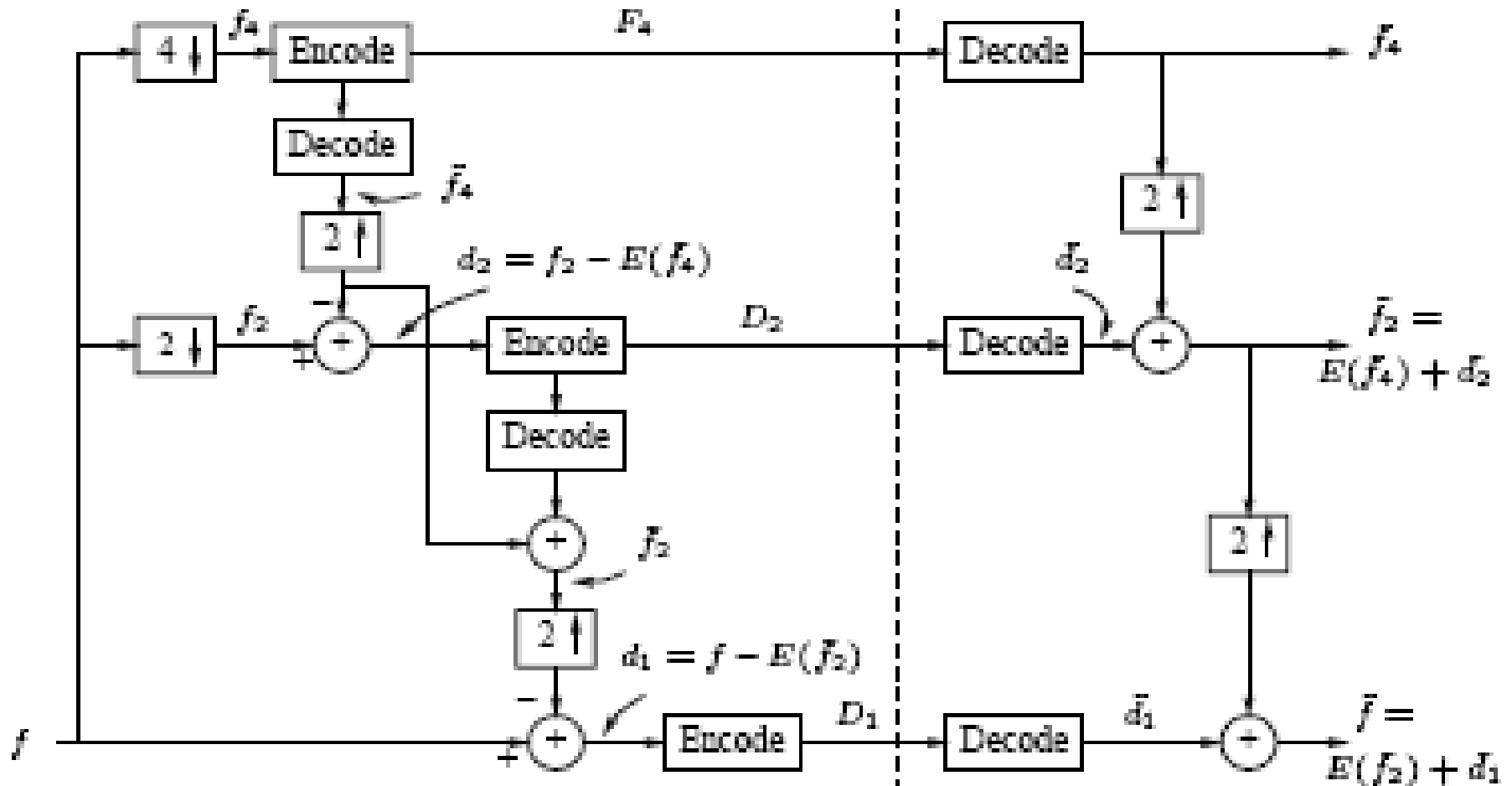

Encoder and Decoder for Three-level Hierarchical JPEG

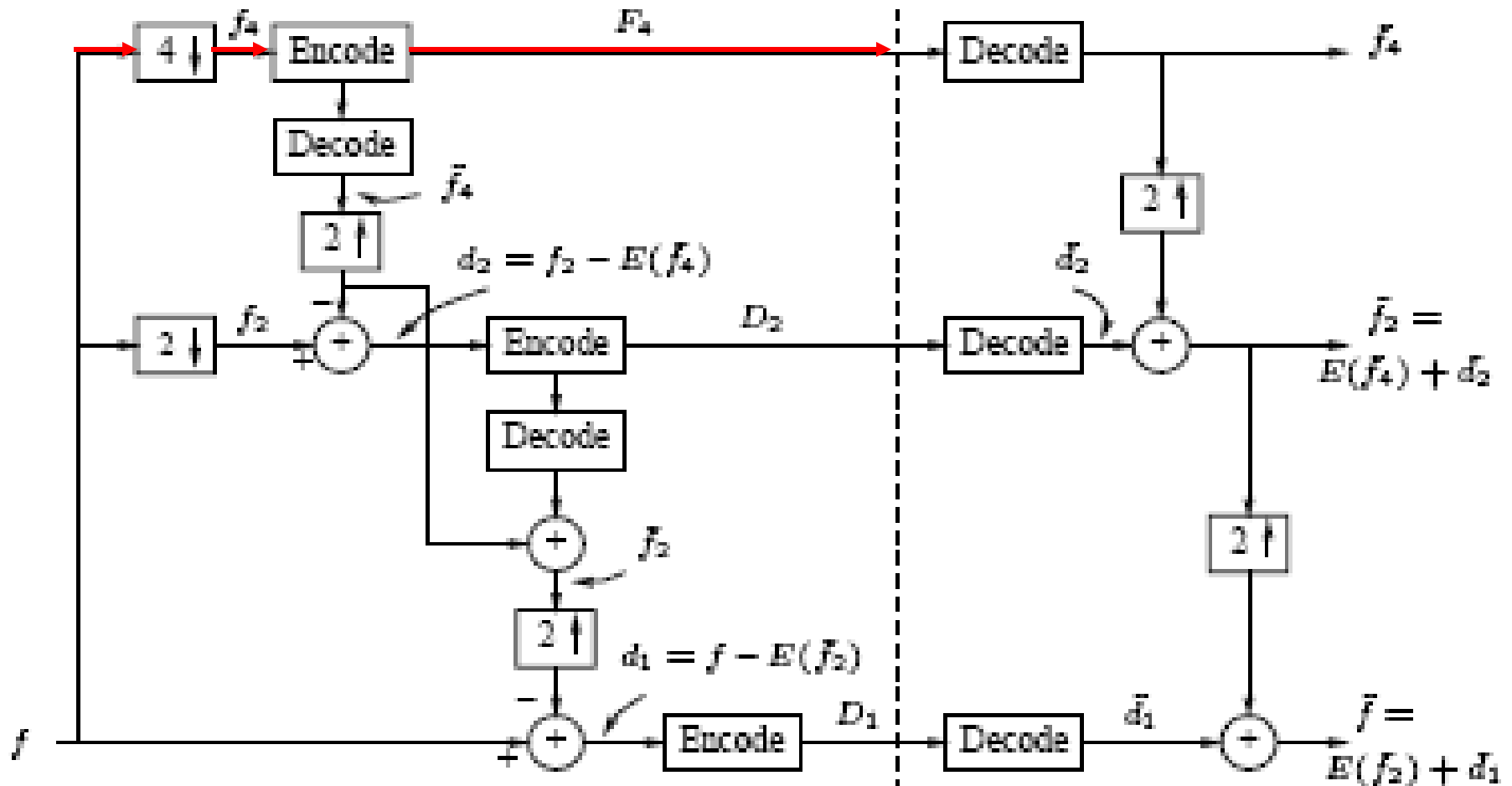

Encoder and Decoder for Three-level Hierarchical JPEG

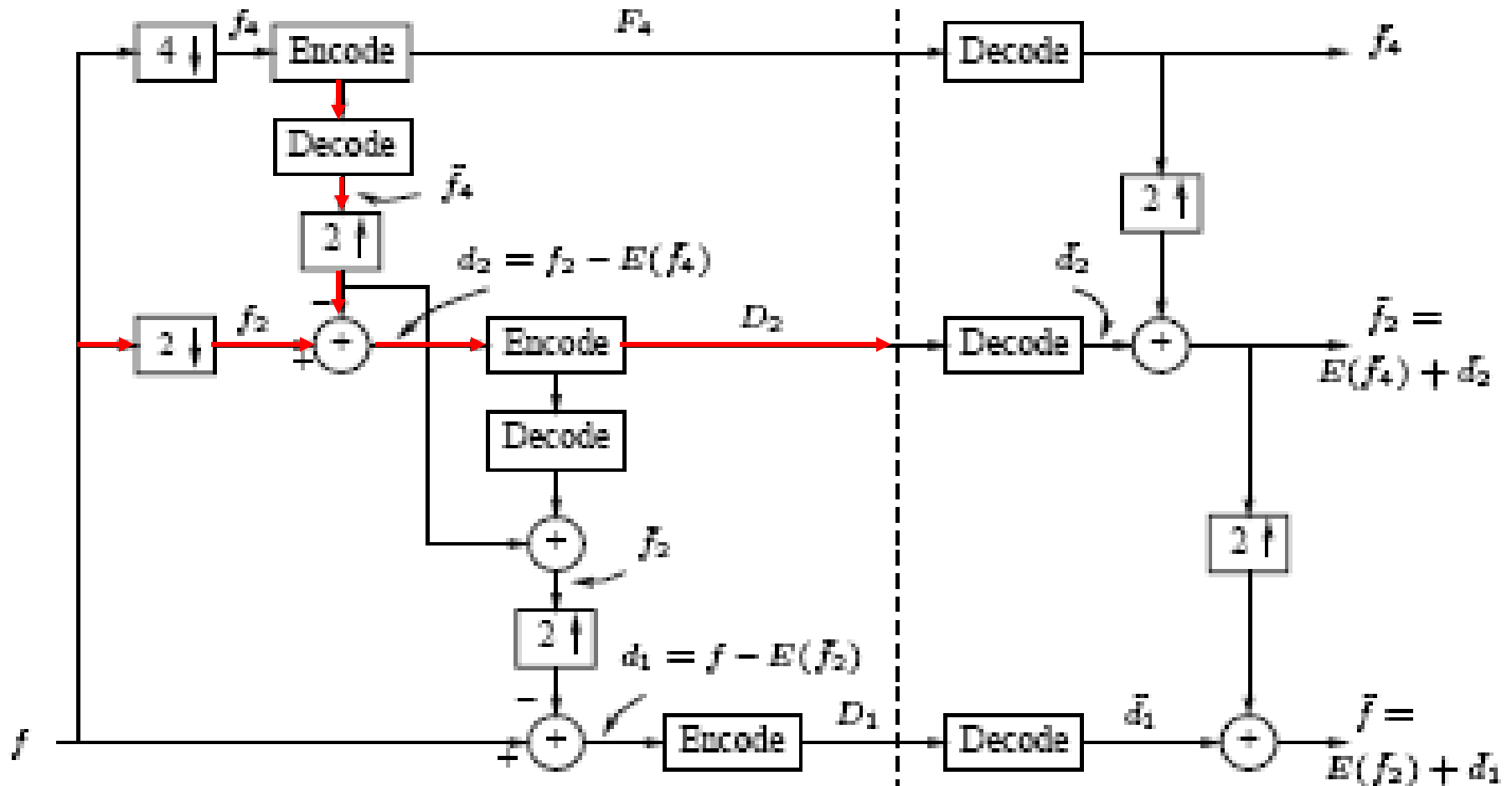

Encoder and Decoder for Three-level Hierarchical JPEG

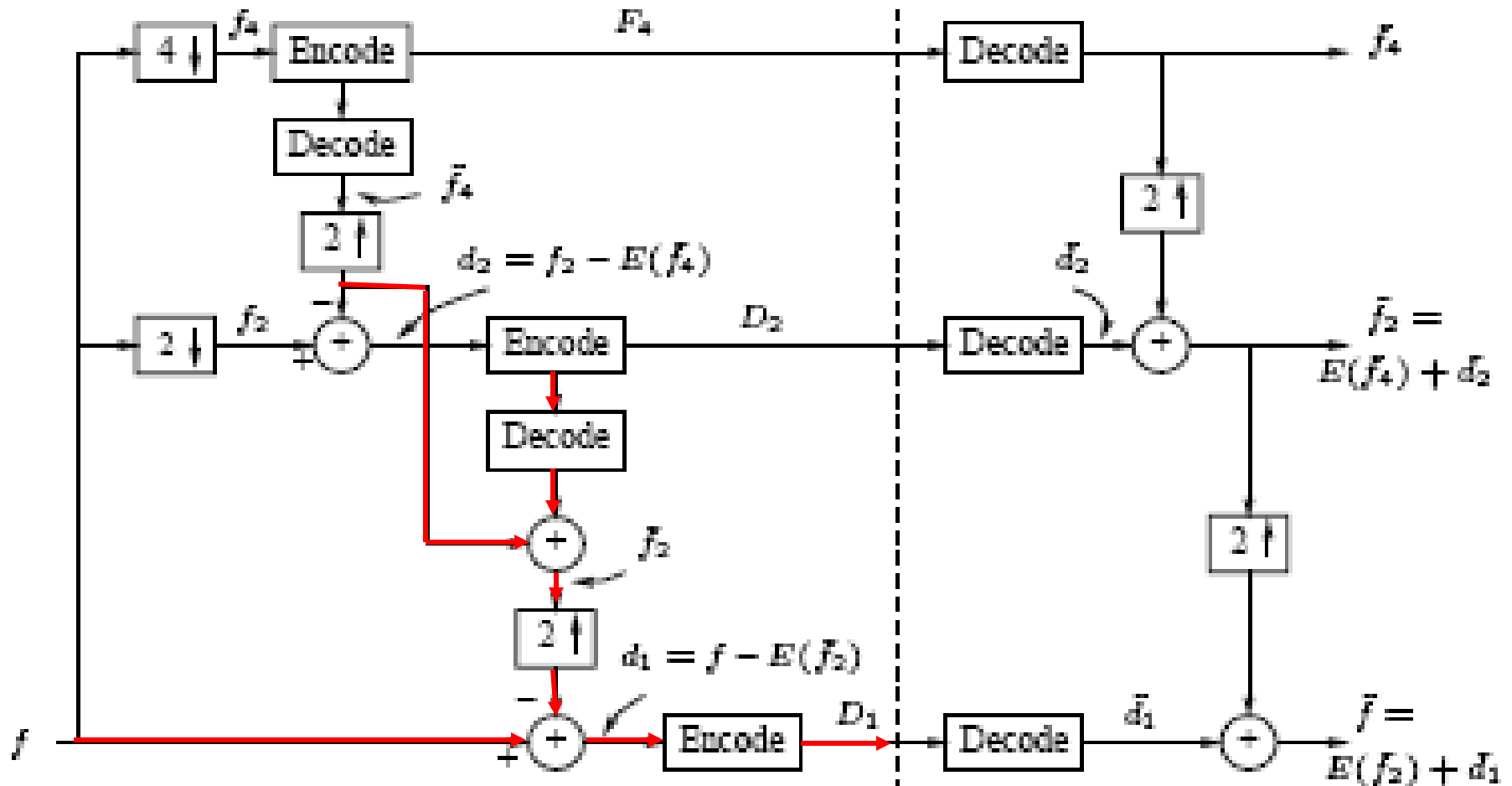

Encoder for Three-level Hierarchical JPEG

1. Reduction of image resolution: Reduce resolution of the input image f (e.g., 512x512) by a factor of 2 in each dimension to obtain f_2 (e.g., 256x256). Repeat this to obtain f_4 (e.g., 128x128).
2. Compress low-resolution image f_4 : Encode f_4 using any other JPEG method (e.g., Sequential, Progressive) to obtain F_4 .
3. Compress difference image d_2 :
 - (a) Decode F_4 to obtain \tilde{f}_4 . Use any interpolation method to expand \tilde{f}_4 to be of the same resolution as f_2 and call it $E(\tilde{f}_4)$.
 - (b) Encode difference $d_2 = f_2 - E(\tilde{f}_4)$ using any other JPEG method (e.g., Sequential, Progressive) to generate D_2 .
4. Compress difference image d_1 :
 - (a) Decode D_2 to obtain \tilde{d}_2 ; add it to $E(\tilde{f}_4)$ to get $\tilde{f}_2 = E(\tilde{f}_4) + \tilde{d}_2$ which is a version of f_2 after compression and decompression.
 - (b) Encode difference $d_1 = f - E(\tilde{f}_2)$ using any other JPEG method (e.g., Sequential, Progressive) to generate D_1 .

Decoder for Three-level Hierarchical JPEG

1. Decompress the encoded low-resolution image F_4 :
 - Decode F_4 using the same JPEG method as in the encoder to obtain \tilde{f}_4 .
2. Restore image \tilde{f}_2 at the intermediate resolution:
 - Use $E(\tilde{f}_4) + \tilde{d}_2$ to obtain \tilde{f}_2 .
3. Restore image \tilde{f} at the original resolution:
 - Use $E(\tilde{f}_2) + \tilde{d}_1$ to obtain \tilde{f} .

The JPEG Bitstream

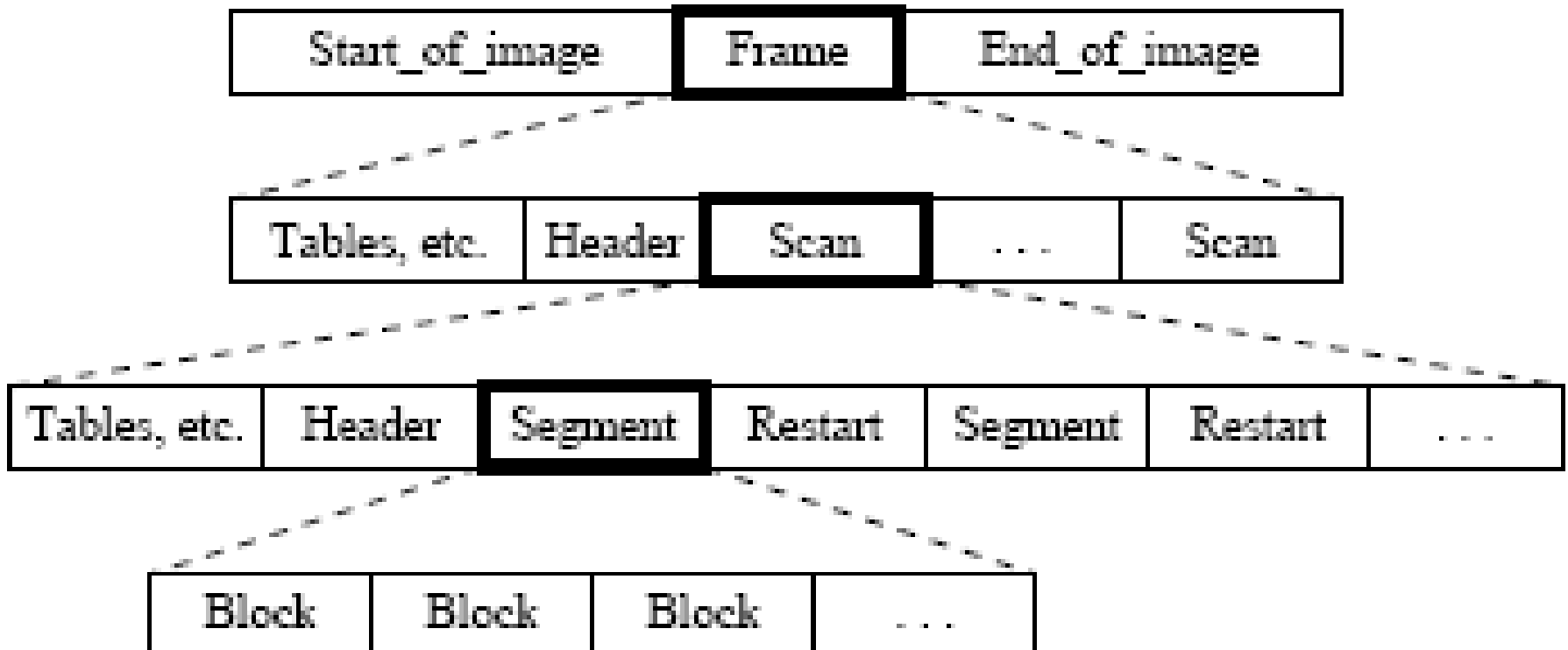

The JPEG2000 Standard

- Design Goals:
 - To provide a better rate-distortion tradeoff and improved subjective image quality.
 - To provide additional functionalities lacking in the current JPEG standard.
- The JPEG2000 standard addresses the following problems:
 - **Lossless and Lossy Compression:** There is currently no standard that can provide superior lossless compression and lossy compression in a single bitstream.

The JPEG2000 standard

- **Low Bit-rate Compression:** The current JPEG standard offers excellent rate-distortion performance in mid and high bit-rates. However, at bit-rates below 0.25 bpp, subjective distortion becomes unacceptable. This is important if we hope to receive images on our web-enabled ubiquitous devices, such as web-aware wristwatches and so on.
- **Large Images:** The new standard will allow image resolutions greater than 64K by 64K without tiling. It can handle image size up to $2^{32} - 1$.
- **Single Decompression Architecture:** The current JPEG standard has 44 modes, many of which are application specific and not used by the majority of JPEG decoders.

The JPEG2000 standard

- **Transmission in Noisy Environments:** The new standard will provide improved error resilience for transmission in noisy environments such as wireless networks and the Internet.
- **Progressive Transmission:** The new standard provides seamless quality and resolution scalability from low to high bit-rate. The target bit-rate and reconstruction resolution need not be known at the time of compression.
- **Region of Interest Coding:** The new standard allows the specification of Regions of Interest (ROI) which can be coded with superior quality than the rest of the image. One might like to code the face of a speaker with more quality than the surrounding furniture.

The JPEG2000 standard

- **Computer Generated Imagery:** The current JPEG standard is optimized for natural imagery and does not perform well on computer generated imagery.
- **Compound Documents:** The new standard offers metadata mechanisms for incorporating additional non-image data as part of the file. This might be useful for including text along with imagery, as one important example.
- In addition, JPEG2000 is able to handle up to 256 channels of information whereas the current JPEG standard is only able to handle three color channels.

Properties of JPEG2000 Image Compression

- Uses Embedded Block Coding with Optimized Truncation (EBCOT) algorithm which partitions each subband LL, LH, HL, HH produced by the **wavelet transform** into small blocks called “code blocks”.
- A separate scalable bitstream is generated for each code block => improved error resilience.



Main Steps of JPEG2000 Image Compression

- Embedded Block coding and bitstream generation.
 1. Bitplane coding.
 2. Fractional bitplane coding.
- Post compression rate distortion (PCRD) optimization.
- Layer formation and representation.

Layer Formation and Representation

- JPEG2000 offers both resolution and quality scalability through the use of a layered bitstream organization and a two-tiered coding strategy.
- The first tier produces the embedded block bitstreams while the second tier compresses block summary information.
- Quality layer Q_1 contains the initial $R_i^{n_i^1}$ bytes of each code block B_i and the other layers Q_q contain the incremental contribution $L_i^q = R_i^{n_i^q} - R_i^{n_i^{q-1}} \geq 0$ from code block B_i .

Layer Formation and Representation

- Three quality layers with eight blocks each.

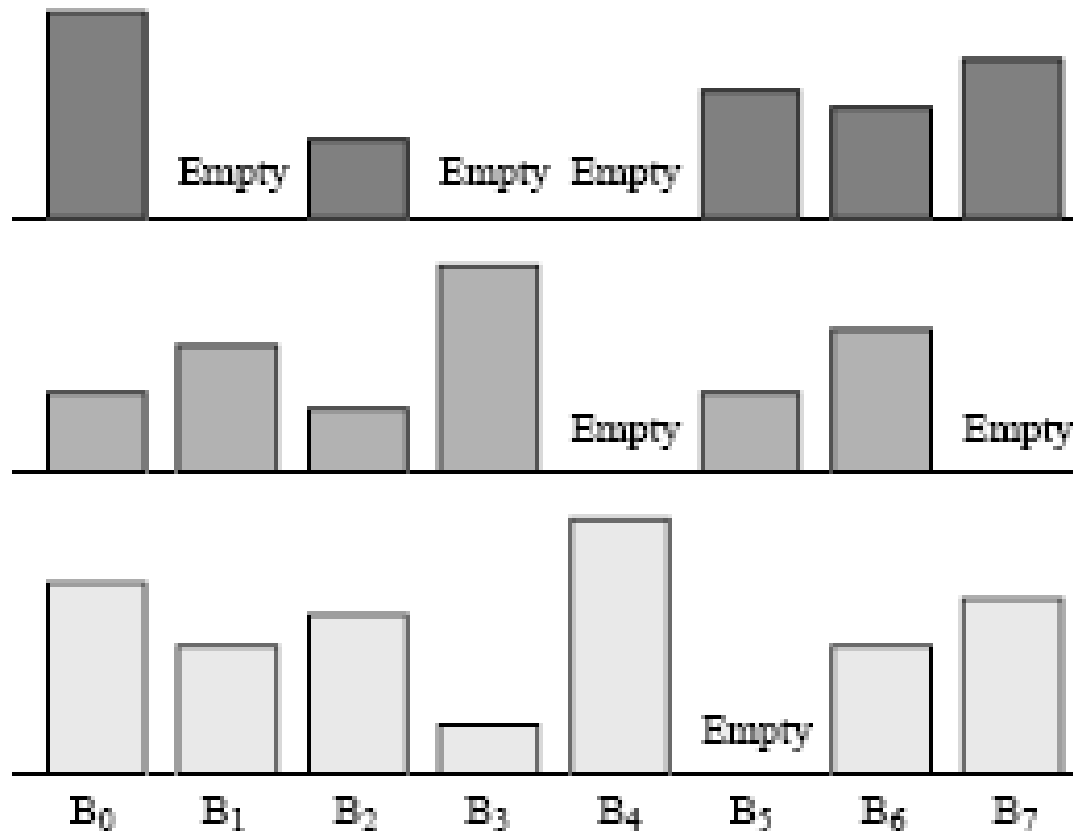

Region of Interest Coding

Goal: Particular regions of the image may contain important information, thus should be coded with better quality than others.

- Usually implemented using the MAXSHIFT method which scales up the coefficients within the ROI so that they are placed into higher bit-planes.
- During the embedded coding process, the resulting bits are placed in front of the non-ROI part of the image. Therefore, given a reduced bit-rate, the ROI will be decoded and refined before the rest of the image.

Region of Interest Coding

- Region of interest (ROI) coding of an image using a circularly shaped ROI. (a) 0.4 bpp, (b) 0.5 bpp, (c) 0.6bpp, and (d) 0.7 bpp



(a)



(b)



(c)



(d)

Performance comparison for JPEG and JPEG2000

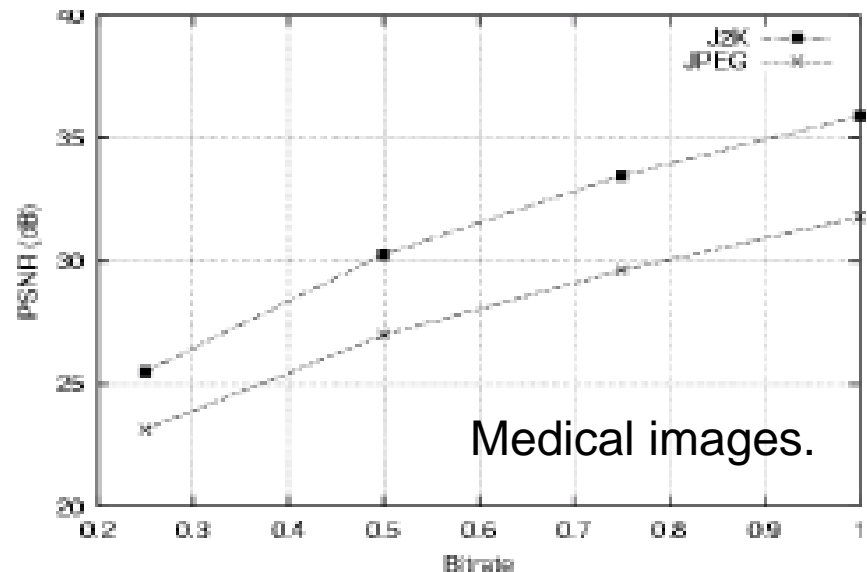
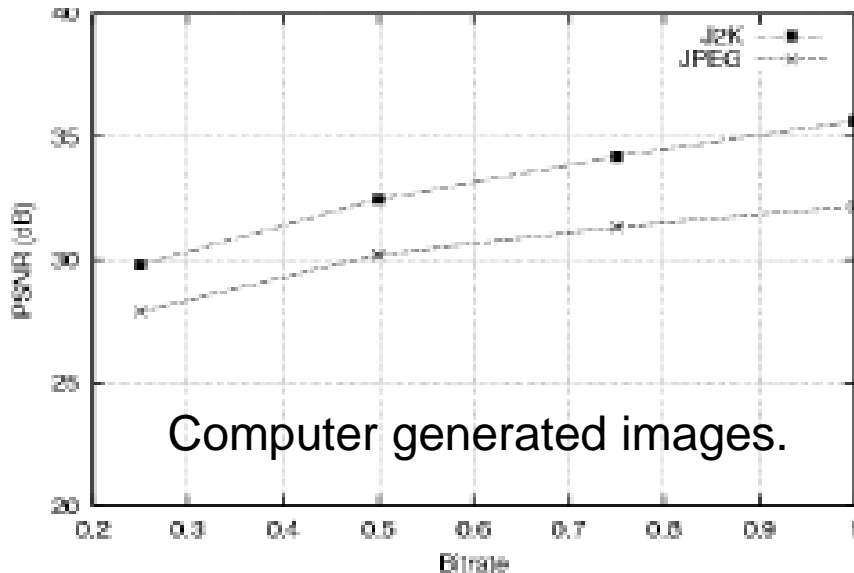
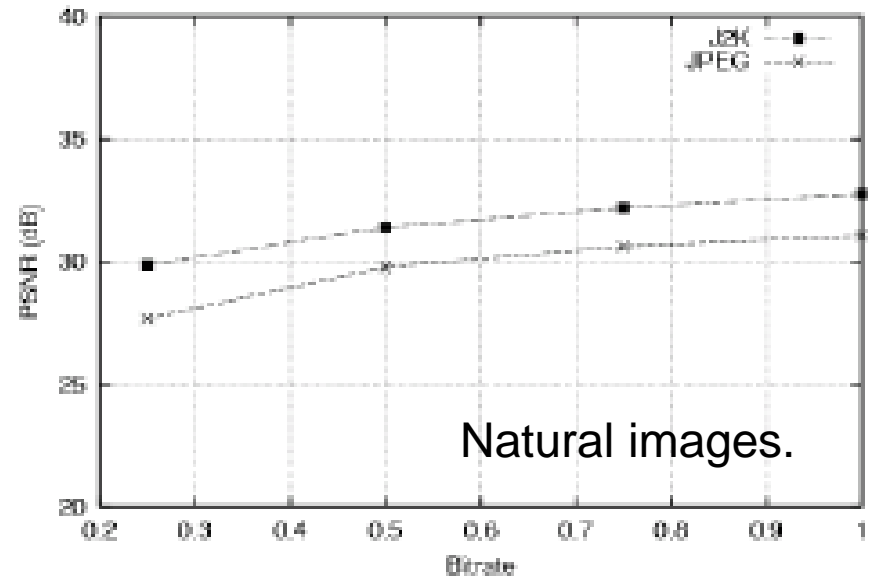

Comparison of JPEG and JPEG2000.

Original image.





(b)



(c)

- (b) JPEG(left) and JPEG2000(right) images compressed at 0.75 bpp.
- (c) JPEG and JPEG2000 images compressed at 0.25 bpp.

The JPEG-LS Standard

- JPEG-LS is in the current ISO/ITU standard for lossless or “near lossless” compression of continuous tone images.
- It is part of a larger ISO effort aimed at better compression of medical images.
- Uses the LOCO-I (LOW COMplexity LOSSless COMpression for Images) algorithm proposed by Hewlett-Packard.
- Motivated by the observation that complexity reduction is often more important than small increases in compression offered by more complex algorithms.

JBIG and JBIG-2: Bi-level Image Compression Standards

Main Goal: Enables the handing of documents in electronic form.

- Primarily used to code scanned images of printed or handwritten text, computer generated text, and facsimile transmissions.
- JBIG is a lossless compression standard. It also offers progressive encoding/decoding capability, the resulting bitstream contains a set of progressively higher resolution images.
- JBIG-2 introduces *model-based coding* - similar to context-based coding. It supports lossy compressions well.