

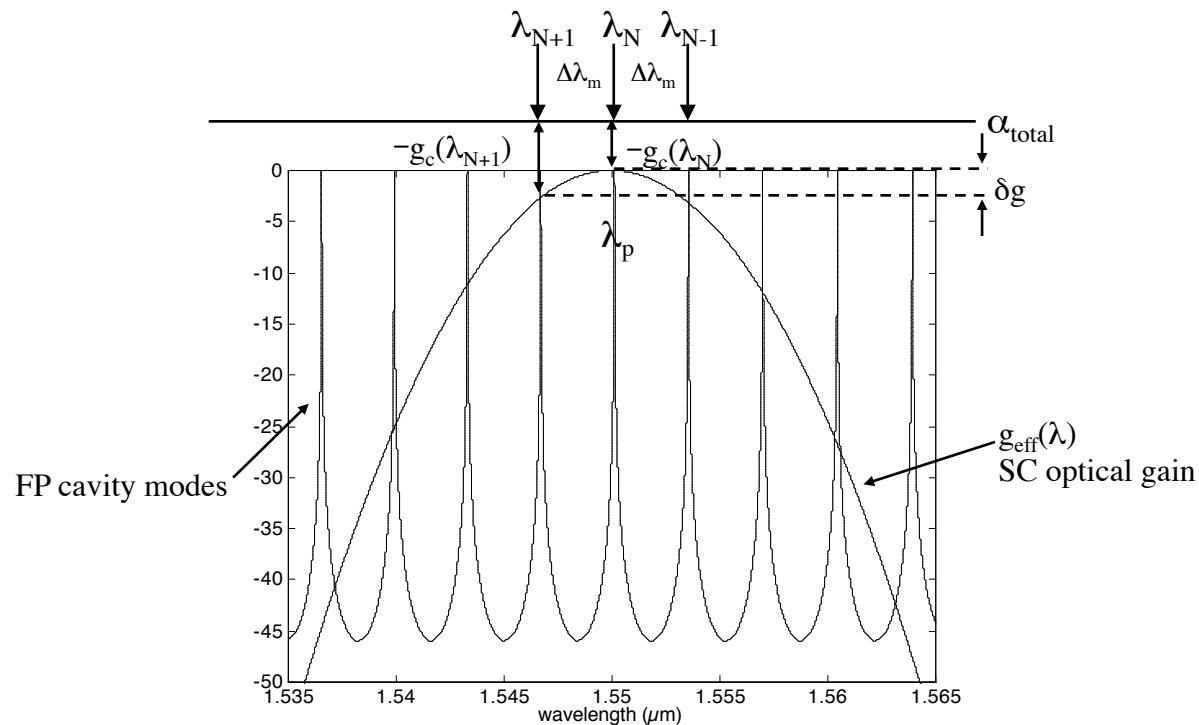

# Lecture 5: Single Mode Laser Designs

# Side Mode Suppression Ratio SMSR (1)

- ⇒ The output optical spectrum of a laser can contain one or many frequencies
- ⇒ For high performance communications (2.5Gbps and higher), it is important to use lasers that emit primarily at one frequency (wavelength).
- ⇒ The SMSR is a standard measure of how single frequency a laser is
- ⇒ Consider the following symmetrical model for a semiconductor gain medium embedded in an optical resonator where the gain peak is aligned with one of the resonator modes



# Side Mode Suppression Ratio SMSR (2)

- ⇒ Consider the time-averaged (Stationary) optical power for the dominant mode (N) and second most dominant mode (N+1)

$$\frac{d\overline{S}_N}{dt} = 0 = \Gamma_a \cdot G_N(N) \cdot (1 - \varepsilon \cdot \overline{S}_N) \cdot \overline{S}_N - \frac{\overline{S}_N}{\tau_p} + \frac{\Gamma_a \beta_{sp} N}{\tau_n}$$

$$\frac{d\overline{S}_{N+1}}{dt} = 0 = \Gamma_a \cdot G_{N+1}(N) \cdot (1 - \varepsilon \cdot \overline{S}_{N+1}) \cdot \overline{S}_{N+1} - \frac{\overline{S}_{N+1}}{\tau_p} + \frac{\Gamma_a \beta_{sp} N}{\tau_n}$$

- ⇒ The SMSR is defined as

$$\text{SMSR} = \frac{\overline{S}_N}{\overline{S}_{N+1}}$$

- ⇒ For a gain spectrum much larger than the cavity mode spacing, assume there is minimal wavelength dependence to the last term in the rate equations (assuming non-linear gain is zero)

$$\text{SMSR} = \frac{\overline{S}_N}{\overline{S}_{N+1}} = \frac{\Gamma_a \cdot G_{N+1}(N) - \frac{1}{\tau_p}}{\Gamma_a \cdot G_N(N) - \frac{1}{\tau_p}}$$

# Mode Selectivity

- ⇒ For single mode operation in a digitally modulated laser, numerical simulations of multi-mode rate equations show that the dominant mode gain must exceed gain of all other modes by order  $5 \text{ cm}^{-1}$ .

$$\Delta g_c = SMSR \frac{n_{sp}}{2} h\nu v_g \alpha_m (\alpha_i + \alpha_m) \frac{1}{P_{off}}$$

- ⇒ Where  $n_{sp}$  is the spontaneous emission factor,  $v_g$  is the mode group velocity and  $P_{off}$  is the power in a “zero” bit
- ⇒ Example:  $SMSR = 100$ ;  $n_{sp} = 3$ ;  $h\nu = 0.8\text{eV}$ ;  $v_g = c/n_{eff} = 3 \times 10^8/4$ ;  $\alpha_m = \alpha_i = 30 \text{ cm}^{-1}$ ;  $P_{off} = 0.025\text{mW}$ 
  - ⇒  $\Delta g_c = 10\text{cm}^{-1}$
- ⇒ Note: In practice it is very difficult to get (and keep) the gain peak aligned with a cavity resonance, so the SMSR not only decreases, but the laser can be unstable between two modes that are competing for the gain.

# Periodic Index Structures (1)

- ⇒ Many of the SML lasers in use today rely on some form of periodic structure to create a wavelength dependent loss designed to allow only one mode to dominate and a large resulting SMSR
  - ⇒ Examples include Distributed Bragg Reflector Laser (DBR) and the Distributed Feedback Laser (DFB)
- ⇒ A periodic structure is defined as where the index of refraction varies periodically in the direction of propagation only

$$n(z) = n'_{eff} + \frac{\Delta n}{2} \cos(2\beta_0 z)$$

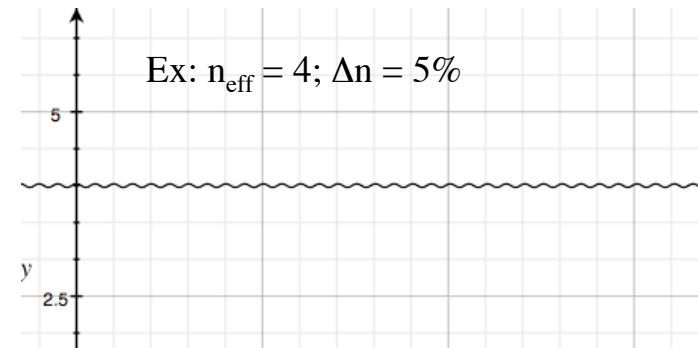

- ⇒ The Bragg period of the structure is defined as  $\Lambda = M\pi/\beta_0$ , with  $M$  an integer. For  $M=1$  (first order structure), the free space Bragg wavelength can be used to describe the Bragg period

$$\Lambda = \frac{\lambda_B}{2n'_{eff}}$$

# Periodic Index Structures (2)

- ⇒ Defining the grating vector (related to the periodic structure)  $k_g = 2\pi/\Lambda$  and the coupling coefficient  $\kappa$ , the wave equation for a field with free space propagation constant ( $k_0 = 2\pi/\lambda$ ) propagating in the periodic medium is

$$\frac{d^2 E}{dz^2} + [n(z)k_0]^2 E = \frac{d^2 E}{dz^2} + \left[ \left( n'_{eff} + \frac{\Delta n}{2} \cos(2\beta_0 z) \right) k_0 \right]^2 E = 0$$

$$\frac{d^2 E}{dz^2} + \left[ k_0^2 \left( n_{eff}^2 + n'_{eff} \Delta n \cos(2\beta_0 z) \right) \right] E = \frac{d^2 E}{dz^2} + [\beta^2 + 4\beta\kappa \cos(2\beta_0 z)] E = 0$$

$$\kappa = \frac{\pi \Delta n}{2\lambda}$$

- ⇒ Consider wavelengths  $\lambda$  close to the Bragg wavelength  $\lambda_B$  such that  $\beta = \beta_0 + \Delta\beta$  and  $\Delta\beta \ll \beta_0$
- ⇒ Using the picture below, we describe the forward and backward propagating waves by

$$E(z) = R(z)\exp(-j\beta_0 z) + S(z)\exp(j\beta_0 z)$$

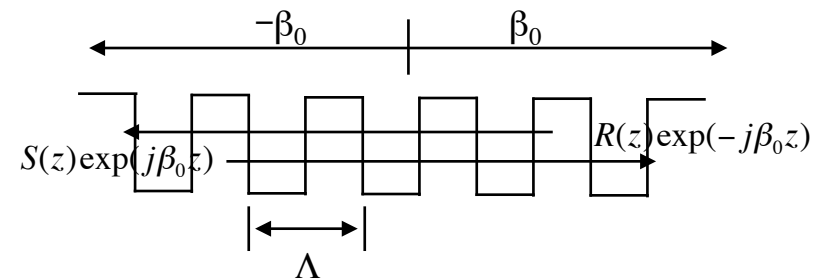

# Periodic Index Structures (3)

⇒ Inserting the backward and forward propagating field into the wave equation with periodically varying index of refraction

$$\frac{d^2 [R(z)\exp(-j\beta_0 z) + S(z)\exp(j\beta_0 z)]}{dz^2} + [\beta^2 + 4\beta\kappa \cos(2\beta_0 z)] [R(z)\exp(-j\beta_0 z) + S(z)\exp(j\beta_0 z)] = 0$$

$$\frac{d[-j\beta_0 R(z)\exp(-j\beta_0 z) + j\beta_0 S(z)\exp(j\beta_0 z) + R'(z)\exp(-j\beta_0 z) + S'(z)\exp(j\beta_0 z)]}{dz} + [\beta^2 + 4\beta\kappa \cos(2\beta_0 z)] [R(z)\exp(-j\beta_0 z) + S(z)\exp(j\beta_0 z)] = 0$$

$$-\beta_0^2 R(z)\exp(-j\beta_0 z) - \beta_0^2 S(z)\exp(j\beta_0 z) - j\beta_0 R'(z)\exp(-j\beta_0 z) + j\beta_0 S'(z)\exp(j\beta_0 z) - j\beta_0 R'(z)\exp(-j\beta_0 z) + j\beta_0 S'(z)\exp(j\beta_0 z) + \beta^2 R(z)\exp(-j\beta_0 z) + \beta^2 S(z)\exp(j\beta_0 z) + 4\beta\kappa \cos(2\beta_0 z) R(z)\exp(-j\beta_0 z) + 4\beta\kappa \cos(2\beta_0 z) S(z)\exp(j\beta_0 z) = 0$$

$$(\beta^2 - \beta_0^2) R(z)\exp(-j\beta_0 z) + (\beta^2 - \beta_0^2) S(z)\exp(j\beta_0 z) - 2j\beta_0 R'(z)\exp(-j\beta_0 z) + 2j\beta_0 S'(z)\exp(j\beta_0 z) + 4\beta\kappa \cos(2\beta_0 z) R(z)\exp(-j\beta_0 z) + 4\beta\kappa \cos(2\beta_0 z) S(z)\exp(j\beta_0 z) = 0$$

$$\exp(-j\beta_0 z) [(\beta^2 - \beta_0^2) - 2j\beta_0 R'(z) + 4\beta\kappa \cos(2\beta_0 z) R(z)] + \exp(j\beta_0 z) [(\beta^2 - \beta_0^2) + 2j\beta_0 S'(z) + 4\beta\kappa \cos(2\beta_0 z) S(z)] = 0$$

$$\beta^2 = \beta_0^2 + \Delta\beta^2 + 2\beta_0\Delta\beta \cong \beta_0^2 + 2\beta_0\Delta\beta$$

$$\exp(-j\beta_0 z) [2\beta_0\Delta\beta - 2j\beta_0 R'(z) + 4\beta\kappa \cos(2\beta_0 z) R(z)] + \exp(j\beta_0 z) [2\beta_0\Delta\beta + 2j\beta_0 S'(z) + 4\beta\kappa \cos(2\beta_0 z) S(z)] = 0$$

⇒ Which can be described by the coupled-mode equations

$$R'(z) + j\Delta\beta R(z) = -j\kappa S(z)$$

$$S'(z) - j\Delta\beta S(z) = j\kappa R(z)$$

# Solution to Coupled Mode Equations (1)

- ⇒ The coupled mode equations and wave equation describe the field in the periodic index structure.
- ⇒ Assuming there are boundary conditions (e.g.  $R(0)$  and  $S(0)$  are known), we can write the fields as

$$R(z) = \left[ \cosh(\gamma z) - \frac{j\Delta\beta}{\gamma} \sinh(\gamma z) \right] R(0) - \frac{j\kappa}{\gamma} \sinh(\gamma z) S(0)$$

$$S(z) = \frac{j\kappa}{\gamma} \sinh(\gamma z) R(0) + \left[ \cosh(\gamma z) + \frac{j\Delta\beta}{\gamma} \sinh(\gamma z) \right] S(0)$$

where at  $z = L$

$$R(L) = \left[ \cosh(\gamma L) - \frac{j\Delta\beta}{\gamma} \sinh(\gamma L) \right] R(0) - \frac{j\kappa}{\gamma} \sinh(\gamma L) S(0)$$

$$S(L) = \frac{j\kappa}{\gamma} \sinh(\gamma L) R(0) + \left[ \cosh(\gamma L) + \frac{j\Delta\beta}{\gamma} \sinh(\gamma L) \right] S(0)$$

$$\begin{pmatrix} R(L) \\ S(L) \end{pmatrix} = F_{per}(L) \begin{pmatrix} R(0) \\ S(0) \end{pmatrix}$$

- ⇒ Where we have defined the matrix  $F_{per}(L)$  and  $\gamma^2 = \kappa^2 - \Delta\beta^2$
- ⇒ Note that  $F_{per}$  relates the right and left propagating waves at the left side ( $z=0$ ) of the periodic index structure to the right and left propagating waves at the right side ( $z=L$ ) of the structure.



# Solution to Coupled Mode Equations (2)

⇒ We can define the field reflection coefficient  $r_{per}$  and the power reflection coefficient  $R_{per}$  at  $z=0$  as

$$r_{per} = \frac{S(0)}{R(0)} = \frac{-\frac{j\kappa}{\gamma} \sinh(\gamma L)}{\left[ \cosh(\gamma L) + \frac{j\Delta\beta}{\gamma} \sinh(\gamma L) \right]} \approx \frac{-j\kappa L}{[1 + j\Delta\beta L]}$$

$$R_{per} = |r_{per}|^2 \approx \begin{cases} (\kappa L)^2 \frac{\sin^2 \sqrt{(\delta L)^2 - (\kappa L)^2}}{(\delta L)^2 - (\kappa L)^2}, & \text{for } \delta L \gg \kappa L \\ \tanh^2 \sqrt{(\delta L)^2 - (\kappa L)^2}, & \text{for } \delta L \approx \kappa L \end{cases}$$

⇒ Where the final simplification for  $r_{per}$  is for  $\kappa L$  very close to  $\Delta\beta L$

⇒ Note that

- ⇒  $|r_{per}|$  increases with increasing  $\kappa L$  which means a higher coupling coefficient leads to a stronger reflection.
- ⇒  $|r_{per}|$  decreases with increasing  $\Delta\beta L$  which means the reflection becomes smaller when the wavelength moves away from the Bragg reflection peak.
- ⇒ The reflection experiences a  $\pi/2$  phase shift when  $\Delta\beta = 0$ .

# Distributed Bragg Reflector (DBR) Lasers (1)

- ⇒ Bragg reflector acts as wavelength dependent mirror
- ⇒ Long gratings and weak coupling coefficient realizes a mirror with high reflectivity and narrow reflection peak (spectrum)
- ⇒ The gain condition and net modal gain can be written as  $R_1 R_{per} \exp(2g_{net} L_A) = 1$

$$g_{net} = \frac{1}{2L_A} \left[ \ln \frac{1}{R_1} + \underbrace{\ln \frac{1}{R_{per}}}_{\text{Power that leaves active region at } z=0} \right]$$

Power that leaves active region at  $z=0$

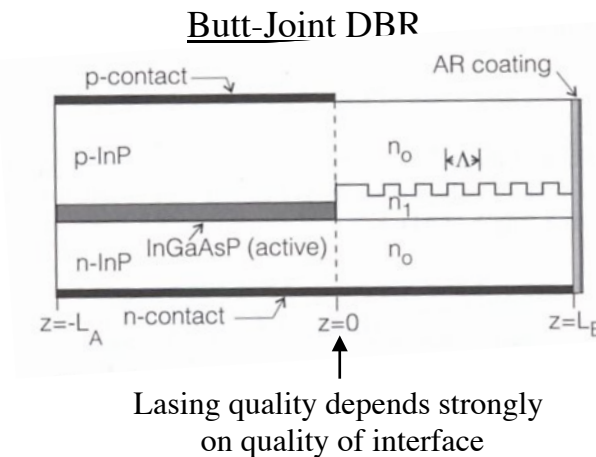
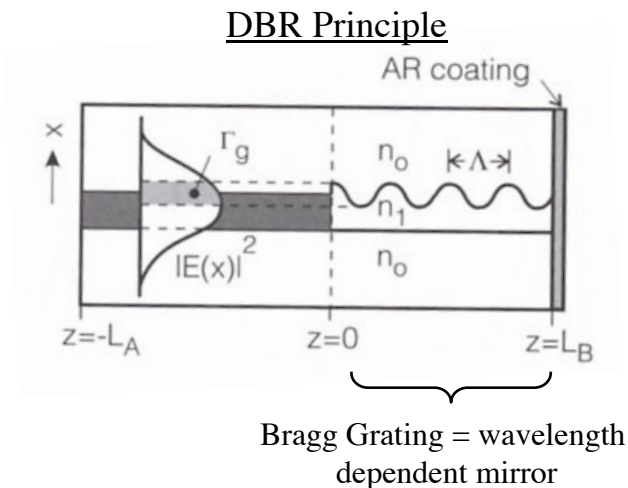

# Distributed Bragg Reflector (DBR) Lasers (2)

- ⇒ To understand how the reflectivity varies as the wavelength shifts away from the Bragg wavelength, we introduce the normalized parameter

$$\Delta\beta = \beta - \beta_0 = \frac{2\pi n'_{eff}(\lambda)}{\lambda} - \frac{2\pi n'_{eff}(\lambda_B)}{\lambda_B} \approx \frac{2\pi n_g}{\lambda_B^2} \Delta\lambda$$

$$n_g = \left. \frac{d(k_0 n'_{eff})}{dk_0} \right|_{\lambda_B}$$

- ⇒ At wavelengths near the Bragg wavelength, a periodic structure of length L, and an incoming field of magnitude R(0) at z=0 and S(L) = 0 at z=L

$$R(z) = \frac{\cosh(\kappa(z-L))}{\cosh(\kappa L)} R(0)$$

$$S(L) = \frac{j \sinh(\kappa(z-L))}{\cosh(\kappa L)} R(0)$$

$$|R(z)|^2 - |S(z)|^2 = |R(L)|^2$$

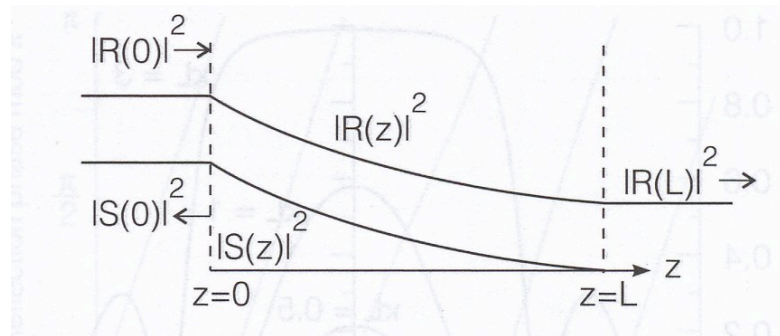

# Distributed Bragg Reflector (DBR) Lasers (2)

⇒ At the Bragg wavelength,  $\Delta\beta=0$ , which means  $\gamma = \kappa$ , and the reflectivity only depends on  $\kappa L$

$$|r_{per}| = \left| \frac{S(0)}{R(0)} \right| = \left| \frac{-j \sinh(\kappa L)}{\cosh(\kappa L)} \right| = \tanh(\kappa L)$$

$$R_{per} = |r_{per}|^2 = \tanh^2(\kappa L)$$

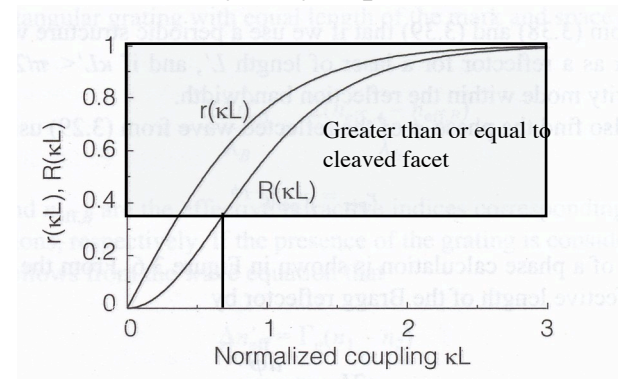

⇒ If we now look at the reflectivity as a function of wavelength offset from the Bragg wavelength as a parameter of  $\kappa L$ . The reflectivity function is periodic with nulls at (assuming  $\Delta\beta L > \kappa L$ )

$$\Delta\beta L = \sqrt{(\kappa L)^2 + (N\pi)^2}, \text{ for } N = 1, 2, \dots,$$

⇒ The reflection bandwidth for the Bragg mirror is

$$\Delta\lambda_r = \frac{\lambda_B^2 \kappa}{\pi n_{g,eff}} = \frac{\lambda_B \Delta n}{2 n_{g,eff}}$$

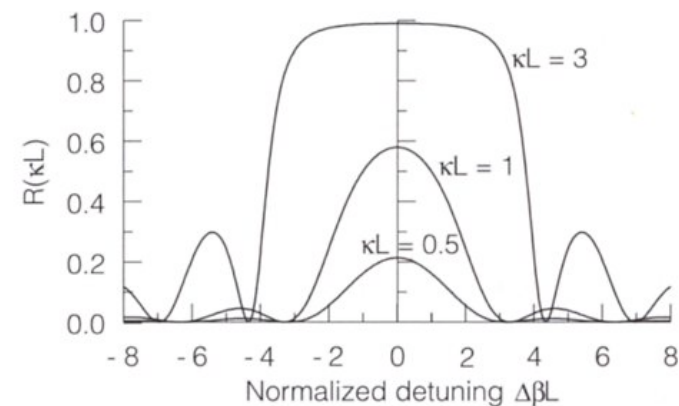

# Distributed Bragg Reflector (DBR) Lasers (3)

- ⇒ Recall that in this design the Bragg mirror is only one of the mirrors. The other mirror is a broadband FP type mirror. There are designs where a Bragg mirror is used for both mirrors.
- ⇒ A key question is then, how many FP modes are there within the primary reflection mode of the Bragg mirror? If there is more than one, then we will not have a single mode laser
- ⇒ Lets plug in the coupling coefficient into the standard mode spacing equation for a FP laser

$$\Delta\lambda_m = \frac{\lambda^2}{2n_{g,eff}L} > \frac{\lambda_B^2\kappa}{\pi n_{g,eff}} = \Delta\lambda_r$$

- ⇒ Single mode operation occurs when only one cavity mode fits under the Bragg reflector bandwidth, or

$$\kappa L < \pi/2$$

# Distributed Feedback (DFB) Lasers

- ⇒ DFB lasers employ Bragg mirrors. The mirror is “distributed” through the laser gain medium instead of at the ends like with DBR lasers.
- ⇒ First consider the case of a DFB laser with non-reflecting facets (e.g. semiconductor facets are highly AR coated)

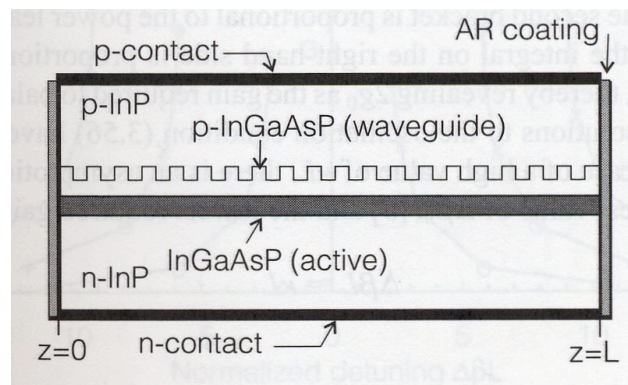

- ⇒ To allow for the presence of gain, we need to modify  $\Delta\beta$  with  $\Delta\beta + jg_0$ . In this example there are no mirrors, so the matrix  $F_{per}$  describes the fields and the oscillation condition for lasing is  $(F_{per})_{22} = 0$ .

$$F_{per} = \begin{pmatrix} \left[ \cosh(\gamma L) - \frac{j\Delta\beta}{\gamma} \sinh(\gamma L) \right] & -\frac{j\kappa}{\gamma} \sinh(\gamma L) \\ \frac{j\kappa}{\gamma} \sinh(\gamma L) & \left[ \cosh(\gamma L) + \frac{j\Delta\beta}{\gamma} \sinh(\gamma L) \right] \end{pmatrix}$$

$$(F_{per})_{22} = 0$$

$$\cosh(\gamma L) + \frac{j(\Delta\beta + jg_0)}{\gamma} \sinh(\gamma L) = 0$$

# Distributed Feedback (DFB) Lasers

- ⇒ The wave equation sets the relation between gain and the distributed mirror parameters as

$$\gamma^2 = \kappa^2 - (\Delta\beta + jg_0)^2$$

- ⇒ And the oscillation condition can be written as

$$\gamma L \coth(\gamma L) = -j(\Delta\beta L + jg_0 L)$$

- ⇒ The gain and phase for the DFB are tightly coupled in contrast to the FP laser. The complex number in the above equation determines the gain and phase. The coupling coefficient and length together determine the possible values for  $\Delta\beta L$  and  $g_0 L$ . The oscillation condition will yield a set of solutions, each with a wavelength (given by  $\Delta\beta$ ) and gain for that wavelength (given by  $g_0$ ).