

# Lecture 11: Wavelength Conversion

# Optical Wavelength Conversion



- ⇒ Process of transferring data from one optical wavelength to another without modifying the content of the data
- ⇒ Two main approaches
  - ⇒ Optical electronic
    - ⇒ Optoelectronic optical (OEO)
    - ⇒ Optoelectronic IC (OEIC)
  - ⇒ All-Optical
- ⇒ Each approach employs one or a combination of physical “nonlinear” process to transfer data between wavelengths
  - ⇒ Free carrier modulation (governed by carrier dynamics)
  - ⇒ Bound carrier modulation (ultra-fast response time  $> 1\text{THz}$ )
  - ⇒ Field modulation

# Optical Wavelength Conversion Metrics

Metric	Description
Modulation and Format Transparency	The range of modulation techniques and bit formats that can be transferred from the input to the output (incoherent, coherent, multi-level, RZ, NRZ, etc)
Bit Rate Transparency	The range of bit rates (hi and low) that the converter will operate without major adjustments
Conversion Efficiency	Average power in the output wavelength relative to the input wavelength
Conversion Extinction Ratio	Ratio of the average power in the original and new wavelengths at output
Modulation Extinction Ratio	Ratio of the power in the “one” bit to the “zero” bit at the output converted wavelength
Input Optical Bandwidth	Range of input wavelengths over which required optical performance at output can be achieved
Output Optical Bandwidth	Range of output wavelengths (converted)
Self-Conversion	Ability to convert input wavelength to same wavelength at output
Input Dynamic Range	Range of optical input power at original wavelength that achieves required performance
Polarization Dependence	Sensitivity in optical output signal (efficiency, etc.) to changes in input polarization state
Sensitivity	Minimum optical power at input to achieve minimum required BER
Regenerative Capability	1R, 2R or 3R regenerative or regenerative capable
Polarity	Inverting and/or non-inverting digital operation
Noise Figure	Ratio of input to output SNR
Chirp and RIN Penalty	Addition of chirp or RIN to output signal relative to input signal

# Wavelength Conversion Processes

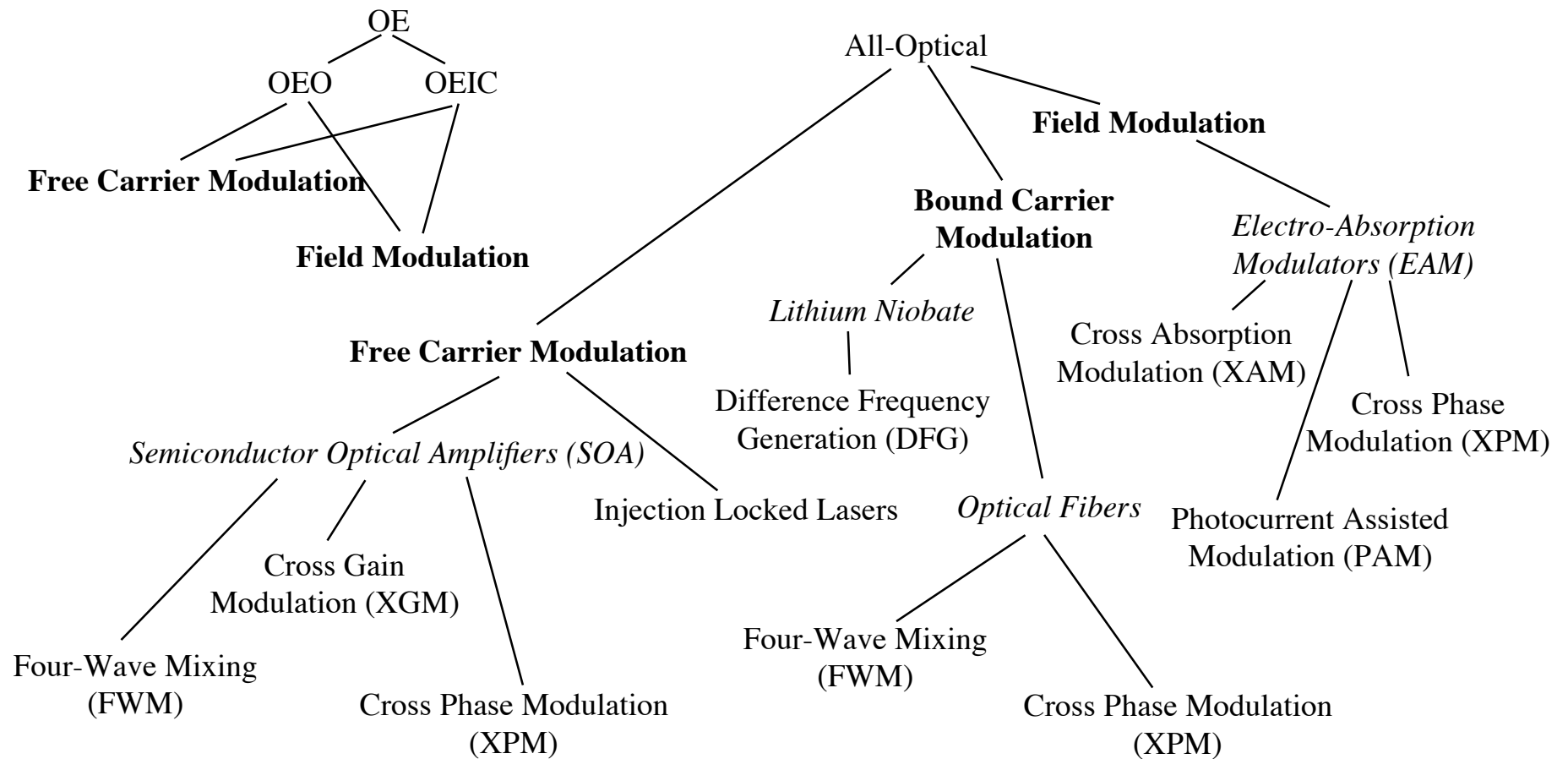

# Wavelength Converter Function

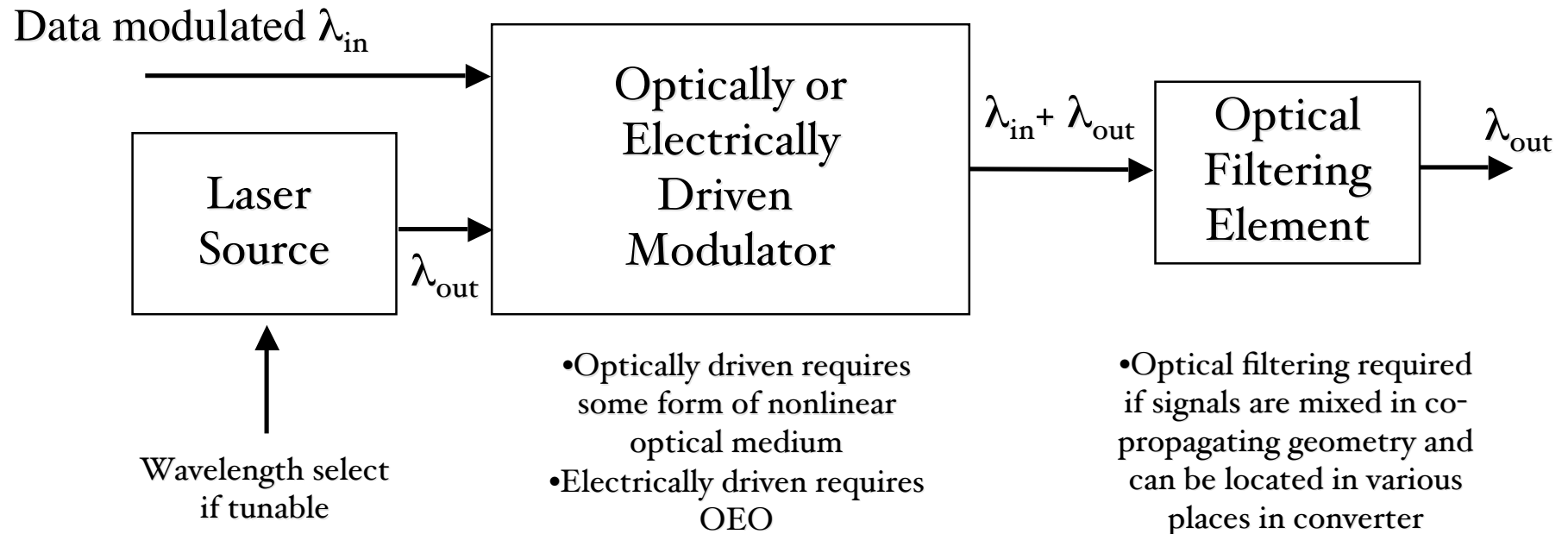

# OEO

- ⇒ Data is fully converted to electronics
- ⇒ Electronic thresholding is used to re-shape the data (2R) and/or clock recovery is used to re-shape and re-time (3R)
- ⇒ Laser and external modulator (or direct modulation) is used to re-transmit regenerated data on new wavelength
- ⇒ Digital logic largely decouples design requirements for detector and modulator

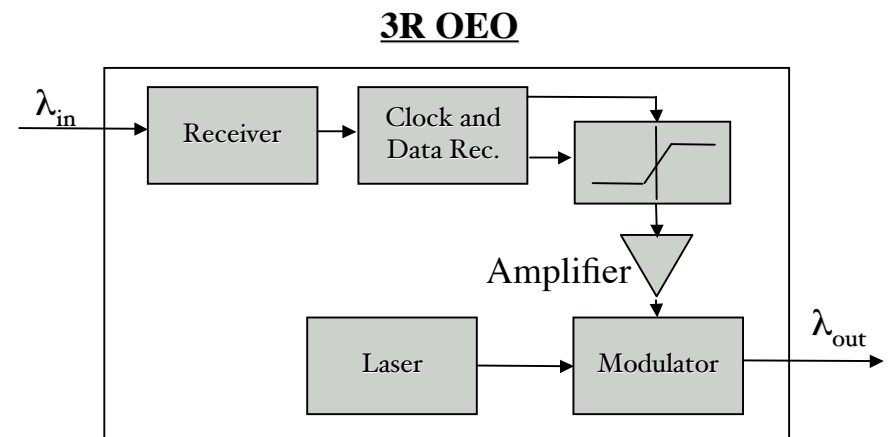
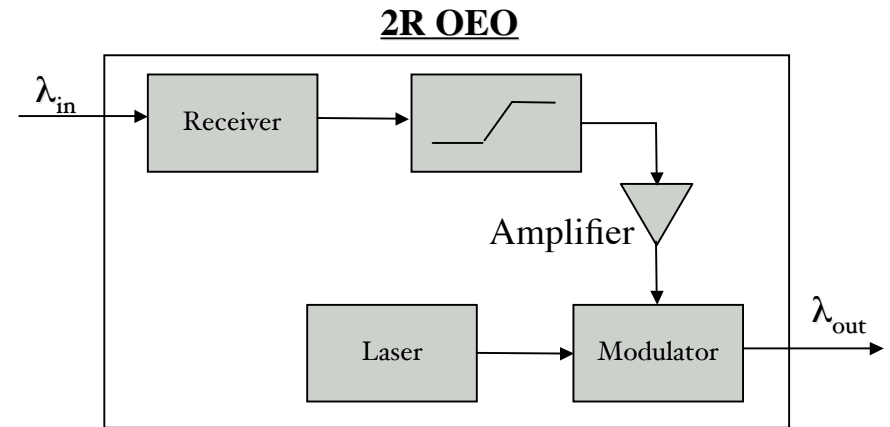

# OEIC

- ⇒ This technique involves a back-to-back detector/externally modulated laser. Data is converted (as in OEO) to electronic domain and used to re-modulate as laser. The difference is that no electronics are placed in between the detector and laser.
- ⇒ The design of the detector and modulator each have unique set of constraints. Hardwiring the two together means there has to be a balancing of the requirements for optimal detection and modulation.

Direct Drive Configuration

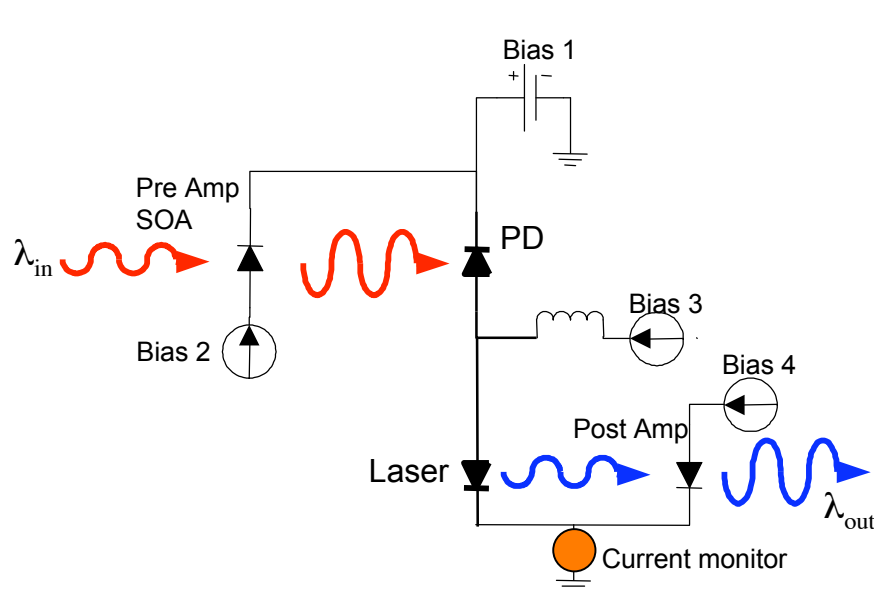

External Modulator Configuration

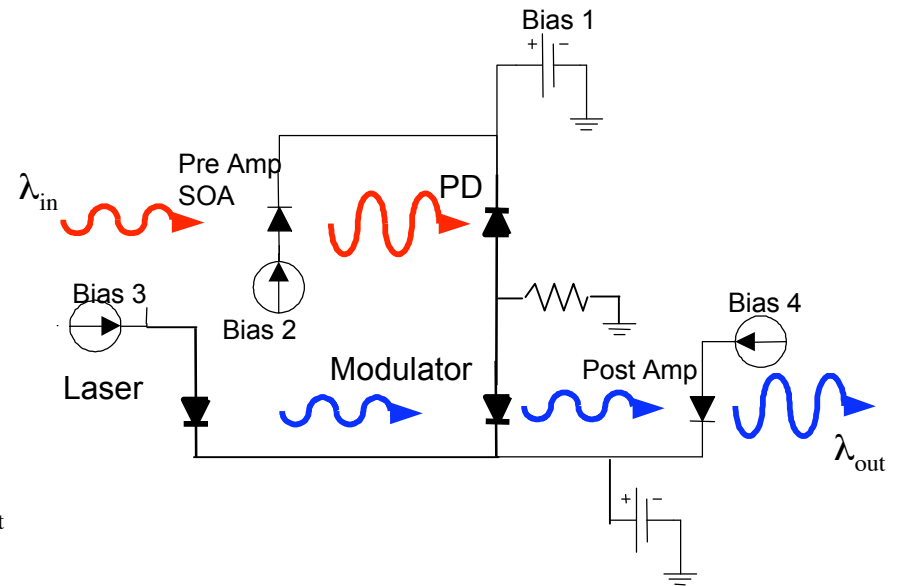

# OEIC

## ⇒ Issues

- ⇒ Optical pre-amplification critical to boost input signal in shot noise limit for photodetector
- ⇒ Optical-preamplifier must be linear (no distortion, no bit-patterning)
- ⇒ Photodetector must be designed to balance speed, responsivity and ability to drive large enough photocurrent with output load.

## ⇒ Approaches

Integrated uni-traveling carrier photodiodes, high saturation power SOAs, tunable laser and EAM

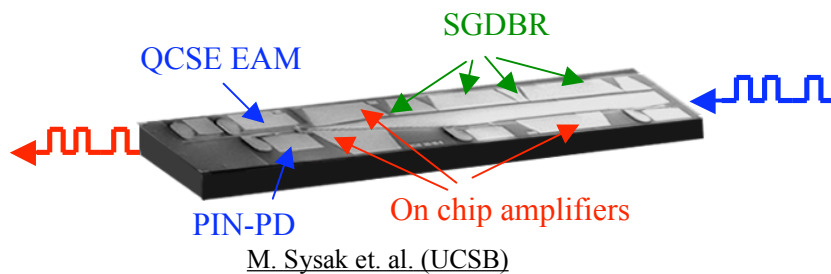

Hybrid SOA preamplified receiver and MZ Interferometer (MZI) tunable transmitter

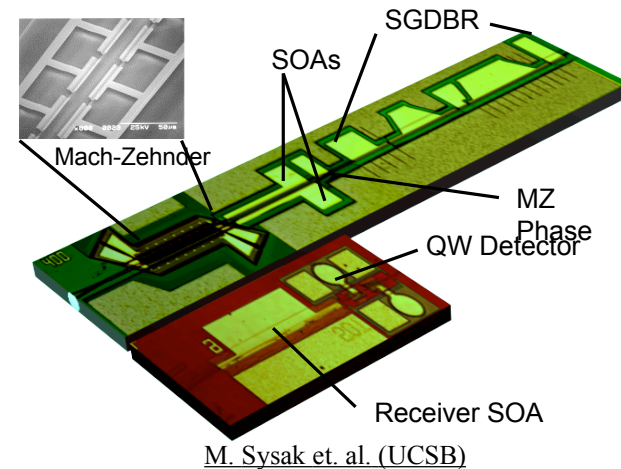



# Free Carrier All-Optical: SOAs



- ⇒ Semiconductor Optical Amplifiers (SOAs)
  - ⇒ Intensity of data modulation produces changes in gain (and phase via Kramers-Kronig) in the SOA
  - ⇒ Input driven changes in gain (phase) in SOA can be used to modulate information onto new optical carrier supplied by local laser source (can be tunable).

# SOA Cross Gain Modulation (XGM)

- ⇒ Input data is intensity modulated on  $\lambda_{in}$  (probe). Induces gain compression in the SOA that is seen by  $\lambda_{out}$  (signal).
- ⇒ Data is inverted
- ⇒ Extinction ratio at output is lower than at input
- ⇒ Asymmetry in wavelength up-conversion vs. down-conversion due to wavelength dependent saturation power
- ⇒ Co-propagating probe and signal need for high bit rate (>10Gbps) operation. Therefore need filter for signal separation.

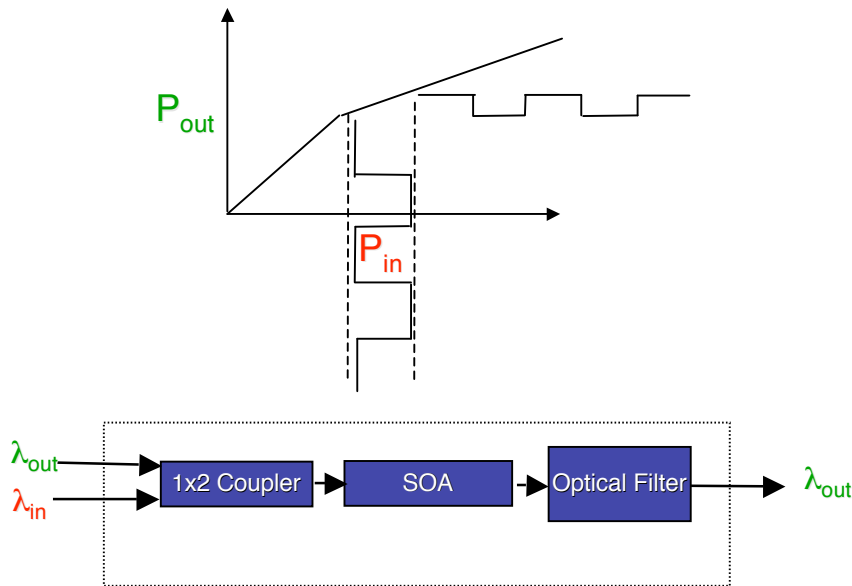

SOA Power Spectrum with and without signal ( $I_{bias} = 150mA$ )

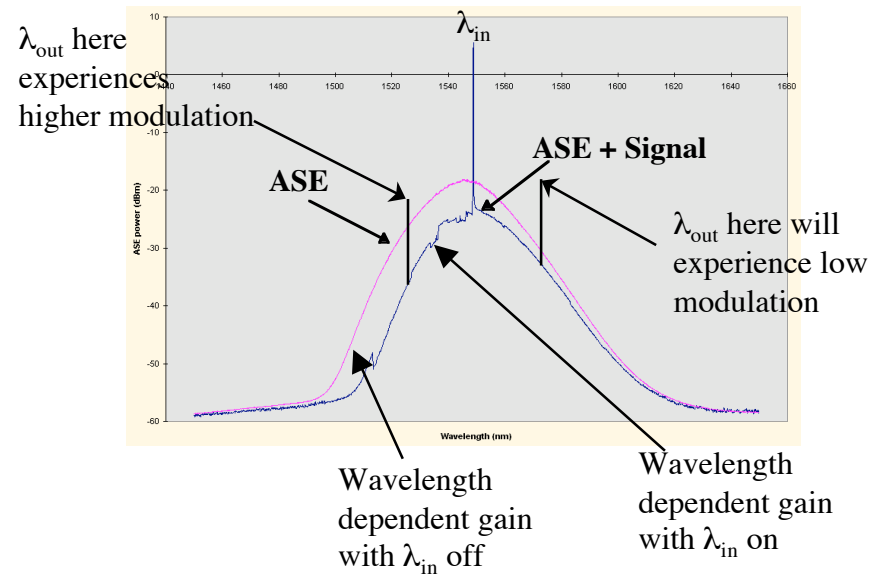

# SOA Cross-Phase Modulation (XPM)



- ⇒ Here the time change in phase due to intensity change in optical input is utilized.
- ⇒ If the input signal is intensity (on-off) modulated, since the SOA produce a phase modulated output signal there needs to be a secondary modulation conversion step
  - ⇒ Input intensity modulation -> SOA phase modulation -> output intensity modulation
  - ⇒ This is usually accomplished by placing an optical filter at the SOA output
  - ⇒ Since the conversion from intensity to phase depends on time rate of change in the input signal, this technique tends to work better for RZ coded data

# SOA XPM Wavelength Conversion

- ⇒ The nonlinear induced phase shift in the SOA of length  $L$  (given by  $\gamma$ ) will be due to instantaneous power in both  $\lambda_{in}$  and  $\lambda_{out}$

$$\phi_{NL}(\lambda_{out}) = \gamma L [P(\lambda_{in}) + P(\lambda_{out})]$$

- ⇒ The change seen by  $\lambda_{out}$  will be due to changes in both signals. The change in  $\lambda_{out}$  due to  $\lambda_{out}$  is self-phase modulation (SPM) and the change in  $\lambda_{out}$  due to  $\lambda_{in}$  is XPM.
- ⇒ The time induced phase change (due to XPM and SPM of the data pulses) will lead to instantaneous frequency shift

$$f(t) = \frac{d\phi_{NL}}{dt}$$

- ⇒ This shift, illustrated on the right, can be filtered (separated) from the unshifted spectrum using an optical bandpass filter (BPF).
- ⇒ The BPF also serves the purpose of probe-signal separation and to threshold the signal (2R)
- ⇒ We see that this operation is “non-inverting”, in contrast to the XGM approach.

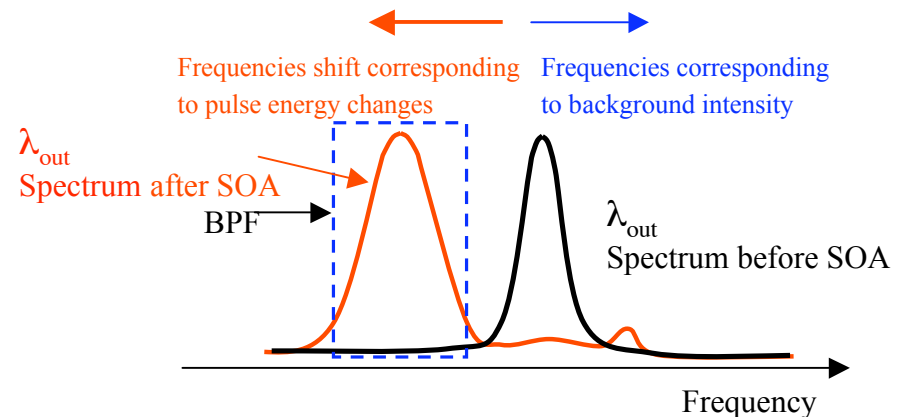
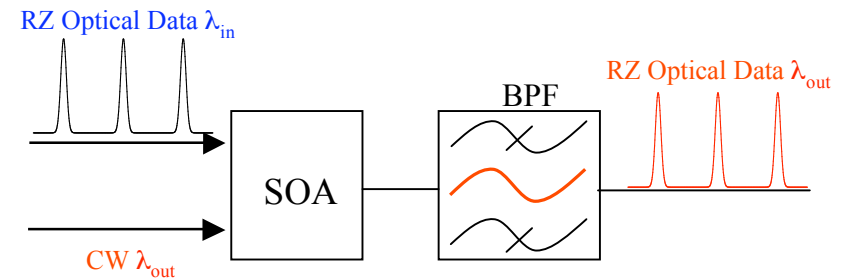

# SOA Four Wave Mixing

- ⇒ The gain of the SOA can respond to very fast fluctuations in the optical signals.
- ⇒ Carrier population fluctuations can occur band to band, DCH and/or SHB.
- ⇒ Two signals at pump ( $\omega_p$ ) and probe ( $\omega_q$ ) interfere to generate a moving intensity grating  $\Omega$  that creates moving gain and phase gratings along the SOA waveguide. Since the response of carriers is very fast,  $\Omega$  can be very large.
- ⇒ The photons at  $\omega_p$  are then scattered (or phase and gain modulated) by these gratings, with new energy at the signal frequency ( $\omega_s$ )
- ⇒ Since the SOA has gain  $G$ , the efficiency is improved by  $G^3$  over FWM without gain.
- ⇒ Information modulated onto the probe ( $\omega_q$ ) will be transferred over to  $\omega_s$  (but mirrored). Therefore any modulation type will work (coherent or incoherent).

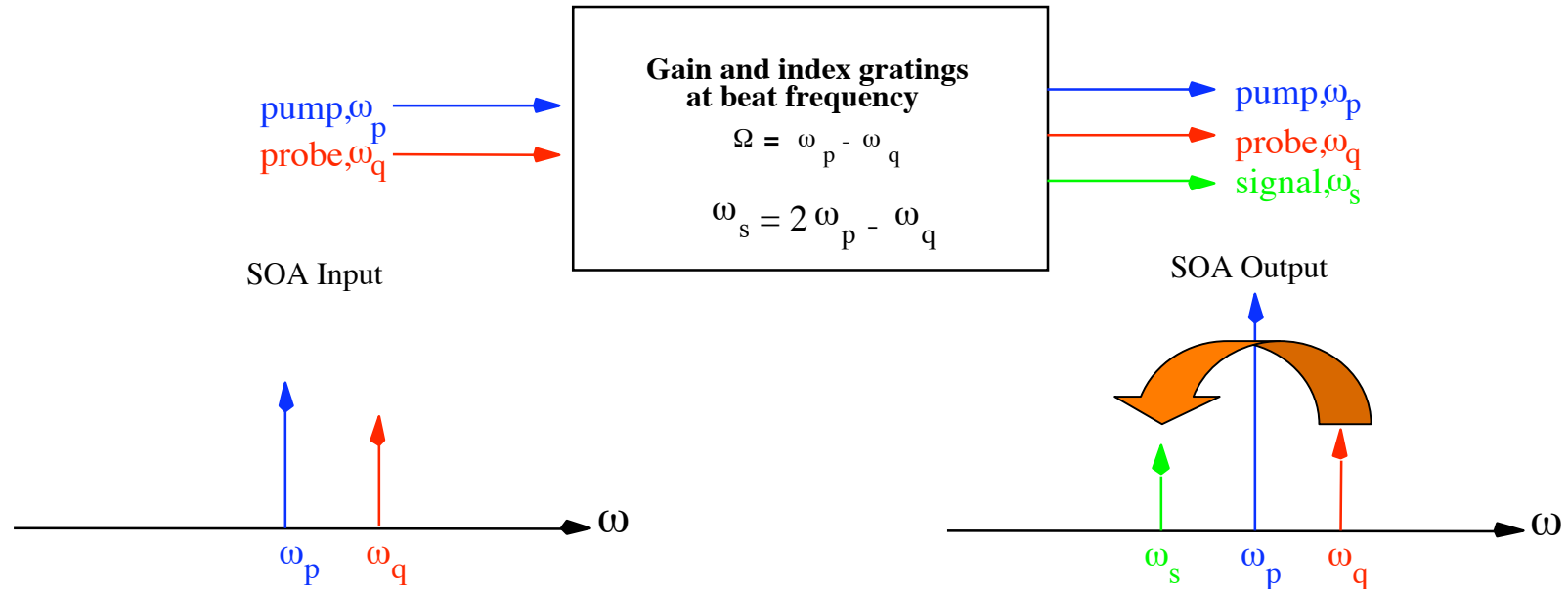

# Interferometric SOA Wavelength Converters

- ⇒ The performance of simple XGM and SPM converters limit their operation in real applications
  - ⇒ Extinction ratio
  - ⇒ Inverting vs. Non-inverting operation
  - ⇒ Self-wavelength conversion and optical bandwidth
  - ⇒ Bit-Rate
- ⇒ Embed the SOA inside an interferometer to “enhance” or make more digital, the wavelength conversion process -> Interferometric Wavelength Converter (IWC)
- ⇒ Many approaches
  - ⇒ Michaelson Interferometer WC (MI SOA-WC)
  - ⇒ Mach-Zehnder Interferometer (MZI SOA-WC)
  - ⇒ Sagnac loop mirror SOA-WC
  - ⇒ Asymmetric loop mirror WC (TOAD)
- ⇒ There are also techniques employed to increase the speed of SOA based WCs beyond limits imposed by carrier recovery lifetime
  - ⇒ Differentially driven IWCs

# Michaelson Interferometer SOA-WCs

- ⇒ When  $n_{\text{eff}}L_1$  and  $n_{\text{eff}}L_2$  are exactly matched, input appears at output.
- ⇒ When  $n_{\text{eff}}L_1$  and  $n_{\text{eff}}L_2$  are  $\pi$  out of phase, input is “reflected” back to input.
- ⇒ Using a second data modulated signal that is input through a partially reflecting mirror, into an SOA, the path length is changed through XPM
- ⇒ Data modulated signal changes path length difference between 0 and  $\pi$ .
- ⇒ SOA in second arm is used to balance losses for maximum contrast (on-off) ratio.

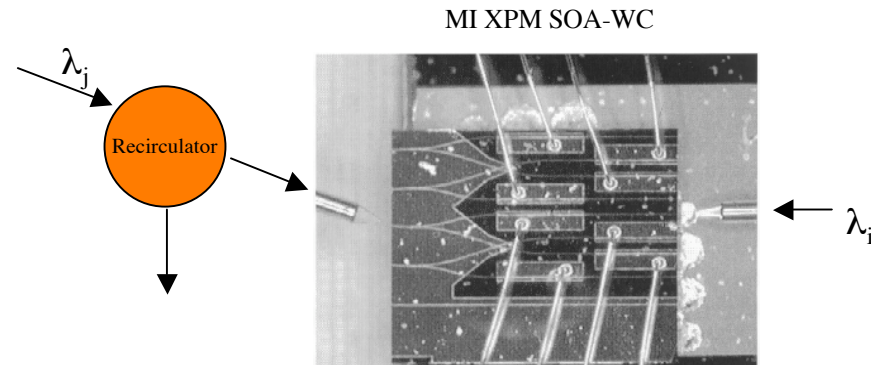
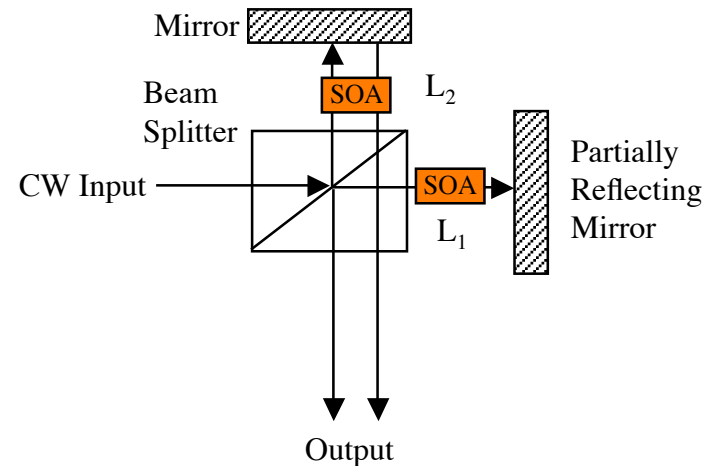

# MZI SOA-WCs

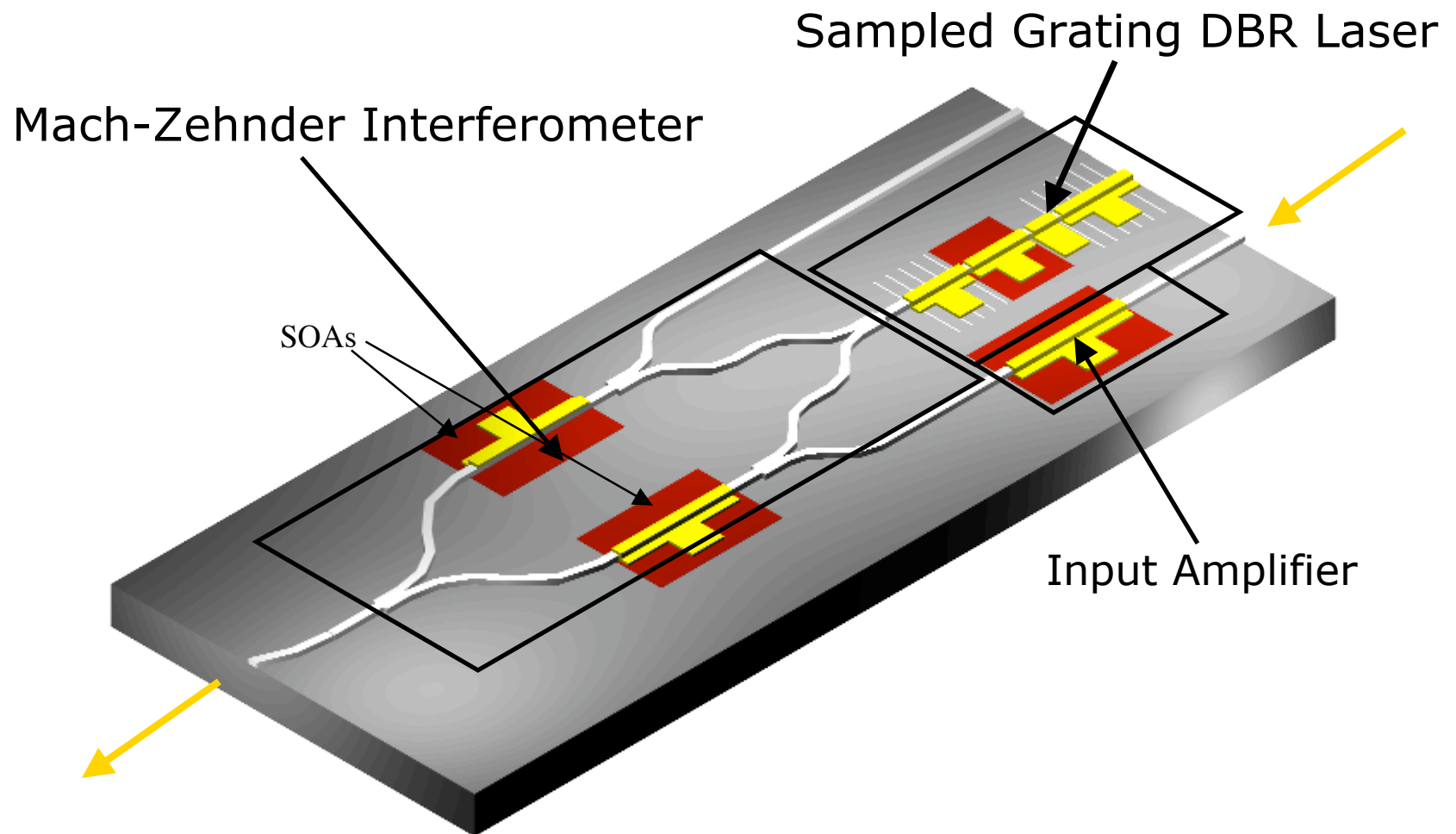



# MZI SOA-WCs

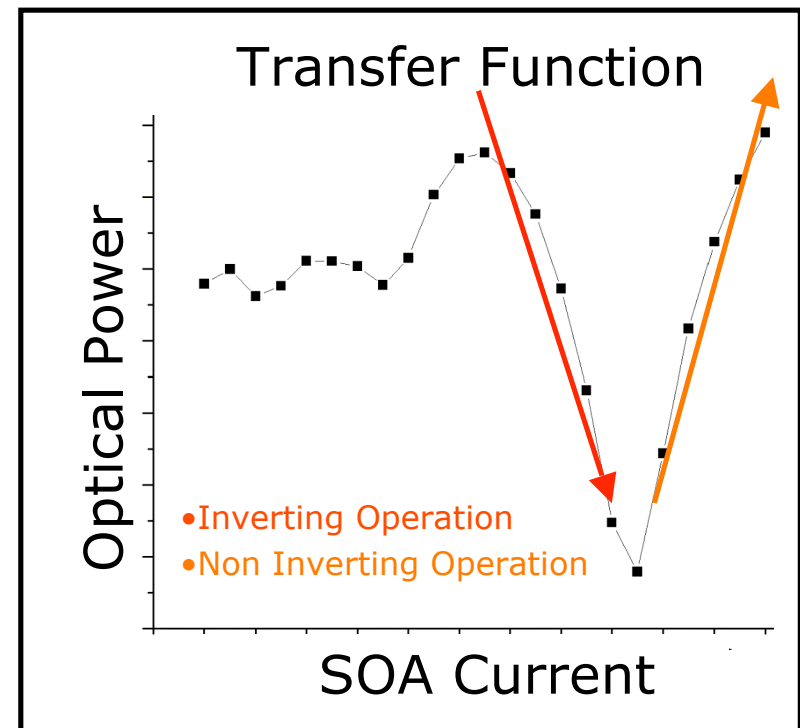
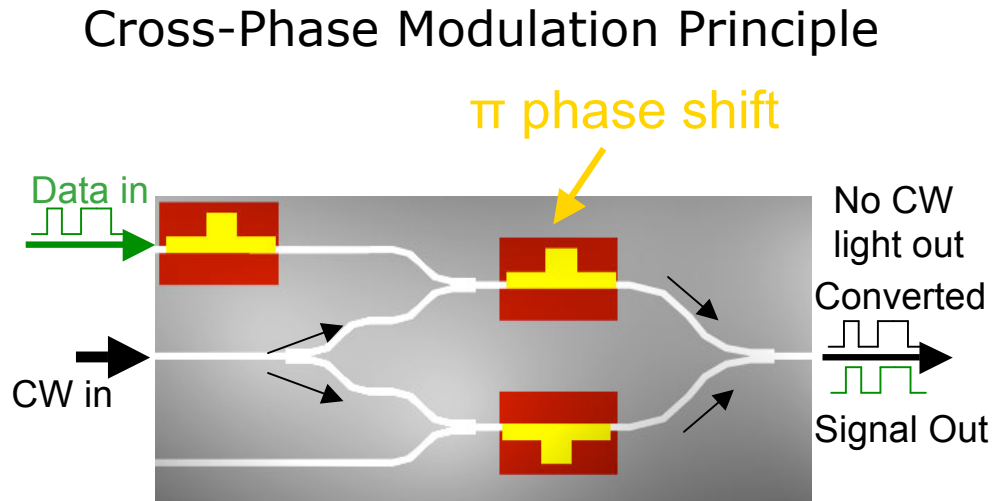

# MZI SOA-WC Differential Operation

Input Pulse

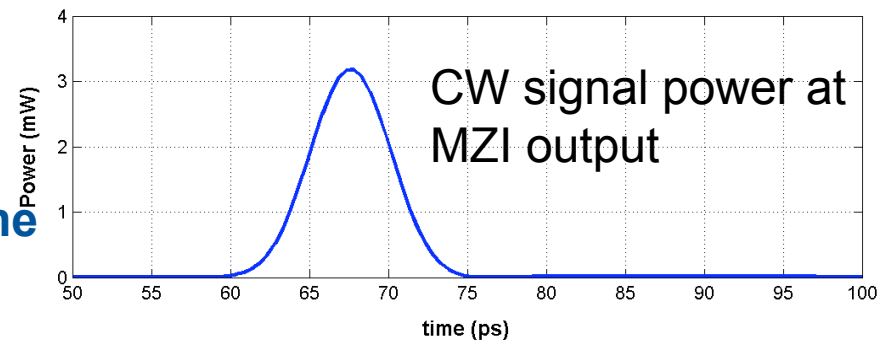
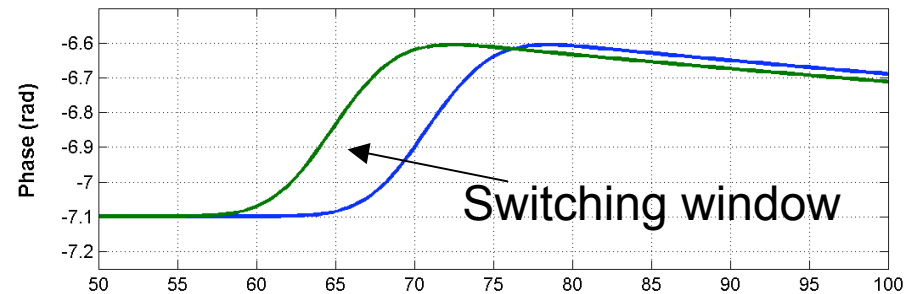
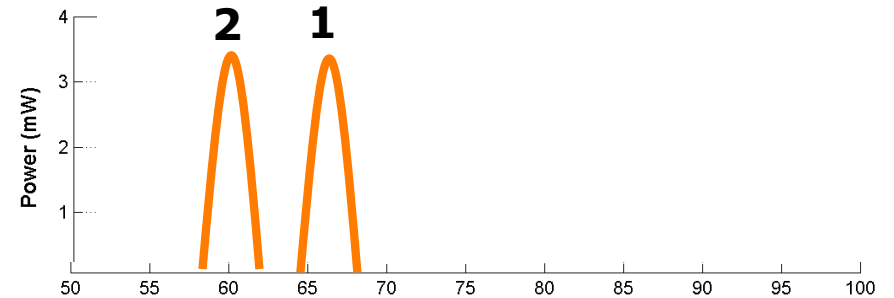
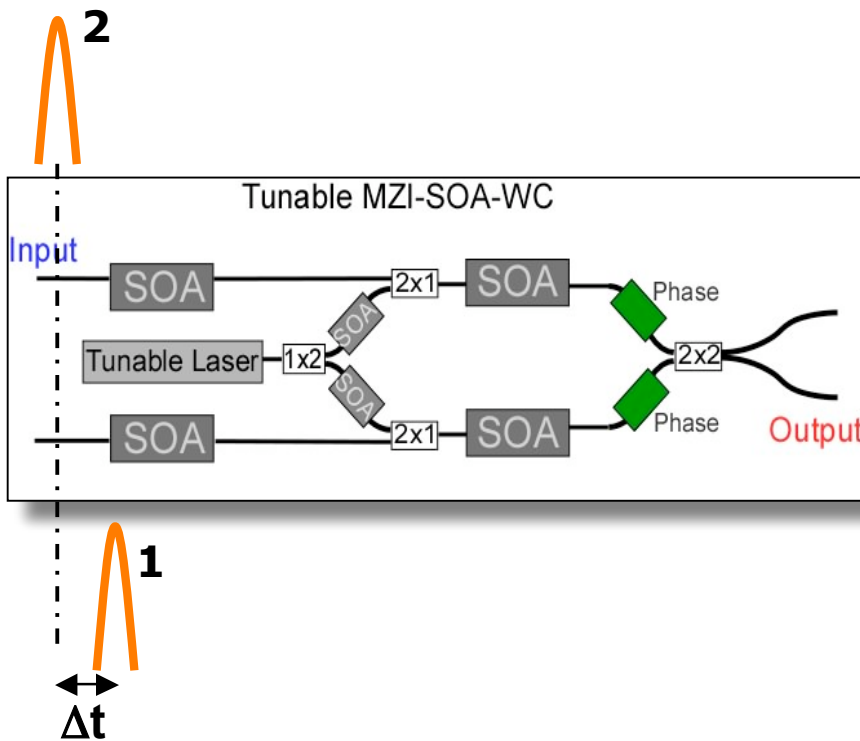

- Differential operation used to overcome slow gain recovery lifetimes

# Loop Mirror Configurations

- ⇒ Similar operation as MI, but shared arm instead of two arms.
- ⇒ More stable since one arm only
- ⇒ Two names given to this structure:
  - ⇒ UNI when SOA is centered
  - ⇒ TOAD when SOA is off-center
- ⇒ CW input is reflected or passed through based on phase shift imbalance between counter propagating waves in interferometer.

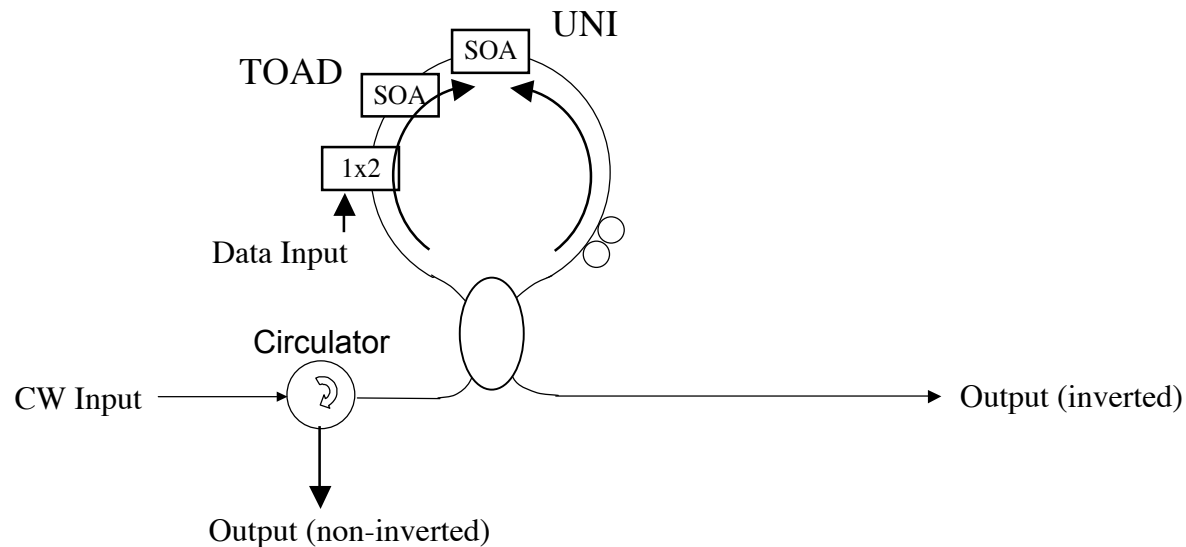

# Laser Injection Locking

- ⇒ Laser output set by mirror tuning
- ⇒ Injecting data modulated signal into gain section changes gain of lasing wavelength
- ⇒ Gain can be modulated on/off with input optical signal.

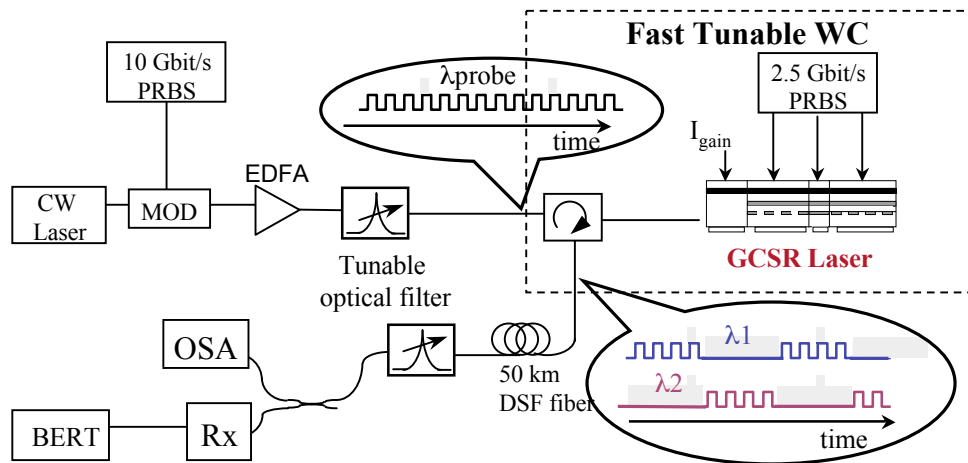

O. Lavrova (UCSB)

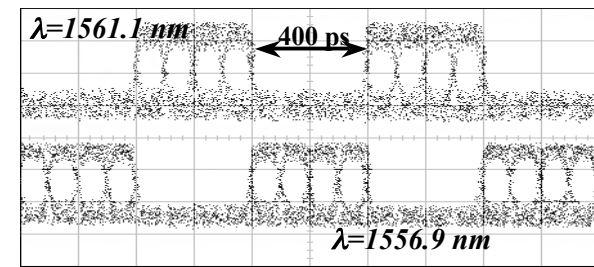

10 Gbps WC at 2.5 Gbps switching rate between 2 output  $\lambda$ s