

A 50 GHz Broadband Differential Amplifier with Transferred-Substrate HBTs

B. Agarwal, Q. Lee, R. Pallela, D. Mensa, J. Guthrie and M. J. W. Rodwell

Department of ECE, University of California, Santa Barbara, CA 93106

805-893-8044, 805-893-3262 FAX, rodwell@schottky.ece.ucsb.edu

Fiber-optic receivers require considerable amplification between the transimpedance preamplifier stage output and the decision circuit input [1,2]. The gain and group delay must be substantially flat over a bandwidth extending from a few KHz up to $\sim 70\%$ of the data rate. AGC or *symmetric* limiting characteristics are also required. To meet these requirements, broadband multistage differential amplifiers are generally employed. This paper presents a broadband differential amplifier in the AlInAs/GaInAs transferred-substrate HBT IC technology. The transferred-substrate HBT IC technology has demonstrated devices with >400 GHz bandwidth (f_{max}) [3], and resistive feedback amplifiers with 50 GHz bandwidth [4]. Here, we present a two stage, DC-coupled differential amplifier. The low frequency gain is 11 dB and the 3-dB bandwidth is greater than 50 GHz. This is the highest bandwidth reported for a broadband differential amplifier.

The device technology used here is similar to our earlier work [3]. The MBE layer structure is similar but with a thinner base layer (400\AA). This improves f_{τ} at the cost of reduced f_{max} . Fig. 1 shows a schematic cross-section of the IC fabrication process. Resistors are made with thin-film NiCr and have $50\Omega/\square$ sheet resistivity. MIM capacitors with 2000\AA SiN as the insulator material are used. The transferred-substrate HBT IC process incorporates a low-capacitance ($\epsilon = 2.7$) microstrip wiring environment with a ground plane and three wiring planes. Efficient heat-sinking is provided through electroplated Au thermal vias. Devices with $0.75\text{ }\mu\text{m}$ wide emitters and $1.8\text{ }\mu\text{m}$ wide collectors were fabricated on this wafer. The common-emitter DC characteristics of the devices are similar to those reported in [3]. Fig. 2 shows the RF characteristics of the devices. The extrapolated f_{max} and f_{τ} are 370 GHz and 160 GHz respectively.

Fig. 3 shows a schematic circuit diagram of the amplifier. The first stage has a emitter-coupled pair with input emitter follower buffers and 50Ω output impedance. The second stage employs transimpedance loading to obtain a $\sim 50\Omega$ interface impedance. Level-shifting diodes are used as shown. Active biasing with transistor current mirrors and a single negative supply is used. The IC consumes 250 mW DC power. Fig. 4 shows a photomicrograph of the amplifier. The chip dimensions are $0.75\text{ mm} \times 0.44\text{ mm}$.

The amplifier performance was measured with a network analyzer to 50 GHz. Only single-ended characteristics (two-port) were measured, with the other ports terminated in 50Ω . Fig. 5 shows the forward gain s_{21} of the amplifier. The low-frequency gain is 11 dB and the 3-dB bandwidth is >50 GHz. The gain ripple at high frequencies is a result of using a 2-port calibration with off-chip terminations of the two unused ports. The in-band gain-flatness (particularly when under AGC) must be improved for application in fiber-optic receivers. Fig. 6 shows the input and output return losses and the reverse isolation of the amplifier.

This work was supported by the ONR under grant N00014-95-1-0688, the AFOSR under grant F4962096-1-0019, a California Hughes Micro no. 8960808 and the DARPA under the MOST program.

[1] M. Yung et. al., *GaAs IC Symp. Tech. Dig.*, 1997, pp. 205-207.

[2] H. Ichino et. al., *J. Lightwave Tech.*, vol. 12, pp. 308-319, 1994.

[3] Q. Lee et. al., *Electron Dev. Lett.*, to appear, March 1998.

[4] B. Agarwal et. al., *Intl' Electron Dev. Meet. Tech. Dig.*, 1997, pp. 743-746.

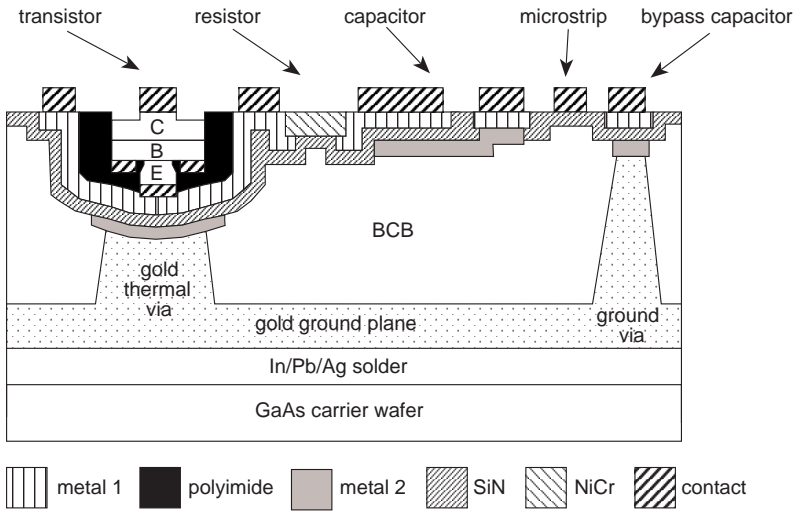

Fig. 1. Schematic cross-section of IC process

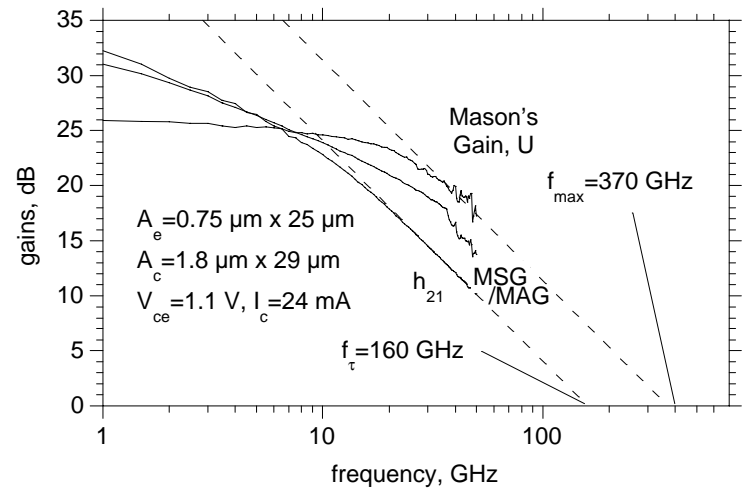

Fig. 2. RF characteristics of device

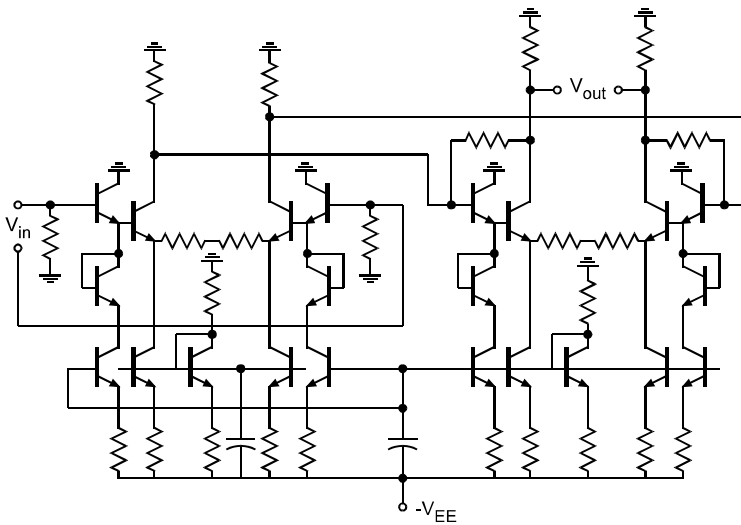

Fig. 3. Schematic circuit diagram of amplifier

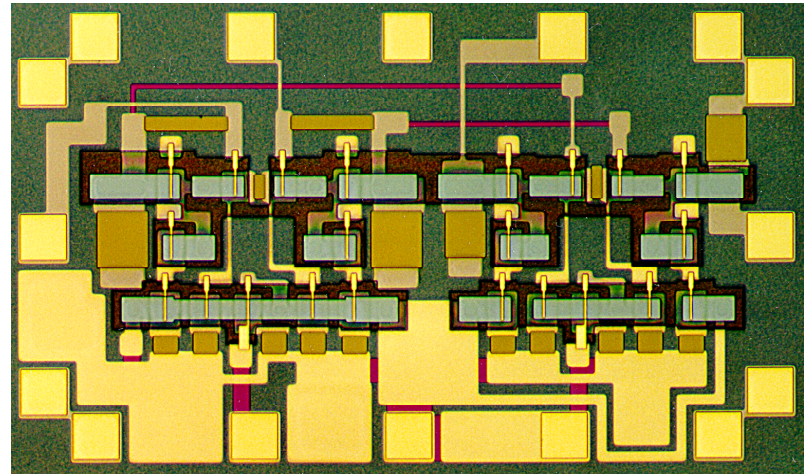

Fig. 4. Photomicrograph of amplifier IC

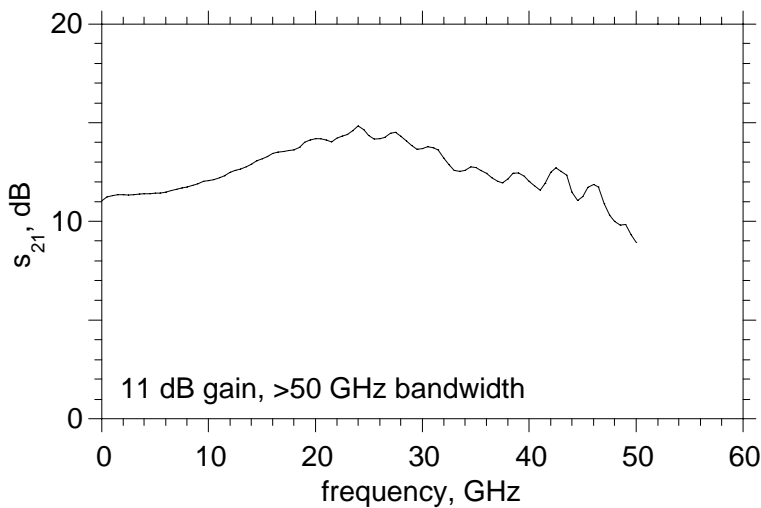

Fig. 5. Forward gain s_{21} of amplifier

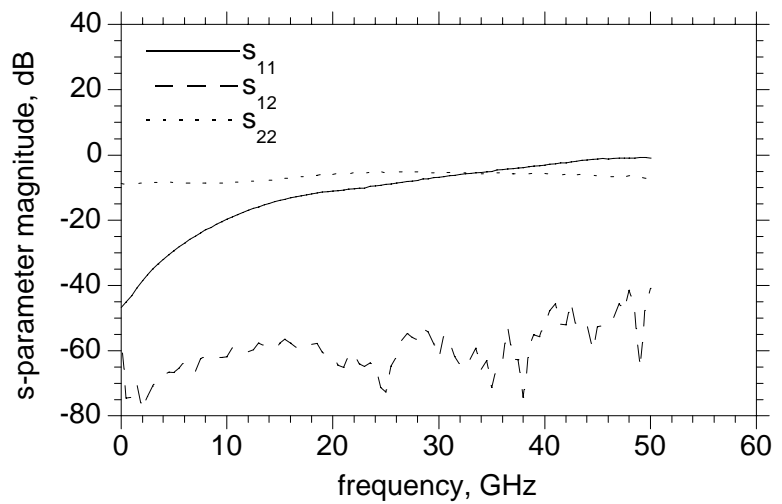

Fig. 6. Return losses and reverse isolation of amplifier