

A Dual Band (10/16 GHz) p-HEMT VCO

Vikas Manan and Stephen I. Long

University of California, Santa Barbara, Dept. of Electrical and Computer Engineering, Eng. Science Bldg., Room 2231F, University of California, Santa Barbara, CA 93106-9560, Phone 805-8933965, Fax 805-8933262

Abstract — We report a 0.15 μm p-HEMT dual frequency VCO. The dual frequencies are achieved using a switched-resonator topology. Large devices can be used for switching, as their parasitic capacitance is absorbed into the resonator. The phase noise at 1 MHz offset was -101 dBc and -92 dBc at 10.6 and 16.3 GHz respectively.

I. INTRODUCTION

In a monolithic LC resonator based VCO implementation, a significant portion of the die area is occupied by the resonator i.e. the inductor and capacitors (varactor). A VCO capable of operating at two different frequencies by using the same resonator tank could reduce the die area and cost. The two frequencies can be arbitrarily chosen depending upon the application.

In this paper, a switched resonator topology which enables the VCO to change frequency between 10 GHz and 16 GHz is presented. Baek et al [1] have implemented an HBT based dual band VCO using resonant mode switching operating above 10 GHz. This method however requires the use of transistors to act as current sources. This introduces another source of $1/f$ noise in the VCO [2] which is already a big issue in HEMT based designs. Dual band VCO's operating at frequencies less than 5 GHz have been reported [3]-[5] using switched resonators, however the switch capacitance was in parallel with the resonator, limiting the channel width and thus the switch resistance. In this design, a series switched resonator topology is used to achieve the band switching. The switch parasitics are absorbed into the resonator enabling the use of large devices as switches. The current source for the VCO is implemented using a resistor to reduce $1/f$ noise upconversion. This is the first such VCO using this topology and the first dual frequency VCO in a p-HEMT process to our knowledge.

II. VCO IMPLEMENTATION

The basic VCO topology used is a cross coupled oscillator. Fig. 1 shows the schematic of the VCO. The DC biasing is not shown in the figure. The inductors in the design are realized using transmission lines. The fine tuning of the frequency is achieved using reverse biased schottky diode with drain-source shorted.

The VCO switches from 10 GHz to 16 GHz when the gate voltage for H1 shown as V_{SWITCH} in Fig. 1 is changed from -1.5 V to 0.4 V. When V_{SWITCH} is below -1.5 V, the channel does not exist for H1 and it is said to be in the off state. When V_{SWITCH} is 0.4 V, the channel is completely formed and the device is said to be in the on

state. The two frequencies are thus switched by turning H1 on and off.

The impedance seen at the drain looks capacitive at the frequencies of interest (10 GHz and 16 GHz) when H1 is off and when the channel exists the impedance looks inductive.

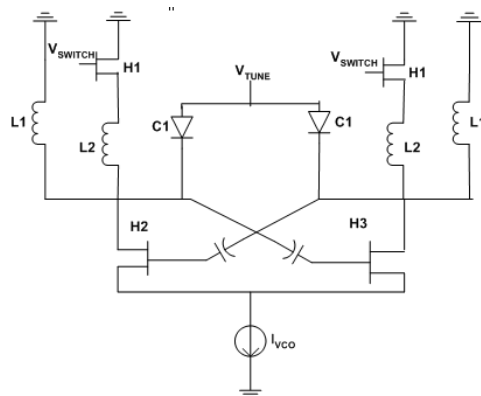

Fig. 1. Dual band VCO

III. RESONATOR

When H1 is off, the effective resonator tank looks as shown in Fig. 2. The Q of the switch, defined as $1/(\omega C_{\text{SWITCH}} R_{\text{OFF}})$, at 10 GHz is 45. The resonator topology in Fig. 2 is responsible for the lower frequency of oscillation (10 GHz). The capacitance C_{SWITCH} , seen at the drain when H1 is off, is given by

$$C_{\text{SWITCH}} = C_{\text{DS}} + \frac{C_{\text{GD}} \times C_{\text{GS}}}{C_{\text{GD}} + C_{\text{GS}}} \quad (1)$$

C_{DS} is the drain source capacitance of H1, C_{GD} and C_{GS} represent the gate-source and gate-drain capacitance of H1. The drain and source resistance of H1 are in series with C_{SWITCH} . This resistance is shown as R_{OFF} in Fig. 2. R_{OFF} for the device used was 1.05 Ω . This resistance degrades the Q of the resonator and therefore the phase noise [6]. Therefore to minimize this resistance, we need to use a large device and this resonator topology permits the use of a large device without compromising on the frequency of oscillation because the device capacitance C_{SWITCH} in the off state is absorbed in the resonator. A very large device however does reduce the tuning range. A simplified expression for the resonant frequency for this resonator topology is given in equation (2).

$$\omega_{\text{LOW}} = \left(\frac{\frac{1}{2C1L1} + \frac{1}{2C1L2} + \frac{1}{2L2C_{\text{SWITCH}}}}{\sqrt{\frac{-4C1C_{\text{SWITCH}}L1L2 + (-C1L1 - C_{\text{SWITCH}}L1 - C_{\text{SWITCH}}L2)^2}{2C1C_{\text{SWITCH}}L1L2}}} \right)^{1/2} \quad (2)$$

The above expression does not take layout parasitics or transistor H2, H3 parasitics into account.

When H1 is turned on, the effective resonator topology is shown in Fig. 3. The drain resistance, source resistance and the channel resistance add in series with L2. This resistance is shown as R_{ON} in Fig. 3. R_{ON} for the device used was 1.9Ω . The approximate resonance frequency for this topology is given by

$$\omega_{\text{HIGH}} = \frac{\sqrt{L1 + L2 + L_{\text{ON}}}}{\sqrt{L1 \times (L2 + L_{\text{ON}}) \times C1}} \quad (3)$$

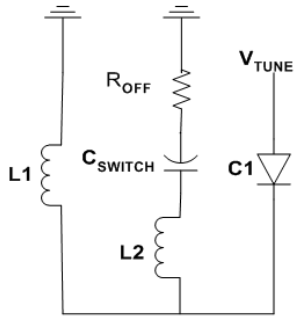

Fig. 2. Resonator when H1 is off

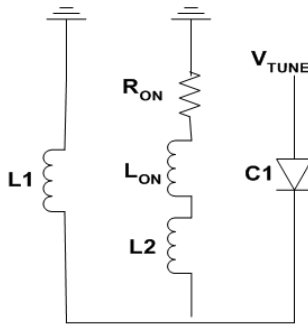

Fig. 3. Resonator when H1 is on

IV. EXPERIMENTAL RESULTS

The VCO was fabricated using a $0.15\ \mu\text{m}$ p-HEMT commercial GaAs process. The circuit was wafer probe tested. In order to minimize the Q degradation, the VCO output was taken through a buffer.

The phase noise was measured using the Agilent E4440A spectrum analyzer, and the phase noise at 1 MHz offset from the 10.6 GHz carrier was $-101\ \text{dBc/Hz}$ and $-92\ \text{dBc/Hz}$ for the 16.3 GHz carrier. The VDD was 2.5 V, and the current consumption at 10.6 GHz was 6 mA and 21 mA at 16.3 GHz.

A larger current was needed for operating the VCO at higher frequency because the parallel resistance R_p seen

across the tank at the higher resonant frequency was lower due to a poorer tank Q. A larger current compensates for this lower R_p in order to get the VCO loop gain > 1 at startup.

A widely used figure of merit (FOM) for VCO performance is defined as

$$\text{FOM} = L(f_{\text{offset}}) - 20\log\left(\frac{f_o}{f_{\text{offset}}}\right) + 10\log\left(\frac{P_{\text{DC}}}{1\text{mW}}\right) \quad (4)$$

Here, $L(f_{\text{offset}})$ is the measured phase noise from the oscillation frequency f_o . P_{DC} is the DC power consumption of the VCO. The FOM at 1 MHz offset was $-159\ \text{dBc/Hz}$ at 16.46 GHz and $-170\ \text{dBc/Hz}$ at 10.7 GHz.

The frequencies could be fine tuned using the varactor voltage V_{TUNE} . The varactor is realized using a reverse biased schottky diode with drain-source shorted. The capacitance variation of the varactor with voltage is shown in Fig. 4. This variation plotted in Fig. 4 is with the drain-source grounded. However in the VCO implementation the DC voltage at the drain-source node is VDD. We notice two abrupt changes in the capacitance with voltage (Fig. 4). The first abrupt change is around $-1.2\ \text{V}$. This is the voltage at which the channel begins to exist and causes an increase in capacitance. The next abrupt change takes place close to $0.4\ \text{V}$. This is because of an increase in schottky diode depletion capacitance when the diode is close to being forward biased. We operate in the region much below the $0\ \text{V}$ range as when the diode gets forward biased the Q of the tank drops drastically and leads to poor phase noise. The frequency could be tuned from 16.05 GHz to 16.3 GHz when V_{TUNE} was changed from $-1.6\ \text{V}$ to $0.6\ \text{V}$ and from 10.3 GHz to 10.63 GHz when V_{TUNE} was changed from $-1.2\ \text{V}$ to $1.2\ \text{V}$.

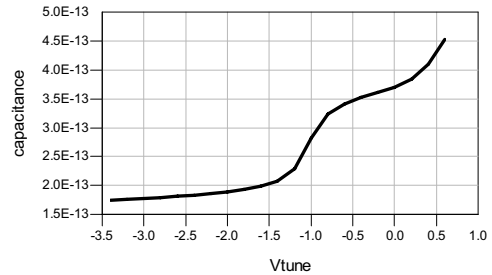

Fig. 4 Capacitance variation of the varactor

The plots of the measured phase noise at 10.60 GHz and 16.3 GHz are shown in Fig. 5 and Fig. 6 respectively. The slope from 100 kHz to 1 MHz is more than 20 dB/decade indicating the contribution of $1/f$ noise. $1/f$ noise upconversion is one of the biggest challenges in designing HEMT based oscillators. The authors are currently investigating circuit modifications to reduce this upconversion of $1/f$ noise. The chip micrograph is shown in Fig. 7. A summary of the VCO performance is given in Table 1.

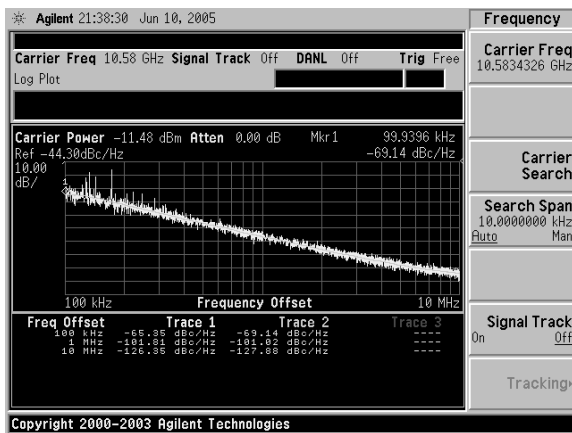

Fig. 5 Measured Phase Noise 10.60 GHz

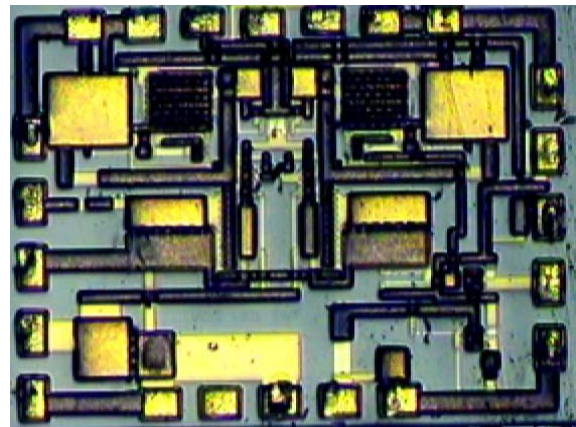

Fig.7 Chip Micrograph

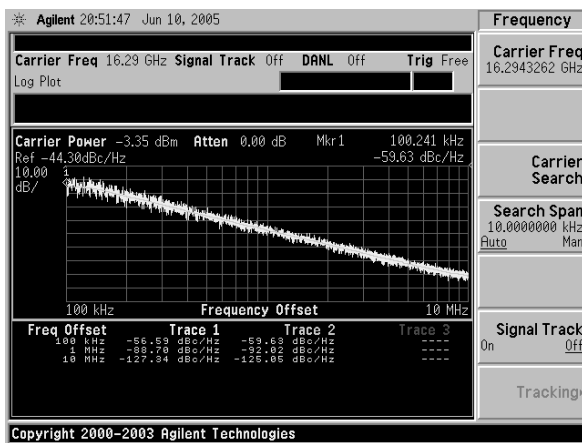

Fig. 6. Measured phase noise at 16.3 GHz

V. CONCLUSION

A dual band (10 GHz and 16 GHz) VCO implemented using a 0.15 μm GaAs process is presented in this paper. This is the first demonstration of a dual band VCO in the p-HEMT process in the author's knowledge. The dual band operation is achieved by using a switched resonator topology. This resonator topology absorbs the switch capacitance into the resonator, thus allowing the use of large switches to minimize the Q degradation of the resonator tank due to the switch.

ACKNOWLEDGEMENT

The authors would like to thank iTerra Communications for their support in fabrication of the circuit and to the UC Discovery Program. The authors would also like to thank Prof. Robert York and Chris Sanabria for their support in testing and P.W. Lai for helpful discussions.

REFERENCES

- [1] Donghyun Baek, Jeonggeun Kim and Songcheol Hong "A Dual-Band (13/22-GHz) VCO Based on Resonant Mode Switching," IEEE Microwave and Wireless Components Letters, Vol. 13, No. 10, October 2003.
- [2] Ali Hajimiri and T. Lee, "Design Issues in CMOS Differential LC oscillators," IEEE Journal of Solid-State Circuits, Vol. 34, No. 5, May 1999
- [3] Seong-Mo Yim and Kenneth K.O, "Demonstration of a switched Resonator Concept in a Dual Band Monolithic CMOS LC-Tuned VCO," IEEE 2001 Custom Integrated Conference.
- [4] Zhenbiao Li and Kenneth K.O "A 1-V Low Phase Noise Multi-Band CMOS Voltage Controlled Oscillator with switched Inductors and Capacitors," 2004 RFIC Symposium, pp. 467-470, 2004.
- [5] Zhenbiao Li and Kenneth K.O "A 900MHz 1.5-V CMOS Voltage Controlled Oscillator using switched resonators with a wide tuning range," IEEE Microwave and wireless component Letters, Vol. 13, No. 4, April 2003.
- [6] D. B. Leeson, "A simple model of feedback oscillator noise spectrum," Proc. IEEE, vol. 54, pp 329-330, Feb 1966.

	Frequency 1	Frequency 2
V_{SWITCH}	-1.5 V	0.4 V
V_{TUNE}	-1.2 V to 1.2 V	-1.6 V to 0.6 V
Tuning Range	10.33 GHz to 10.63 GHz	16.05 GHz to 16.3GHz
Frequency at which Phase Noise measured	10.6 GHz	16.3 GHz
Phase Noise @ 1MHz offset	-101 dBc/Hz	-92 dBc/Hz
VDD	2.5 V	2.5 V
ID	6 mA	21 mA
FOM @ 1MHz offset	-170 dBc/Hz	-159 dBc/Hz

TABLE I Summary of VCO Performance