

Dynamically reconfigurable optical packet switch (DROPS)

Chi-Heng Huang, Hsu-Feng Chou and John E. Bowers

Department of Electrical and Computer Engineering, University of California, Santa Barbara, CA 93106, USA
Hsu-Feng.Chou@ieee.org

Farzam Toudeh-Fallah, and Russ Gyurek

Cisco Systems, Inc., San Jose, CA 95134, USA

Abstract: A novel Dynamically Reconfigurable Optical Packet Switch (DROPS) that combines both spectral and spatial switching capabilities is proposed and experimentally demonstrated for the first time. Compared with an Arrayed Waveguide Grating Router (AWGR), the added spatial switching capability provided by the microelectromechanical systems (MEMS) enables dynamically reconfigurable routing that is not possible with an AWGR alone. This methodology has several advantages over an AWGR including scalability, additional degrees of freedom in routing a packet from an ingress port to an egress port and more flexibility in path or line card recovery. The experimental demonstration implemented with 10-Gb/s packets shows that the added spatial switching does not degrade the bit-error-rate performance, indicating the promising potential of DROPS as a versatile and ultra-high capacity switch for optical packet-switched networks.

©2006 Optical Society of America

OCIS codes: (060.2330) Fiber optics communications; (060.4250) Networks

References and Links

1. W. Wang, L. G. Rau, and D. J. Blumenthal, "160 Gb/s Variable Length Packet/10 Gb/s-Label All-Optical Label Switching With Wavelength Conversion and Unicast/Multicast Operation," *J. Lightwave Technol.* **23**, 211-218 (2005).
 2. A. Carena, M. D. Vaughn, R. Gaudino, M. Shell, and D. J. Blumenthal, "OPERA: An Optical Packet Experimental Routing Architecture with Label Swapping Capability," *J. Lightwave Technol.* **16**, 2135-2145 (1998).
 3. H. N. Poulsen, S. Rangarajan, M. L. Masanovic, V. Lal, and D. J. Blumenthal, "Performance of a Label Erase and Wavelength Switching Sub-System for Layer-3 All-Optical Label Switching Using a Two Stage InP Wavelength Converter," in *Technical Digest of Optical Fiber Communication Conference (OFC '05)*, Paper OTuC2.
 4. X. Zheng, V. Kaman, S. Yuan, Y. Xu, O. Jerphagnon, A. Keating, R. C. Anderson, H. N. Poulsen, B. Liu, J. R. Sechrist, C. Pularla, R. Helkey, D. J. Blumenthal, and J. E. Bowers, "Three-Dimensional MEMS Photonics Cross-Connect Switch Design and Performance," *IEEE J. Sel. Top. Quantum Electron.* **9**, 571-578 (2003).
 5. J. Kim, C. J. Nuzman, B. Kumar, D. F. Lieuw, J. S. Kraus, A. Weiss, C. P. Lichtenwalner, A. R. Papazian, R. E. Frahm, N. R. Basavanahally, D. A. Ramsey, V. A. Aksyuk, F. Pardo, M. E. Simon, V. Lifton, H. B. Chan, M. Haueis, A. Gasparyan, H. R. Shea, S. Arney, C. A. Bolle, P. R. Kolodner, R. Ryf, D. T. Neilson, J. V. Gates, "1100 × 1100 Port MEMS-Based Optical Crossconnect With 4-dB Maximum Loss," *IEEE Photon. Technol. Lett.* **15**, 1537-1539 (2003).
 6. S. Kamei, M. Ishii, M. Itoh, T. Shibata, Y. Inoue, and T. Kitagawa, "64 × 64-channel uniform-loss and cyclic-frequency arrayed-waveguide grating router module," *Electron. Lett.* **39**, 83-84 (2003).
 7. Personal communication with Dr. Roger Helkey of Calient Networks, Goleta, CA, USA
 8. P.M. Hagelin, U. Krishnamoorthy, C. M. Arft, J. P. Heritage, O. Solgaard, "Scalable Fiber Optic Switch Using Micromachined Mirrors," in *Proceedings of the 1999 International Conference on Solid-State Sensors and Actuators (Transducer '99)*, pp. 782-785
 9. C. Nuzman, J. Leuthold, R. Ryf, S. Chandrasekhar, C. R. Giles, and D. T. Neilson, "Design and Implementation of Wavelength-Flexible Network Nodes," *J. Lightwave Technol.* **21**, 648-663 (2003).
-

1. Introduction

All-optical packet switches are promising solutions when line speeds become high and very large router capacity is required. Optical-electrical-optical (O-E-O) conversions of the payload needed in a conventional router are not required in an all-optical packet switch, making it easier to scale the capacity efficiently and increase the bit-rates beyond what can be processed by electronics [1]. All-optical packet switches using wavelength converters before and after an Arrayed Waveguide Grating (AWG) have been proposed [2], where the routing is determined by the wavelength of the input wavelength converters and the routing properties of the AWG. The switching time is mainly determined by how fast the laser wavelength in the wavelength converter can be tuned and down to a few ns tuning time has been reported [3]. However, the routing property of the AWG-based router (AWGR) is fixed at the time of fabrication, which is a constraint on network management.

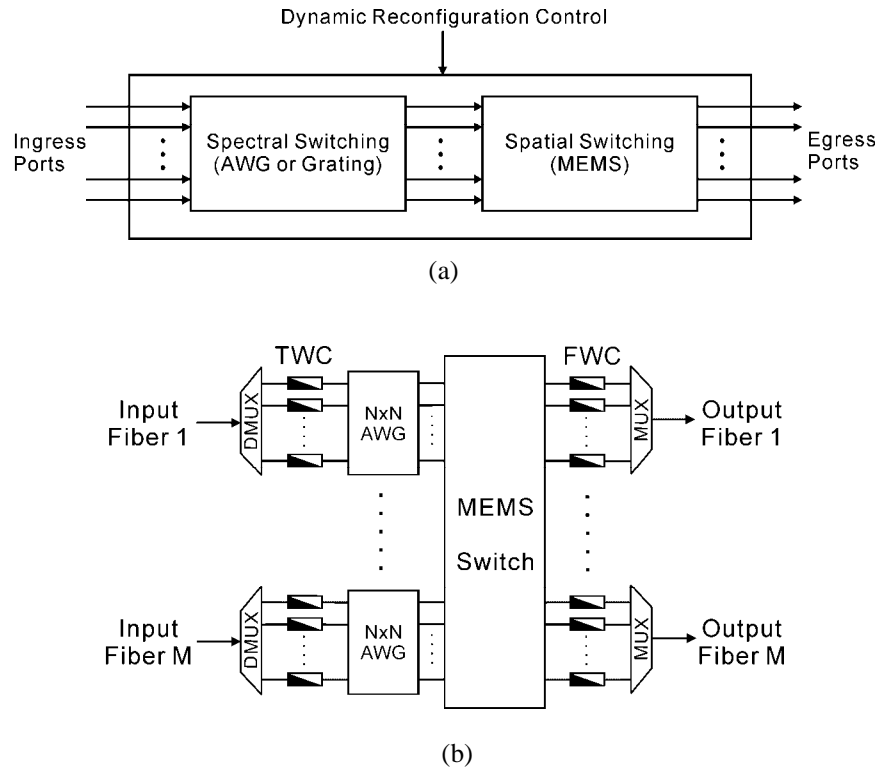

Fig. 1. (a) Concept of Dynamically Reconfigurable Optical Packet Switch (DROPS); (b) an example application of DROPS. TWC / FWC: tunable / fixed wavelength converter.

In this paper, we propose that by combining spectral and spatial switching methodologies, the routing property can be dynamically reconfigured in order to provide more flexibility in network management. This new combination is termed Dynamically Reconfigurable Optical Packet Switch (DROPS) and is schematically illustrated in Fig. 1(a). To scale the port count to meaningful numbers, spatial switches based on the microelectromechanical systems (MEMS) are the ideal choice for DROPS [4]. MEMS-based spatial switch has been demonstrated to be as large as 1100×1100 [5], which is much larger than the largest AWG reported to date (64×64) [6]. This implies that many wavelength-based switches (for example, AWG's) can be interconnected as needed by a MEMS switch in order to provide higher routing capacity

compared to a single AWGR. Fig. 1(b) shows a possible implementation of DROPS as a switching node with tunable and fixed wavelength converters. The scale of a MEMS switch is limited by the number of mirrors fabricated on a die. However, the diffraction limit is even larger, and multiple dies can be stitched together, making the upper limit extremely high (over 5000×5000 [7]). Aside from AWG, a planar technology, the spectral switch can be constructed with non-planar technologies such as a free-space grating, indicating that even more compact and high-capacity integration with the MEMS-based spatial switch is possible [8]. When there is need to modify the wavelength of each packet in a packet by packet basis, high-speed wavelength tuning of wavelength converters can be achieved with the use of fast tunable lasers.

DROPS has many advantages over the AWGR-based approach (spectral switching only) in optical packet switching applications:

- 1) An AWGR based packet switch has a fixed mapping from ingress to egress port in which specific wavelengths in each ingress port would exit from specific egress ports based on a permutation mechanism (refer to Table 1 for an 8×8 example). In contrast, a DROPS-based switch has the potential of routing any wavelength from any ingress port to any egress port (Table 2). This is not the case in an AWGR-based mechanism (Table 1).

Table 1. Ingress-egress mapping of wavelengths in an 8×8 AWGR mechanism

		AWGR output port							
		λ_1	λ_2	λ_3	λ_4	λ_5	λ_6	λ_7	λ_8
AWGR input port	1	1	8	7	6	5	4	3	2
	2	2	1	8	7	6	5	4	3
	3	3	2	1	8	7	6	5	4
	4	4	3	2	1	8	7	6	5
	5	5	4	3	2	1	8	7	6
	6	6	5	4	3	2	1	8	7
	7	7	6	5	4	3	2	1	8
	8	8	7	6	5	4	3	2	1

Table 2. Ingress-egress mapping of wavelengths in an 8×8 DROPS mechanism

		DROPS output port							
		λ_1	λ_2	λ_3	λ_4	λ_5	λ_6	λ_7	λ_8
DROPS input port	1	1,2,3,...8	1,2,3,...8	1,2,3,...8	1,2,3,...8	1,2,3,...8	1,2,3,...8	1,2,3,...8	1,2,3,...8
	2	1,2,3,...8	1,2,3,...8	1,2,3,...8	1,2,3,...8	1,2,3,...8	1,2,3,...8	1,2,3,...8	1,2,3,...8
	3	1,2,3,...8	1,2,3,...8	1,2,3,...8	1,2,3,...8	1,2,3,...8	1,2,3,...8	1,2,3,...8	1,2,3,...8
	4	1,2,3,...8	1,2,3,...8	1,2,3,...8	1,2,3,...8	1,2,3,...8	1,2,3,...8	1,2,3,...8	1,2,3,...8
	5	1,2,3,...8	1,2,3,...8	1,2,3,...8	1,2,3,...8	1,2,3,...8	1,2,3,...8	1,2,3,...8	1,2,3,...8
	6	1,2,3,...8	1,2,3,...8	1,2,3,...8	1,2,3,...8	1,2,3,...8	1,2,3,...8	1,2,3,...8	1,2,3,...8
	7	1,2,3,...8	1,2,3,...8	1,2,3,...8	1,2,3,...8	1,2,3,...8	1,2,3,...8	1,2,3,...8	1,2,3,...8
	8	1,2,3,...8	1,2,3,...8	1,2,3,...8	1,2,3,...8	1,2,3,...8	1,2,3,...8	1,2,3,...8	1,2,3,...8

- 2) The combination of spectral and spatial degrees of freedom in the DROPS mechanism provides far more flexibility in controlling the routing of the packet in a switch fabric as compared to only one degree of freedom (wavelength control) in an AWGR mechanism.

- 3) The DROPS mechanism provides a higher degree of scalability compared to the AWGR mechanism for a packet switching application due to the potential scalability of the number of ingress/egress ports in MEMS, which is far greater than what is available via AWGRs.
- 4) The dynamical reconfigurability of the DROPS mechanism would allow fast recovery in milliseconds from a line card or path failure without any need for modifying the packet wavelength, which is not the option in AWGR-based methods. This provides more flexibility in fast recovery scenarios.

On the other hand, DROPS also has many advantages over a single-stage MEMS switch (spatial switching only) in terms of optical packet switching applications:

- 1) A single-stage MEMS switch is not applicable to packet switching applications due to its slow switching time (on the order of milliseconds). However, a combination of spectral and spatial switching mechanism (DROPS) would allow fast switching of packets based on their wavelengths which is done by modifying the wavelengths of each packet through a fast tunable laser (on the order of nanoseconds).
- 2) A single-stage MEMS switch only provides switching capabilities based on the spatial property of the input packets, which in many scenarios is not enough. However, combining a MEMS switch with a spectral switch would allow the packets to be switched not only based on their ingress ports, but also their specific wavelengths per packet, which is crucial in practical packet switching / routing architectures.
- 3) Even if a MEMS switch can be switched at high / comparable speed, the spectral switch in DROPS cannot be simply replaced with such spatial switch because in addition to providing a fast switching mechanism, the spectral switch also provides another dimension to packet switching such that the combination of the spectral and spatial switching would provide the capability of switching a packet based on both input port and the wavelength of each packet.

There might have been some previous works on combining AWG and MEMS [9] but the applications have been in the context of wavelength routing such that AWG is used for wavelength demultiplexing followed by a MEMS switch for individual wavelength routing. The proposed DROPS concept is the first suggestion on using a combination of spectral and spatial components in the context of *packet switching*.

2. Experiment and results

To verify the feasibility of the proposed DROPS concept, an experiment was done to assess the impact of adding the spatial MEMS switch to a spectral AWG switch. The experimental setup is shown in Fig. 2. The pattern generator generates continuous signals at 10 Gb/s with non-return-to-zero $2^{31}-1$ pseudorandom bit sequence. The transmitter (Tx) consists of a continuous wave (CW) laser operating at 1550 nm with 7-dBm output power and a LiNbO₃ modulator. Another LiNbO₃ modulator is used as a switch to gate the signal into packets. The gating signal is generated by a PC-based arbitrary function generator. Two sets of packets with different lengths, 120 ns and 160 ns, are generated interlaced. The guard time between the two packets is 140 ns.

We use an O-E-O type of wavelength converter to perform spectral routing with the AWG, although all-optical wavelength converters can also be used to operate at higher bit-rates [1]. The O-E-O wavelength converter consists of a PIN photodiode (PD), a 10-Gb/s amplifier, a Sampled-Grating Distributed Bragg Reflector (SGDBR) laser, and a LiNbO₃ external modulator. The output wavelength of the SGDBR laser is fast tuned by a high-speed voltage-to-current converter, which converts the tuning signal generated by the arbitrary function generator from voltage signal to current signal. The timing of the tuning signal is adjusted so that the wavelengths of the 160 ns and 120 ns packets are converted to 1546.8 nm

and 1552.2 nm, respectively. These packets with different wavelengths are routed to two separate output ports of the AWG and then fed into two different input ports of the MEMS-based spatial switch. The AWG is 1×40 with 100 GHz channel spacing and worst case insertion loss of 6.9 dB.

The MEMS switch is 256×256 with worst case insertion loss of 3.0 dB [4]. With the added MEMS spatial switch, the packets can be rerouted to any output port desired. At the outputs of DROPS, an error detector is connected through a pre-amplified receiver to analyze the routed signal. Since the received signals are packets, a gating signal is necessary to perform the bit-error-rate (BER) measurement in the burst mode. Gating signals of length 120 ns and 80 ns are aligned respectively at the center of the 160 ns and the 120 ns packets in the BER measurements.

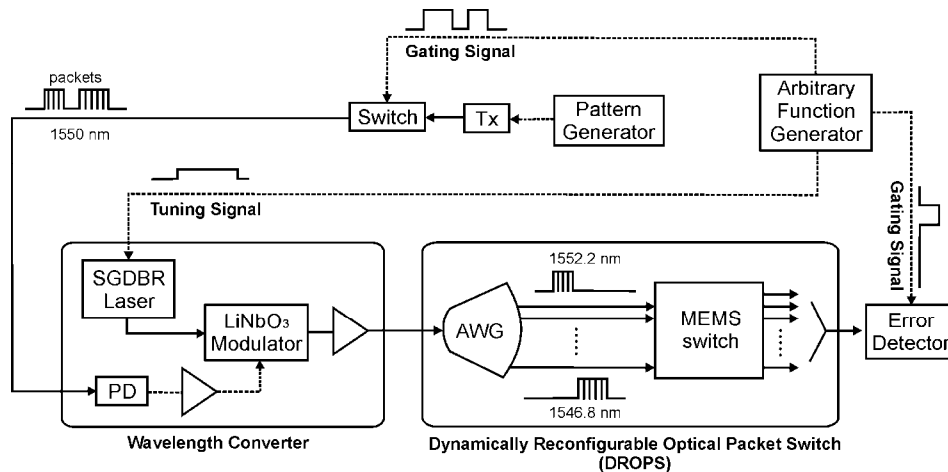

Fig. 2. Experimental Setup. Solid link: optical; dashed link: electrical.

The scope traces of the routed packets are shown in Fig. 3. Two sets of packets at 1550 nm with different durations are generated. The longer packet is 160 ns in length and the shorter packet is 120 ns in length with 140 ns guard time between each packet. These packets are fed into the wavelength converter and the output wavelengths can be switched to any wavelength in the C-band by changing the level of the tuning signal. The wavelengths 1546.8 nm and 1552.2 nm are chosen for the long packet and short packet, respectively, which are roughly the center wavelengths of ch-23 and ch-30 of the AWG.

After passing through the AWG, the long packet goes to output port 23 of the AWG while the short packet goes to output port 30, which are connected to input port 1 and input port 2 of the MEMS switch. At state 1, the input port 1 and input port 2 of the MEMS switch are connected to output port 1 and output port 2, respectively, so that the long packet is switched to output port 1 while the short packet is switched to output port 2. To demonstrate the reconfigurability of this system, the configuration of the MEMS switch can be changed to state 2, which makes input port 1 connected to output port 2 and input port 2 to output port 1. As a result, the long packet exits from output port 2 and the short packet exits from output port 1.

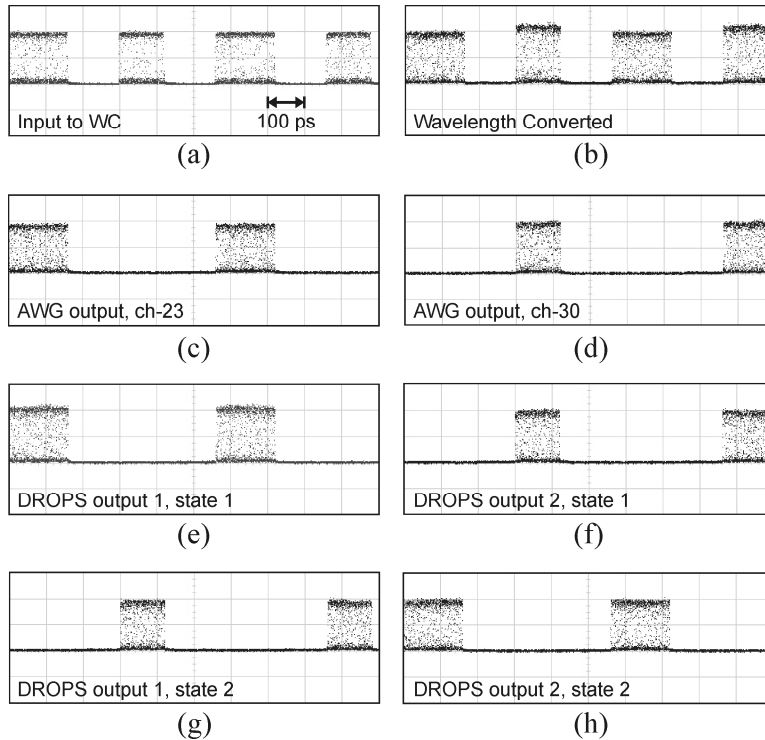

Fig. 3. Scope traces of packets at (a) the input of the wavelength converter (1550 nm); (b) the output of the wavelength converter (1546.8 nm and 1555.2 nm); (c) ch-23 output of AWG (1546.8 nm); (d) ch-30 output of AWG (1552.2 nm); (e) output port 1 of DROPS in state 1; (f) output port 2 of DROPS in state 1; (g) output port 1 of DROPS in state 2; (h) output port 2 of DROPS in state 2

The BER of the packets was measured to quantify the performance. Six sets of BER data are measured for both long packets and short packets: (1) back-to-back packets at 1550 nm, (2) wavelength converted packets with no wavelength tuning, (3) wavelength converted packets with fast tuning between two different wavelengths, (4) wavelength routed packets after AWG, (5) routed packets in state 1, and (6) routed packets in state 2. To identify the power penalty of each stage, the power difference due to gain variation of the pre-amplified receiver and the change of duty-cycle among various stages must be calibrated. First, the Erbium-doped fiber amplifier (EDFA) inside the pre-amplified receiver has a 0.55 dB higher gain at 1546.8 nm (long packet) and a 0.4 dB lower gain at 1552.2 nm (short packet), compared to that at 1550 nm (back-to-back). Secondly, the long packets and the short packets are separated after passing through the AWG, which decreases the duty-cycle of the signal and results in a smaller average power. For a proper comparison, these variations are offset individually by scaling the received power to match the back-to-back condition at 1550 nm.

The adjusted BER curves are shown in Fig. 4(a) and Fig. 4(b). From these two figures, it can be inferred that the power penalty mainly comes from the particular O-E-O wavelength converter used in the experiment and no extra penalty is added by the AWG and the MEMS switch. The power penalty is 3.0 dB for the long packets and 2.7 dB for the short packets, which is caused by the pattern dependence of the electrical amplifier used in the O-E-O wavelength converter. No error floors are observed in either case.

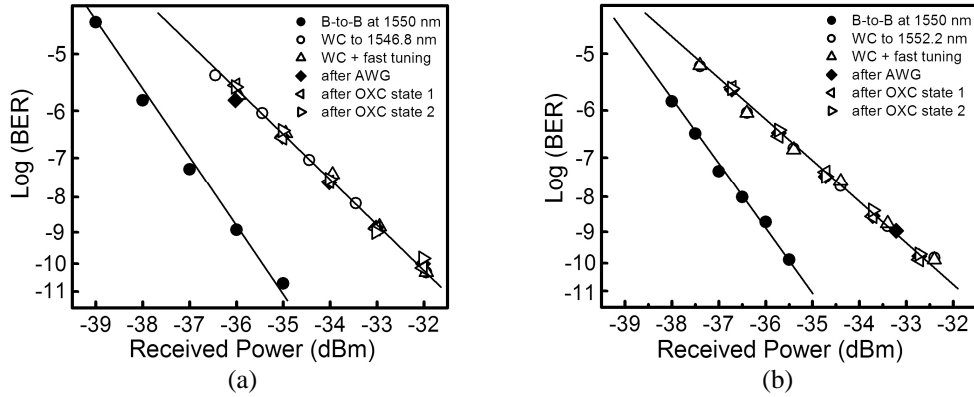

Fig. 4. Calibrated bit-error-rate results for (a) long packets; (b) short packets.

3. Conclusion

A novel all-optical switch, DROPS, which is capable of both spectral and spatial routing of optical packets has been proposed and experimentally demonstrated. The spatial switch, preferably MEMS-based, enables dynamic reconfiguration of routing properties and provides an extra degree of freedom in network management. The experimental results with 10-Gb/s packets show that the added spatial switching does not degrade the BER performance.

Acknowledgments

This work was supported by Cisco Systems, Inc. The authors would like to thank Henrik N. Poulsen for helpful discussions on the experimental setup and Matthew N. Sysak for providing the SGDBR laser.