

All-Optical Payload Envelope Detection for Packets with 40 Gbps Payloads and 10 Gbps Labels

Brian R. Koch, Zhaoyang Hu, John E. Bowers, Daniel J. Blumenthal

Department of Electrical and Computer Engineering, University of California, Santa Barbara, California, 93106, USA, koch@ece.ucsb.edu

Abstract We demonstrate an all-optical technology to detect payload envelopes of variable length optical packets consisting of 40Gbps RZ payloads and 10Gbps NRZ labels. This envelope signal has 300ps rise time and 30ps timing jitter.

Introduction

Optical label swapping is under investigation for packet switching in lower power data switched networks (1, 2). In optical label swapping information is carried in packets. At nodes, labels must be recovered, erased, and re-written while keeping the packets' contents in the optical domain. Erasing and re-writing labels requires knowledge of the temporal location of the payload with a high degree of accuracy. An optoelectronic payload envelope detection (PED) circuit has previously been demonstrated with several nanoseconds rise time and approximately 150ps timing jitter (3, 4). However, all-optical generation of a PED signal is desirable for all-optical networks.

In this paper, we present the first all-optical PED signal generation, demonstrating rise time around 300ps (12 bits) and RMS jitter near 30ps (~1 bit). These facts indicate that very short guard bands can be used in this label swapping method. The input power dynamic range of the all-optical PED is over 10 dB. The use of only optical semiconductor devices employed in this PED technique provides a way to monolithically integrate PED circuits.

Operation Principle and Experimental Setup

The input packet stream consists of 10 Gbps NRZ labels 128 bits long followed by 40 Gbps RZ payloads. The main components of the PED setup are an optical Q filter, an optical envelope detector, and an optical inverter shown in Figure 1a.

1) Optical Q filter: a low Q factor is desired for the optical Q filter in order to achieve fast rise/fall time. In our experiment, an SGDBR laser biased at transparency is employed as the Q filter.

2) Optical envelope detector: requires certain threshold decision level. A laser diode (LD) biased above threshold works as an envelope detector by suppressing its lasing or not with optical input.

3) Optical inverter: the inverted payload envelope output from the envelope detector is inverted again based on cross gain modulation (XGM) in a semiconductor optical amplifier (SOA).

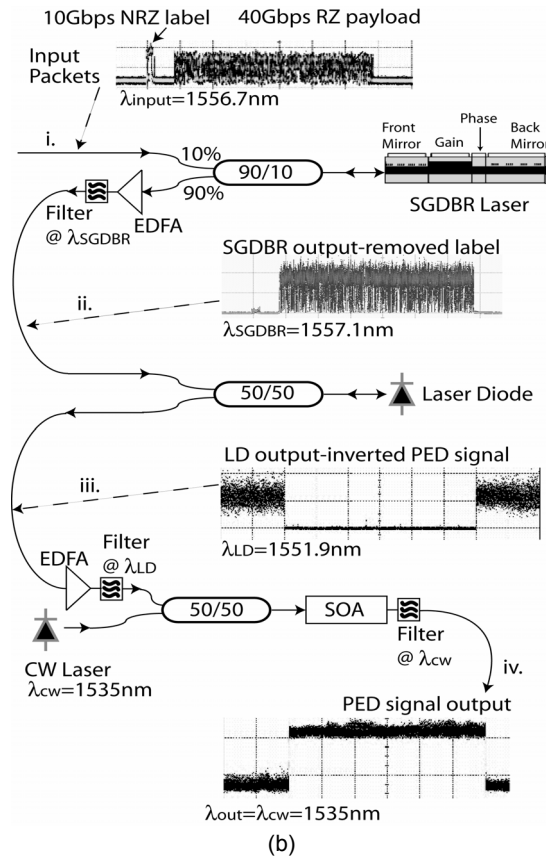
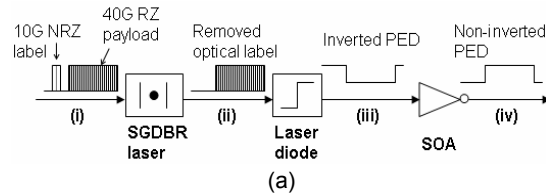

Figure 1: (a) All-optical payload envelope detection configuration (b) experimental setup with oscilloscope traces at various points in the process (i-iv).

The details of the SGDBR laser used in our experiment were reported in (5). It is biased at transparency and its mirrors and phase section are tuned such that the laser's effective length corresponds to a 40 GHz resonant frequency. Due to enhanced resonance at 40 GHz, the SGDBR laser lases or not depending on the input optical packets

shown as the inset picture (i) in Figure 1(b): lasing when the 40 Gbps RZ payloads are present, but not when the 10 Gbps NRZ labels enter. Therefore the laser acts as an optical Q filter with a relatively low Q factor, resulting in fast rise/fall times. The SGDBR must also be tuned such that the input wavelength is within the range of the mirror reflectivity peaks. Since the SGDBR is finely tuneable in wavelength over 70nm this is not a problem and even implies that the input wavelength range could be very high. Since the SGDBR is a quantum well device, the input polarization must be controlled.

The output of the SGDBR laser with removed optical label as shown in the inset picture (ii) in Figure 1(b) goes to a LD. The LD is biased above threshold at a level such that the SGDBR laser output can suppress its gain or not: the payload corresponding part in the SGDBR laser output can turn off the LD. Thus the output of the LD is an inverted payload envelope signal shown as the inset picture (iii) in Figure 1(b). Furthermore, the inverted PED signal is inverted again to obtain a non-inverted PED signal at another wavelength by using XGM in a SOA, as shown in the inset picture (iv) in Figure 1(b). Thus a PED signal with any desired wavelength can be achieved.

Results

We used a repeating 60 packet long packet stream approximating Internet traffic (IMIX) to test the PED setup: for every 12 packets there are 7x40 byte payloads (8ns), 4x570 byte payloads (114ns), and 1x1500 byte payload (300ns). As shown in Figure 2, the PED signal is generated for variable length payloads with labels. Using an oscilloscope, we also measured the duration of the PED signals and found that they are exactly equal to the incoming payload duration, shown as inset pictures in Figure 2. These results indicate that this PED signal can be used to directly erase labels via an all-optical gate such as a SOA-MZI while the payloads pass through. Alternatively, the inverted PED signal directly from the LD could be used to perform XGM in an SOA to erase the labels as performed in (4).

To test the input power dynamic range of the system, we measured the rise time and RMS jitter for various input powers to the SGDBR. Results are shown in Figure 3. Typical results are a rise time of 300ps, and RMS jitter of 30ps. The input signal rise time is instantaneous and its jitter is less than 1ps. The PED signal amplitude is around 260 μ W and the fall time of the signal is around 450ps for this dynamic range.

Conclusions

We have demonstrated an all-optical payload envelope detection circuit to locate the precise temporal location of optical payloads. The operation is

based on bit-rate filtering using a resonant laser biased at transparency to remove labels, followed by a gain suppressed laser to create an envelope of the payload only. The payload envelope signal has a rise time of 300ps, fall time of 450ps, and RMS jitter in the rising and falling edges near 30ps. The PED signal can be used to directly erase labels and to time the insertion of new labels.

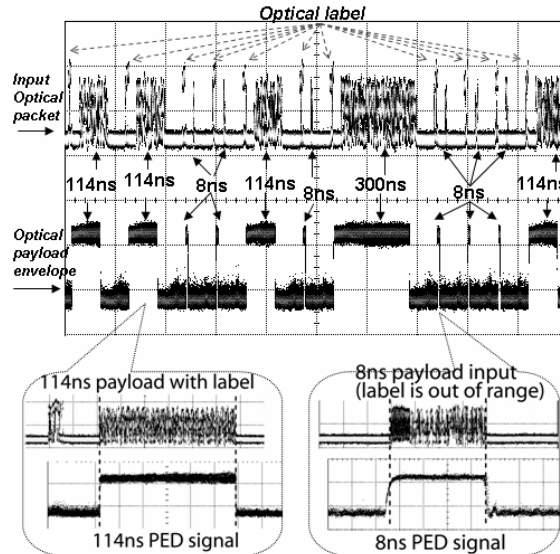

Figure 2: Input optical packets with labels and 8ns, 114ns, and 300ns long payloads (upper) and the corresponding PED signals (lower). Inset: zoom-in for 114ns and 8ns PED signals.

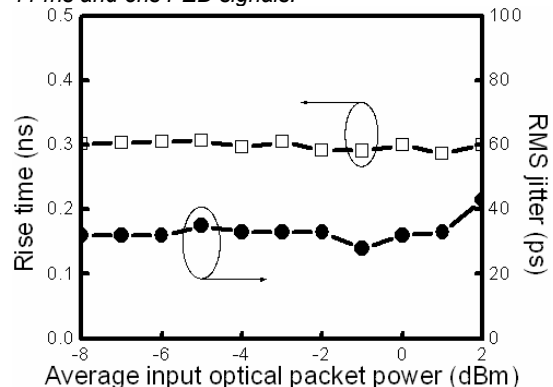

Figure 3: Rise time and RMS jitter of the PED rising edge, versus average input optical packet power (measured after the 90/10 coupler).

Acknowledgements

Thanks to Agility for providing the SGDBR laser and to DARPA LASOR for providing funding.

References

- 1 Blumenthal et al., IEEE JLT, vol. 18 (2000), p. 2058.
- 2 Viswanathan et al., IEEE Comm. Mag., Vol. 36 (1998), p.165.
- 3 Hu et al., IEEE PTL, vol. 17 (2005), p.1537.
- 4 Koch et al., OFC Conference 2006, paper OWL7.
- 5 Johansson et al., IEEE PTL, vol. 17 (2005), p. 285.