

REFs: Class Notes Set #6 and 7; Stability and Gain Tutorial and ADS files.

1. The amplifier manufacturer, stikit2u.com, claims that their model DOA-1 LNA has an IIP3 of 0 dBm under two-tone measurement conditions ($f_1 = 999.9$ MHz; $f_2 = 1000.1$ MHz). The gain of the amplifier is 10 dB, and its noise figure is 3 dB. Given the shady reputation of the manufacturer, you decide to perform a measurement to verify their claim.

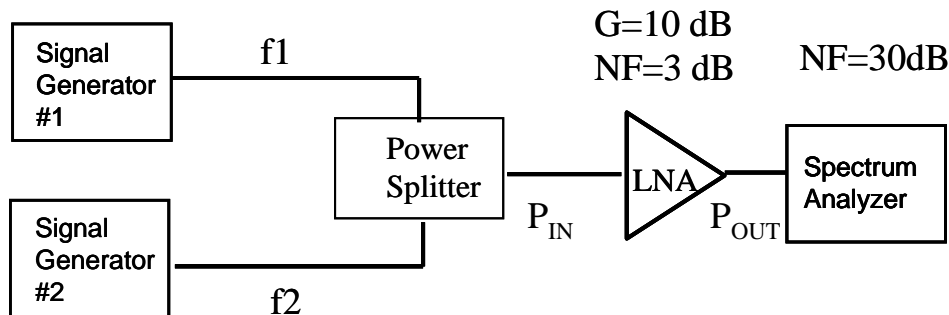

- If your spectrum analyzer has a $NF = 30$ dB, what is the total noise figure at the input of the system? (at P_{IN})
- Assume your spectrum analyzer has a 70 dB dynamic range. Find the minimum P_{IN} that could be used for the carrier-to-IMD measurement on the DOA-1. How much intermodulation power P_{IMD} would you measure?
- What is the maximum resolution bandwidth that could be used and still measure an P_{IMD} -to-noise ratio of 0 dB under this condition.
- Is this sufficient to make the measurement? List all of the spectrum analyzer parameter settings (values) needed to accurately perform this measurement.

Here is an exercise in the design of an amplifier for a gain and noise spec using a bilateral device (the same one you will use for your Lab 3 project). The devices are potentially unstable at the design frequencies. This exercise will take you part way in your LNA design project. Note that your homework design can be used as part of your Lab 3 report. For that reason, a detailed solution to problems 2 and 3 of homework 5 will not be given. I want to see your designs, not have you just follow my design.

2. ECE145A students only: (refer to the ADS Tutorial on Stability and Gain Circles and the ADS Noise Figure Analysis Tutorial on the course web page. Example ADS files are also available there.) Use the NE85639 S parameter model in the ADS components library - biased at 2.5V and 3mA - for this exercise.

- Use ADS to determine stability using the stability factor k and $\Delta = \det(S)$ from 50MHz to 5 GHz. Plot the source and load stability circles at 400 MHz on separate Smith chart displays. Identify clearly on the plots which region is stable and which is unstable.

- b. Show how to make the transistor unconditionally stable at 400 MHz on the load side by adding a stabilizing resistor. Explain how you predict the resistor value from a. and show that it produces an unconditionally stable device.
- c. Using the load side stabilization from part b, plot available gain circles for this device on the Γ_S plane. Also, plot noise figure circles on the same display. Determine suitable Γ_S and Γ_L to achieve at least 12 dB of gain at 400 MHz with noise figure less than 2 dB.
- d. Design lumped element matching networks which will provide the selected Γ_S and Γ_L . Simulate the complete amplifier gain and stability at 400 MHz to verify your design.
- e. Modify the matching network design adding low frequency resistive loading so that the amplifier will also be unconditionally stable from 50 to 500 MHz. Verify that the gain and noise figure at 400 MHz still meet specifications and that the amplifier will also be stable up to 5 GHz.

3. ECE218A students only: (refer to the ADS Tutorial on Stability and Gain Circles and the ADS Noise Figure Analysis Tutorial on the course web page. Example ADS files are also available there.) Use the NE85639 S parameter model in the ADS components library - biased at 2.5V and 3mA - for this exercise.

- a. Use ADS to determine stability using the stability factor k and $\Delta = \det(S)$ from 50MHz to 5 GHz. Plot the source and load stability circles at 800 MHz on separate Smith chart displays. Identify clearly on the plots which region is stable and which is unstable.
- b. Show how to make the transistor unconditionally stable at 800 MHz on the load side by adding a stabilizing resistor. Explain how you predict the resistor value from a. and show that it produces an unconditionally stable device.
- c. Using the load side stabilization from part b, plot available gain circles for this device on the Γ_S plane. Also, plot noise figure circles on the same display. Determine suitable Γ_S and Γ_L to achieve at least 10 dB of gain at 800 MHz with noise figure less than 2 dB.
- d. Design lumped element matching networks which will provide the selected Γ_S and Γ_L . Simulate the complete amplifier gain and stability at 800 MHz to verify your design.
- e. Modify the matching network design adding low frequency resistive loading so that the amplifier will also be unconditionally stable from 50 to 500 MHz. Verify that the gain and noise figure at 800 MHz still meet specifications and that the amplifier will also be stable up to 5 GHz.