

BJT Amplifier Design Project
Lab Project #3
UCSB/ECE145A
Winter 2008

Due Dates:

- 1. The PCB layout is due by 9 am on Mar 3, Monday at 9 AM.**
- 2. Report is due on March 14, Friday at 5 PM. Check sheet (verified by TA or Prof) must be turned in at the same time as the lab report.**

Goals:

- Design, construction and evaluation of a 400 MHz low noise amplifier using the NE85639 BJT
- Introduction to stabilization of amplifiers, biasing, and design for gain, noise, and frequency

Reading: Notes set #5-9, Biasing notes, ADS stability and gain tutorial, ADS noise figure tutorial, PCB Layout information for Lab 3.

Safety Precautions:

Ensure that the input and output of your circuit is dc blocked (No DC level) before connecting to the spectrum analyzer, network analyzer, or any other test equipment.

Background:

Bandpass RF amplifiers are often used in receiver front ends to improve sensitivity and noise performance. You will be designing this amplifier for the minimum noise figure while guaranteeing unconditional stability at all frequencies when terminated at the input and output with 50 ohms. You should obtain good return loss (< -10 dB) at the output at the minimum noise figure frequency.

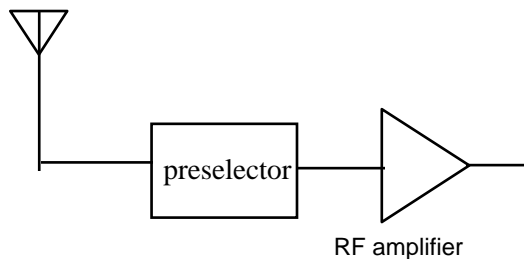

Specifications

S22	Less than -10 dB @ min. NF frequency
Gain	Greater than 12 dB at min. NF
Frequency	Min. NF @ 400 MHz +/- 30 MHz
Noise Figure	Less than 2 dB
Power Supply	+ 3.5 volts

Design Procedure: Complete HW #5 before building your amplifier!!!

The device you will use is the NEC 85639. There are models for this device in the ADS component library.

Model type	Library	Sub-Library	Model name
S-parameter (0.05-3.0 GHz)	S Parameter Lib.	NEC	sp_nec_NE85639_3_19940401
Nonlinear	RF Transistor Lib.	Packaged BJTs	NE85639_19960601

Design an amplifier at 400 MHz based on the NE85639 BJT. Bias the device with $V_{CE} = 2.5V$ and $I_C = 3 mA$. Note that this device is bilateral and potentially unstable at this frequency.

- (a) Use Agilent ADS to plot source and load stability circles for just the device. Use the above device from the S-Parameter Library/NEC section of the ADS Components library to simulate the device operation using the S parameter mode of simulation. You will see that the device is unstable over a wide range of frequencies ($k < 1$). Modify the design by adding some stabilization element(s) so that the device is unconditionally stable at the design frequency and higher. (Refer to the Stability and Gain Circles notes and ADS tutorial files) It will now be possible to match the device input for noise. (Note: instability at lower frequencies will be addressed later in the design process by appropriate choice of DC blocking capacitors and introduction of frequency-dependent resistive loading)
- (b) Note that the device is bilateral. Determine Γ_S and Γ_L using available gain circles and noise circles. Design the matching network (**YOU MUST HAVE A DC BLOCKING CAPACITOR AT BOTH INPUT AND OUTPUT!!!!**). Your matching networks can be either lumped or distributed. Simulate again and verify that the gain, center frequency, noise figure and output return loss ($20 \log |S_{22}|$) of the amplifier with its matching networks meet or exceed specifications. You need to consider the non-ideality of your components with appropriate models in order to be successful in having your design work the first time. Use the microstrip transmission line models described below to improve accuracy. If you decide to use lumped inductors in your design, there are equivalent circuit models on the course web page for the 0603 Coilcraft chip inductors. There is a limited supply of these in the lab in a sample kit –use sparingly.
- (c) Make sure that the out-of-band behavior of the matching networks does not put the device into an unstable region on the source or load planes. Verify that the device will be stable at 400 MHz and over a wide frequency range (50 MHz to 3 GHz). You should consider adding some additional stabilization element that provides resistive loading at low frequencies but not at high if stability at low frequencies is a problem. (Hint: a resistor in series with a shunt leg or in parallel with a series capacitor of the matching network can be effective at damping low frequency instabilities).

- (d) Next you must decide how to introduce bias to the device. You may be able to introduce it through the matching networks or with an RF choke. Use an active biasing approach to guarantee a stable bias point over supply variation, device variation and temperature. Refer to the bias circuit notes for examples. You will find some components in your parts kit for the active bias circuit.
- (e) Now, resimulate the entire amplifier using the nonlinear model for the NE85639, found in the ADS RF Transistor Library > Packaged BJTs. Predict the 1 dB compression point through harmonic balance simulation. Verify that the amplifier is also stable from 1-50 MHz and 3 – 5 GHz.

Constructing the amplifier:

This year, we will be fabricating custom PC boards for lab 3 through the internet PCB vendor, ExpressPCB. Please read the instructions on PCB Layout for Lab 3. The boards are subject to the following restriction:

- The PCB dimensions must be 2 x 2.5 inches.
- Board material is FR-4. You should assume $\epsilon_r = 4.5$.

You can access the layout software on the PCs in 5162 or ECI. Or you can download the software onto your own PC. In either case, visit <http://www.expresspcb.com> for an orientation on their layout software and board specifications. If you use your own PC, then you must also download the component footprint for the NE85639 that is found on the course website. Copy this file into the following directory:

Programs\ExpressPCB\PCBComponents_Custom

When your layout is ready to submit, carefully check it against your schematic. Then email the .pcb file to: long@ece.ucsb.edu. I will submit all of the layouts for the class in one batch.

THE BOARD LAYOUTS ARE DUE BY 9 am ON MONDAY, Mar 5.

Testing the amplifier:

Measure your amplifier's performance to verify that your design meets specs. Compare measured with simulated performance. Demonstrate operation to the TA or Prof.

- a. Set bias. Terminate input and output with a 50 ohm load or an attenuator, apply V_{CC} to the amplifier, and set V_{CE} and I_C using the variable resistors. Record these values in your notebook.
- b. You must verify that the amplifier is stable with 50 ohm source and load. Connect the amplifier output to the spectrum analyzer and the input to a signal generator. Adjust the analyzer for a span of approximately 1 MHz to 1.8 GHz. You should see no indication of output on the SA at any frequency when the generator is off, and only an output at 400 MHz when the generator is on.

Next determine:

1. Gain and Input/Output Return Loss. (Make sure that the power level setting on the NA is small – well below the P_{1dB} input power¹. P_{1dB} may be somewhere around -25 dBm.) Plot S_{11} , S_{12} , S_{21} , and S_{22} over the frequency range 50 MHz – 500 MHz.
2. Measure noise figure of the amplifier. Determine the frequency for minimum NF.
3. Measure the input P_{1dB} compression power at the frequency that gives you minimum noise figure. Show a plot of P_{out} vs. P_{in} in your report.
4. Measure DC power dissipation of your amplifier.

Active Bias Circuit (see Bias Circuit Design notes for details. Also, matching network shown is just an illustration – not intended to necessarily be appropriate for the Lab 3 design). R2 and R3 should be leaded resistors. R1 and R4 are trimmer pots. C1 is a polarized Tantalum capacitor for low frequency AC grounding. Observe the polarity when installing. C2 – C4 are RF bypass capacitors.

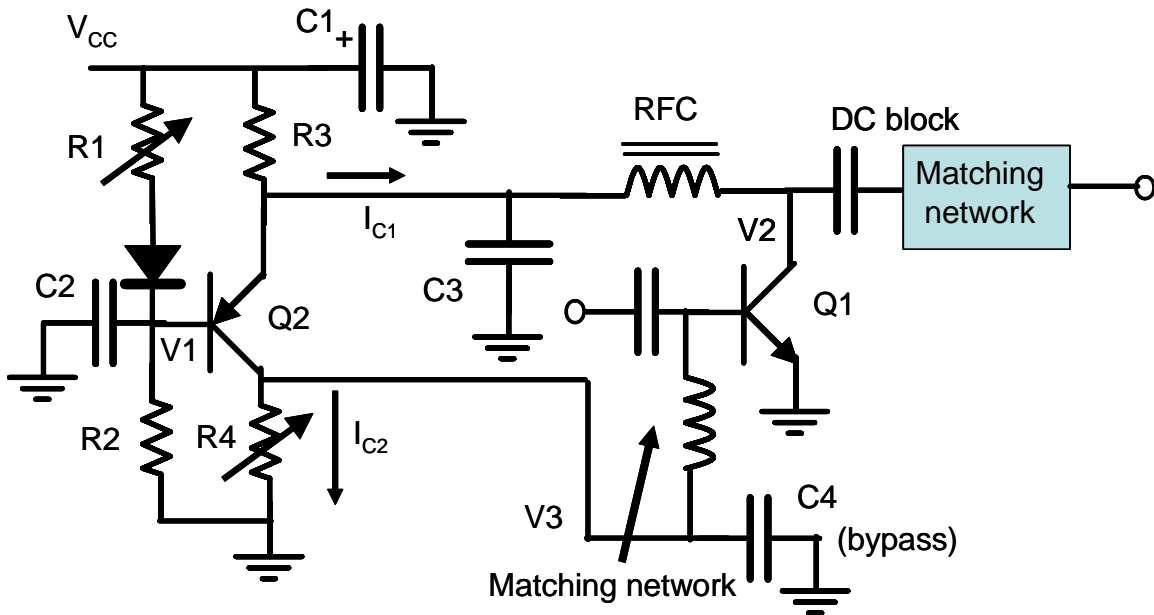

2N3904

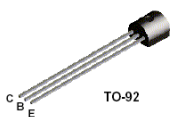

Same for 2N3906

Microstrip line modeling in ADS.

You have used the ideal transmission line TLIN and open and shorted stubs in the homework assignments. You should be aware that there is a more accurate set of microstrip line models and elements in another menu (TLines-Microstrip) and palette.

¹ The 1 dB compression power is usually specified as the power level at the input of the amplifier which compresses the transducer power gain by 1 dB.

These elements take into account some of the nonidealities of the line: corners, tees, and losses. Msub is used to describe the line and dielectric. MLIN is a series line section. MLOC is an open circuit stub; MLSC is a short circuit stub. Mcorn represents a right angle corner without a miter bend. MBend represents a mitered corner. MTEE is a T junction. Note that the length of the stub is measured from the center of the transmission line at the T junction.

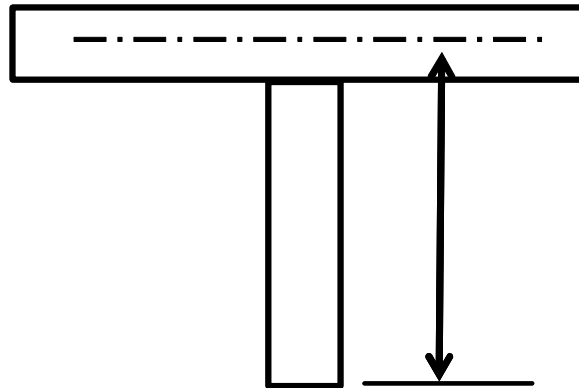

You should use models such as these when simulating the final version of your circuit.

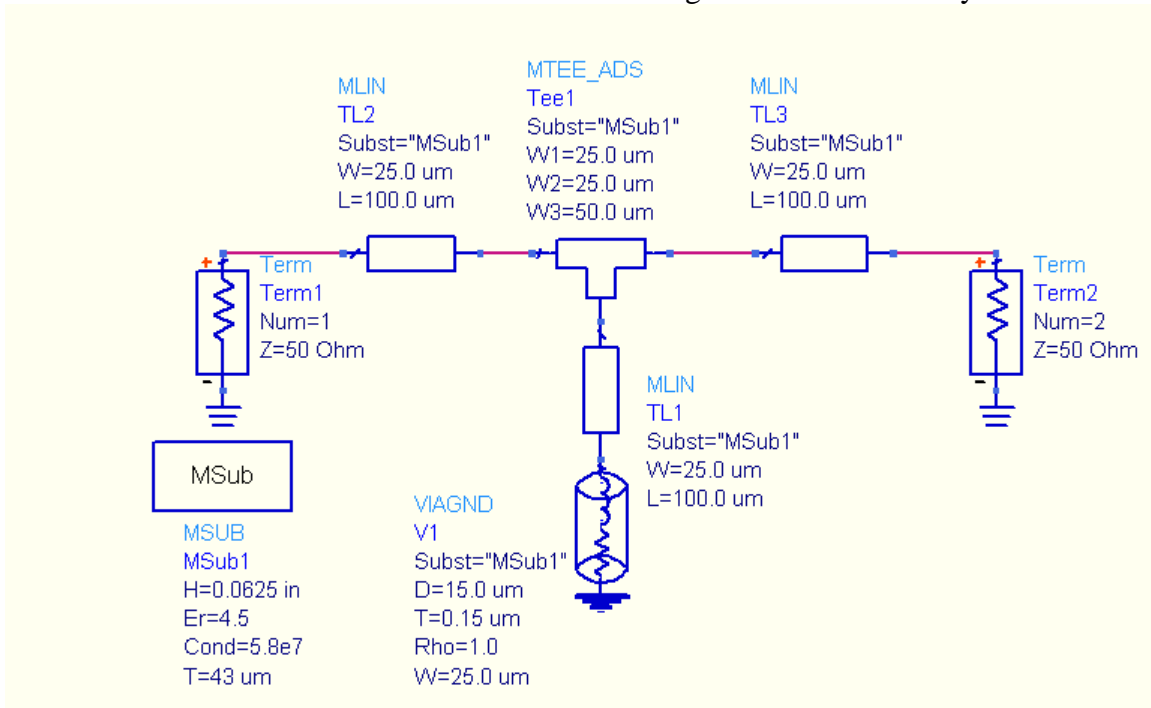

Checkout Sheet for Lab 3

You must demonstrate to the TA or Prof. the following:

1. Device is biased to 2.5V; 3 mA
 2. Demonstrate stability with spectrum analyzer from 10 MHz to 1.8 GHz with both RF input off and on.
 3. Zoom in on the output and verify that there are no sidebands.
 4. Demonstrate gain and noise figure specs are met at design frequency
 5. Demonstrate that S22 also meets spec at design frequency.
-

Parts List – ECE145A, Lab 3 Winter 2008:

- | | |
|---|--|
| 1 | SMA female board-mounted connector |
| 1 | SMA male board-mounted connector |
| 1 | NE 85639 surface mount transistor |
| 2 | 2N3906 PNP BJT |
| 1 | 2k Bourns 3386P potentiometer |
| 1 | 10k Bourns 3386P potentiometer |
| 2 | 0.47 uH RF choke |
| 1 | 4.7 uF Tantalum capacitor |
| 2 | 24" lengths of insulated wire (#24) for power supply connections |