

1. Identify the feedback configuration and feedback network in each of the circuits below. Estimate the closed loop gain assuming that the open loop gain is very large. Convert the gain into the form that is implied by each input and output variable.

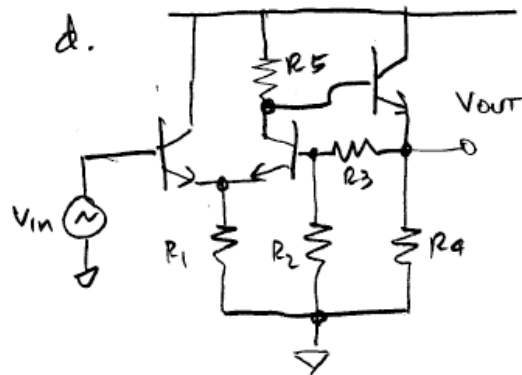

2. The circuit shown below is a feedback amplifier.

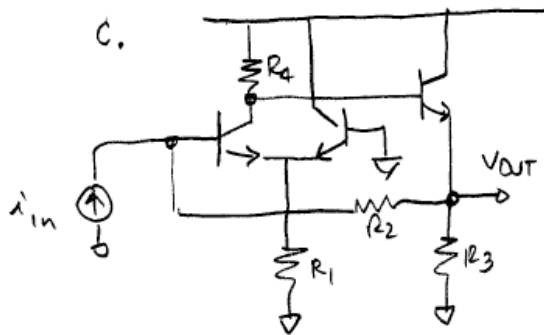
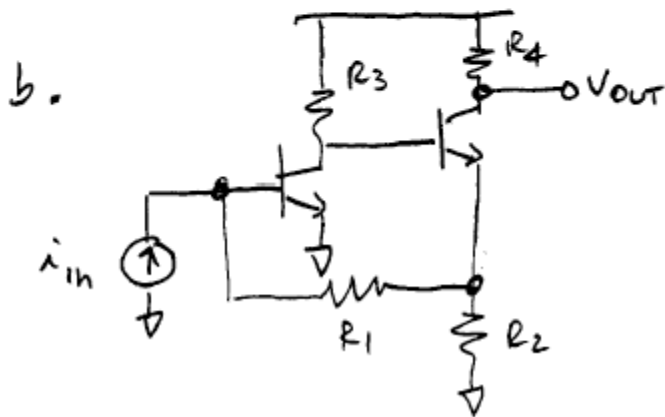
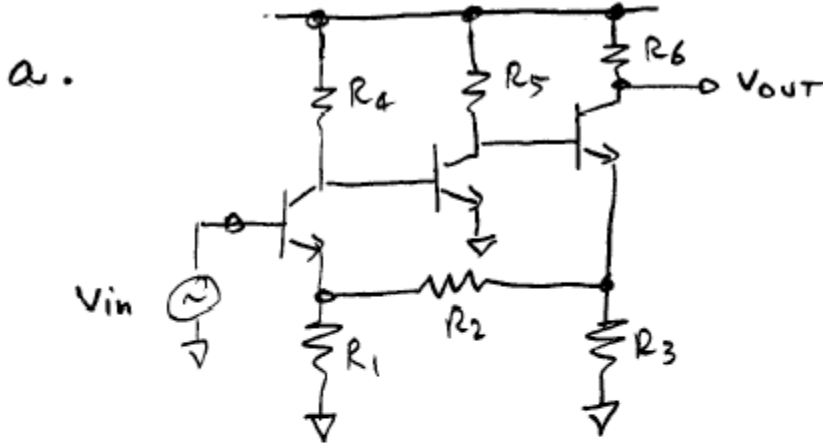
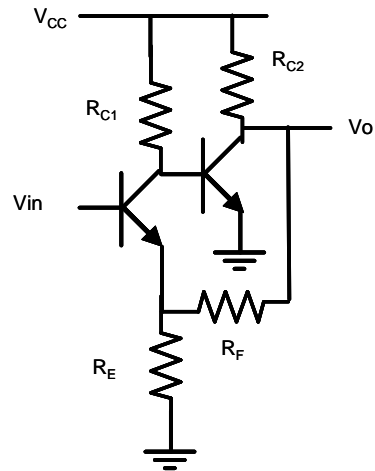

- Identify the feedback configuration and feedback network. Estimate the closed loop gain assuming that the open loop gain is very large.
- Draw the small signal model of the basic amplifier loaded by the feedback network. Derive an equation for  $a_o$ , the low frequency open loop gain of the amplifier.

c. Next, assume the basic open loop amplifier has two negative real poles with magnitudes 4 and 10 MHz, and the low frequency voltage gain of the basic amplifier is 4000.  $R_F = 1k$  and  $R_E = 10\Omega$ . Draw Bode plots for the open loop gain and phase. Find the crossover frequency. Estimate the phase margin.

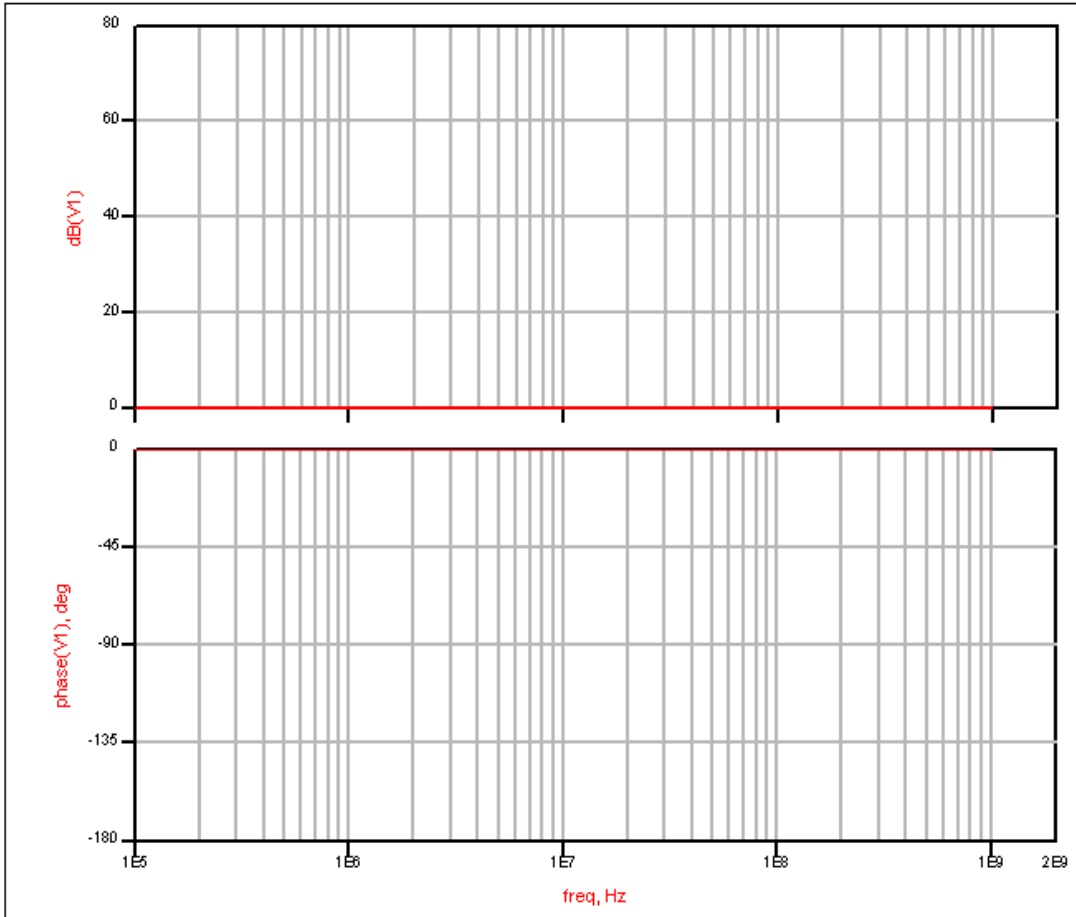

d. Now assume that a feedback capacitor,  $C_F = 4 \text{ pF}$ , is added in parallel with  $R_F$ . Calculate the frequency of the pole and the zero contributed by this capacitor. Plot the new Bode plots for the compensated amplifier. Again estimate the phase margin. Why is it valid in this case to neglect the extra pole that results from this compensation method?

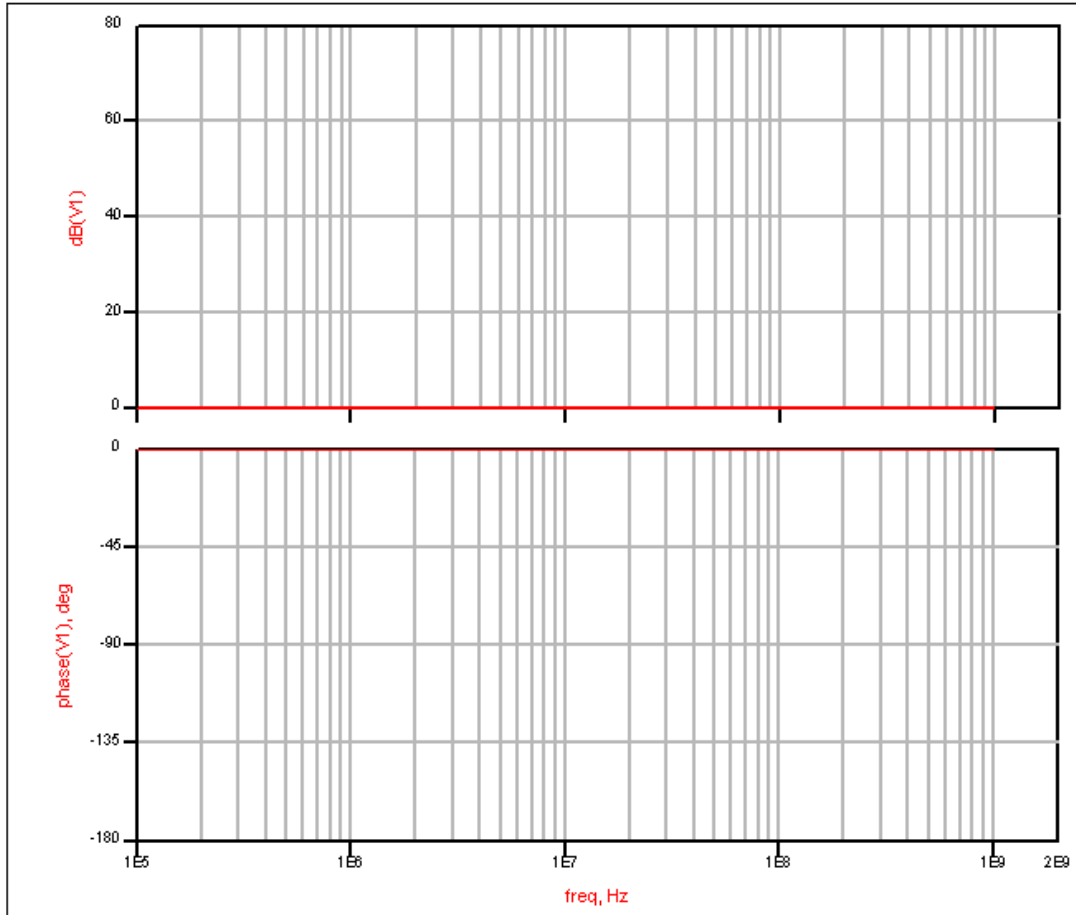

e. Find  $\omega_n$  and  $\zeta$ . Using the equations for second order low pass systems given in Lee's book (Sect 14.11.2) and also in the lecture notes, estimate the closed loop gain peaking, frequency of maximum gain, 3 dB bandwidth, and overshoot in the step response for the uncompensated and compensated cases. (Don't forget to convert from Hz to radians/sec for this calculation).

Why is it valid to use these equations when there is a zero present? (refer to G&M Sect. 9.5 – p. 113 – 119 in the supplemental reader).

Sketch the closed loop magnitude response of the uncompensated and compensated case.

Uncompensated:

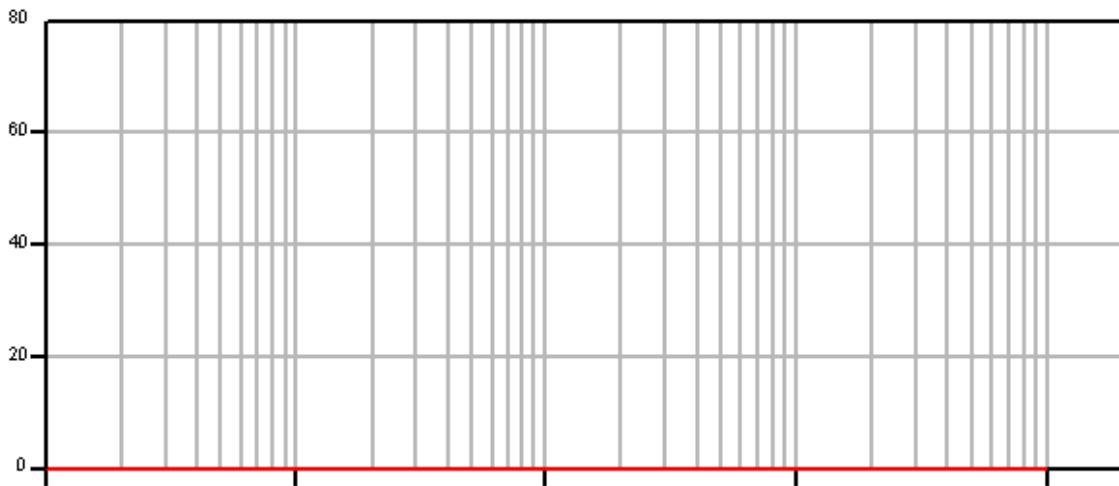

Compensated:

