

Structure of silicon crystal

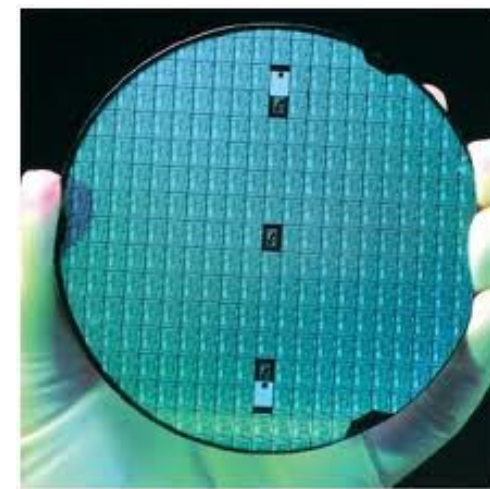
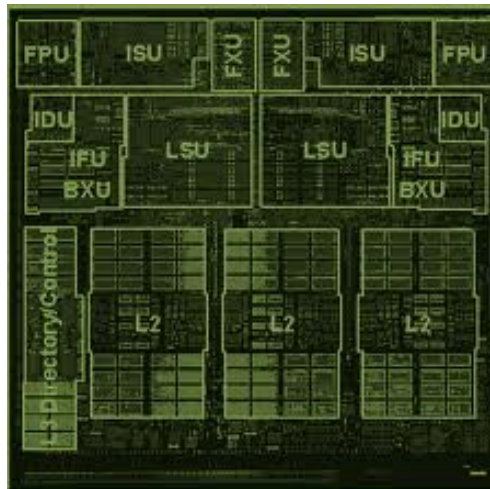
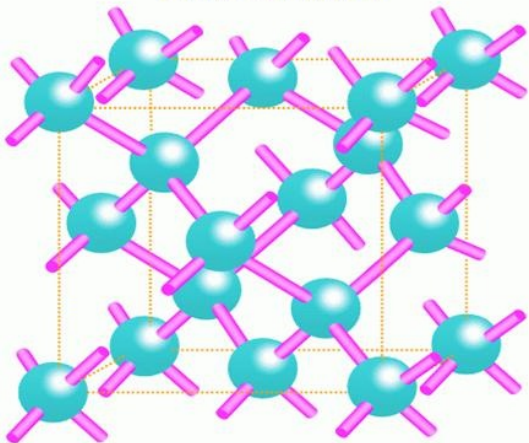

ECE 122A

VLSI Principles

Lecture 12

Prof. Kaustav Banerjee
Electrical and Computer Engineering
University of California, Santa Barbara
E-mail: kaustav@ece.ucsb.edu

Designing Combinational Logic Circuits

Static Vs Dynamic Circuits

Static Circuits

At every point in time (except during the switching transients) each **gate output is connected to either V_{DD} or V_{SS}** via a low-resistive path.

The outputs of the gates **assume at all times the value of the Boolean function**, implemented by the circuit (ignoring, once again, the transient effects during switching periods).

This is in contrast to the **dynamic** circuit class, which relies on temporary storage of signal values on the capacitance of high impedance circuit nodes.

Resulting gate is simpler and faster, but increased sensitivity to noise....

Static and Dynamic CMOS Circuit Families

- Static:
 - Complementary CMOS
 - (robustness, low power, large fan-in expensive in terms of area and performance)
 - Ratioed Logic: pseudo-NMOS, differential cascode voltage switch logic (DCVSL)
 - (simple and fast at the expense of reduced NM and static power)
 - Pass-Transistor Logic (Transmission Gate)
 - attractive for specific circuits: MUX, XOR-dominated logic such as Adders)
- Dynamic:
 - good for fast and complex gates, design process is harder due to parasitic effects, leakage puts an upper limit on the operating frequency of the circuit
 - Domino Logic
 - np-CMOS

Which style is best?

.....depends on ease of design, performance, power, area and robustness.

Complementary CMOS Logic

- ❑ Full rail-to-rail swing; **high noise margins**
- ❑ Logic levels not dependent upon the relative device sizes; **ratioless**
- ❑ Always a path to Vdd or Gnd in steady state; **low output impedance**
- ❑ Extremely **high input resistance**; nearly zero steady-state input current
- ❑ No direct path steady state between power and ground; **no static power dissipation**
- ❑ Propagation delay function of load capacitance and resistance of transistors

Static Complementary CMOS

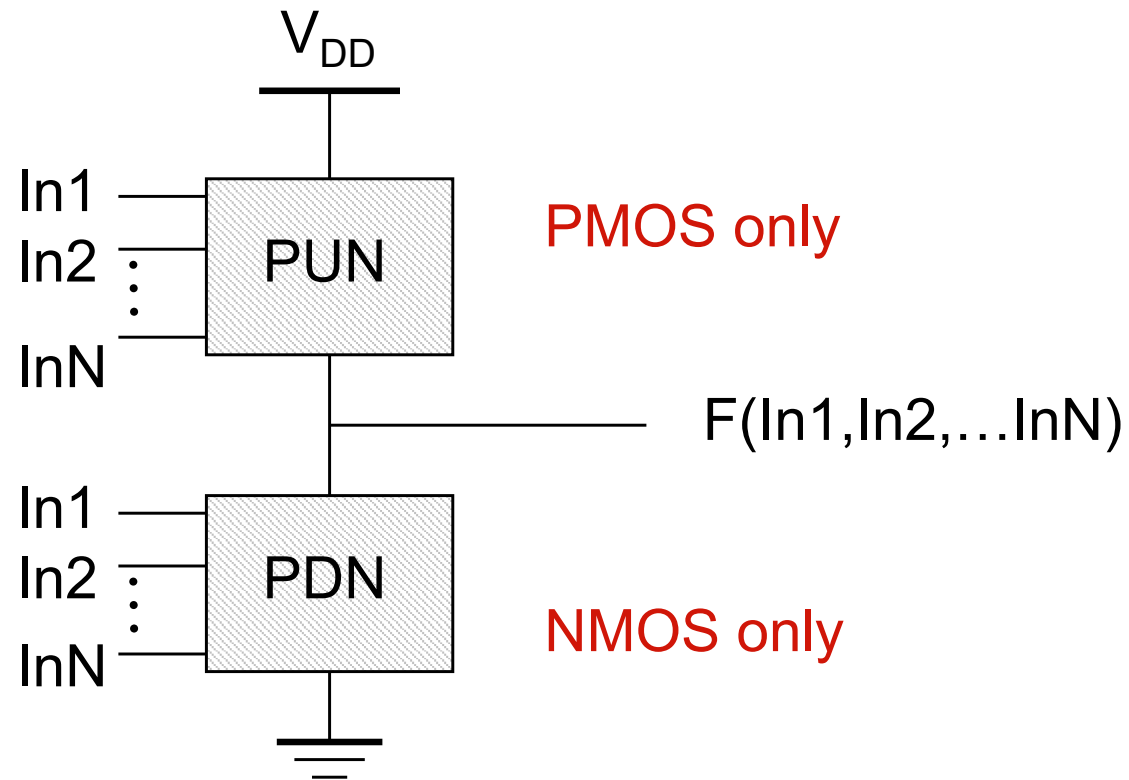

PUN and PDN are **dual** logic networks

Dual Networks

- Dual networks: parallel connection in PUN = series connection in PDN, vice-versa
- If CMOS gate implements logic function F :
 - PUN implements function \overline{F}
 - PDN implements function $G = F$

Example: NAND gate

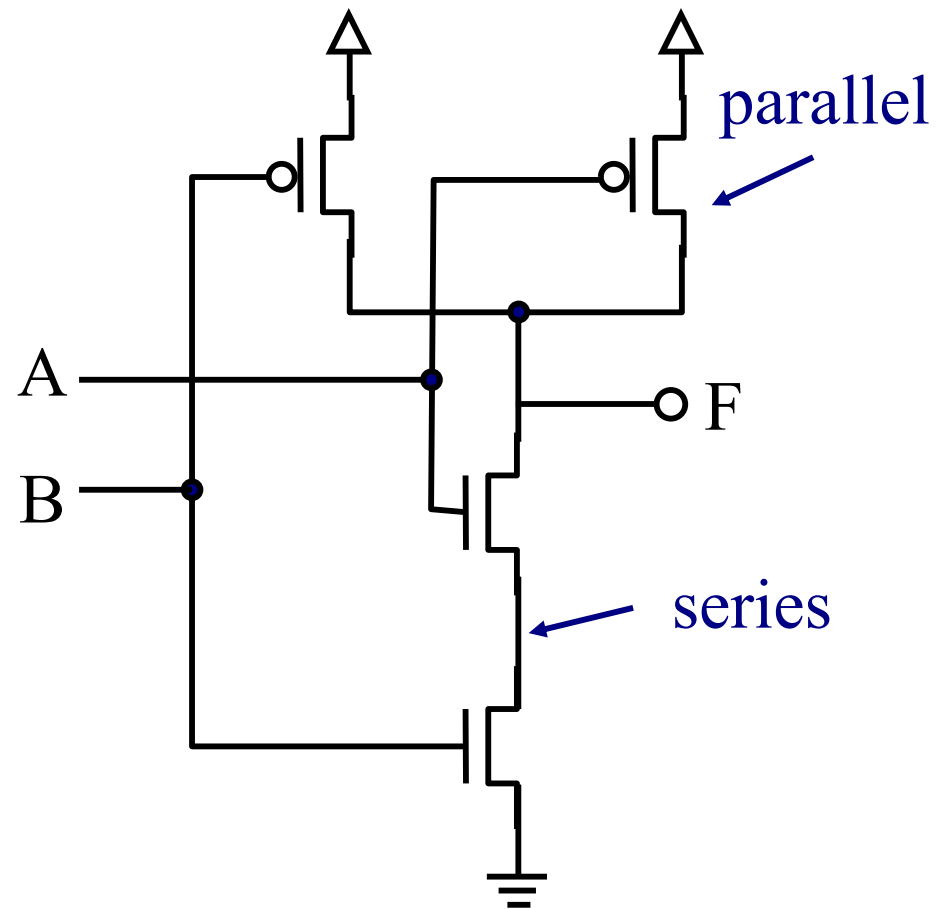

Key Properties of Complementary CMOS Gates: Snapshot

High noise margins

V_{OH} and V_{OL} are at V_{DD} and GND , respectively.

No static power consumption

There never exists a direct path between V_{DD} and V_{SS} (GND) in steady-state mode.

Comparable rise and fall times:

(under appropriate sizing conditions)

Analysis of CMOS gates

□ Represent “on” transistors as resistors

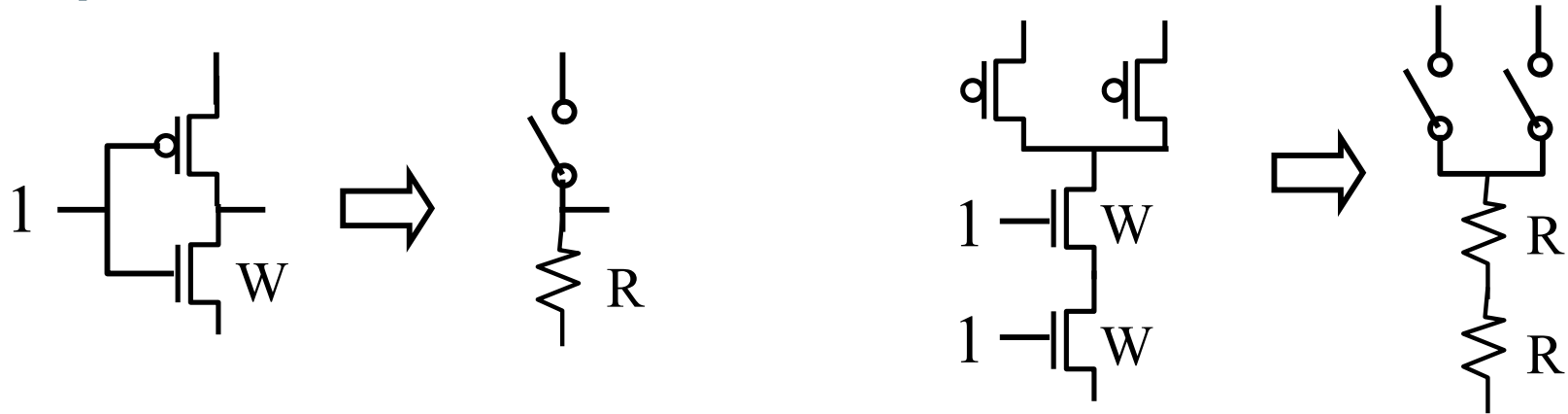

- Transistors in series \rightarrow resistances in series
 - Effective resistance = $2R$
 - Effective width = $\frac{1}{2} W$

Note: 1) As transistor width increases, its ON resistance (R) decreases

2) If transistor channel length increases, R increases

Analysis of CMOS Gates, contd...

- Represent “on” transistors as resistors

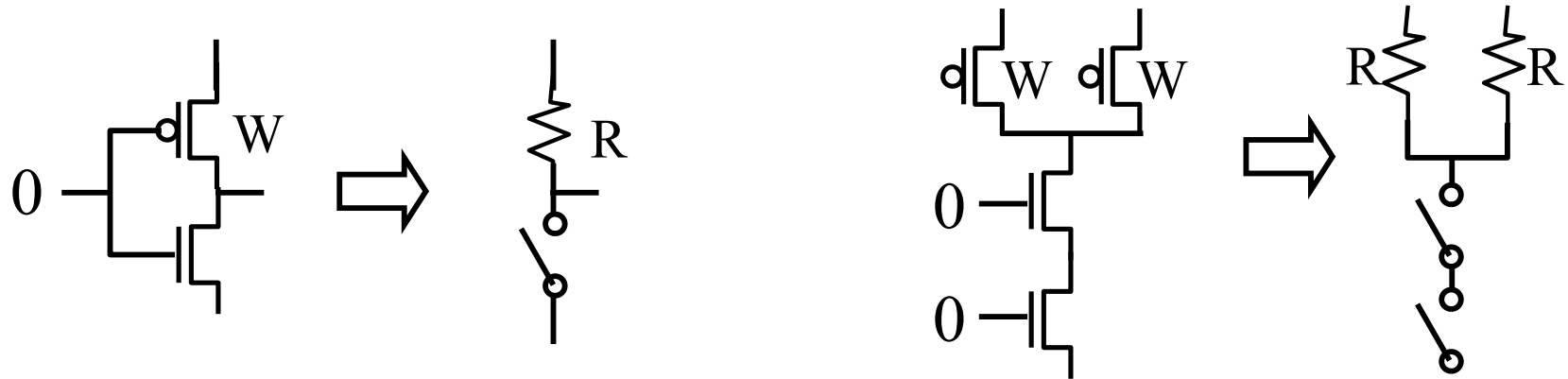

- Transistors in parallel \rightarrow resistances in parallel
 - Effective resistance = $\frac{1}{2} R$
 - Effective width = $2W$

Equivalent Inverter

- CMOS gates: many paths to V_{cc} and Gnd
 - Multiple values for V_M , V_{IL} , V_{OL} , etc
 - Different delays for each input combination
- Equivalent inverter
 - Represent each gate as an inverter with appropriate device width
 - Include only transistors which are ON or switching
 - Calculate V_M , delays, etc using inverter equations

CMOS gates: equivalent inverter

- Represent complex gate as inverter for delay estimation
- Use worst-case delays
- Example: NAND gate
 - Worst-case (slowest) pull-up: only 1 PMOS “on”
 - Pull-down: both NMOS “on”

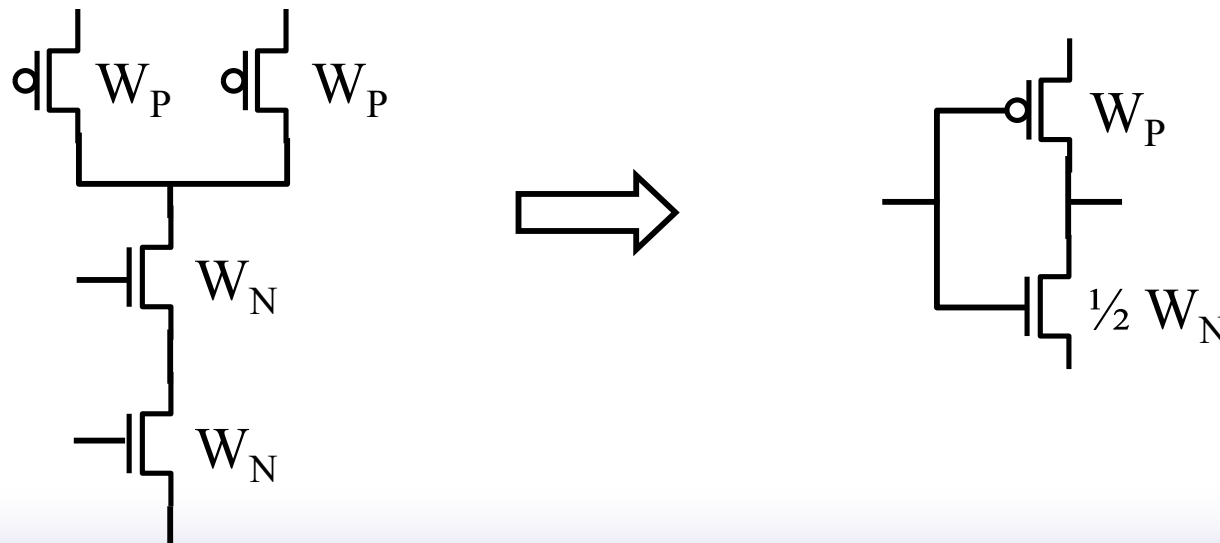

Equivalent Inverter: V_M

□ Example: 2-input NAND gate threshold V_M

Three possibilities:

- A & B switch together
- A switches alone
- B switches alone

Hint: the VTC curve is data dependent

□ What is equivalent inverter for each case?

Example: NOR gate

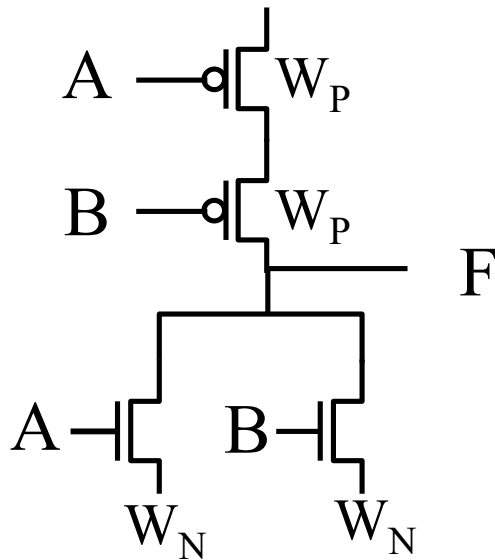

- Find threshold voltage V_M when both inputs switch simultaneously
- Two methods:
 - Transistor equations
 - Equivalent inverter

Switch Delay Model

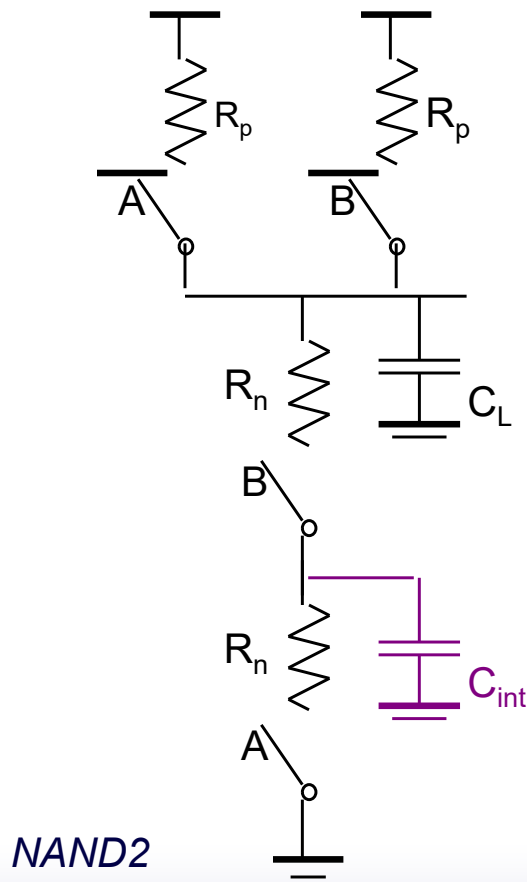
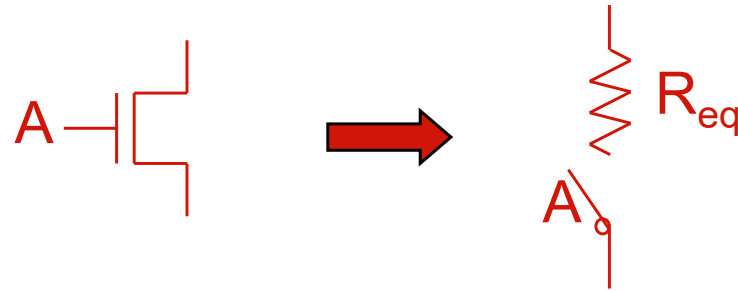

NAND2

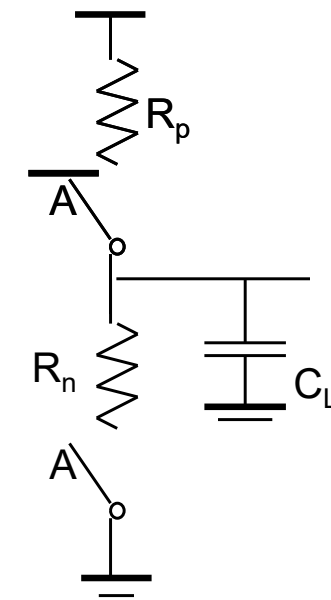

INV

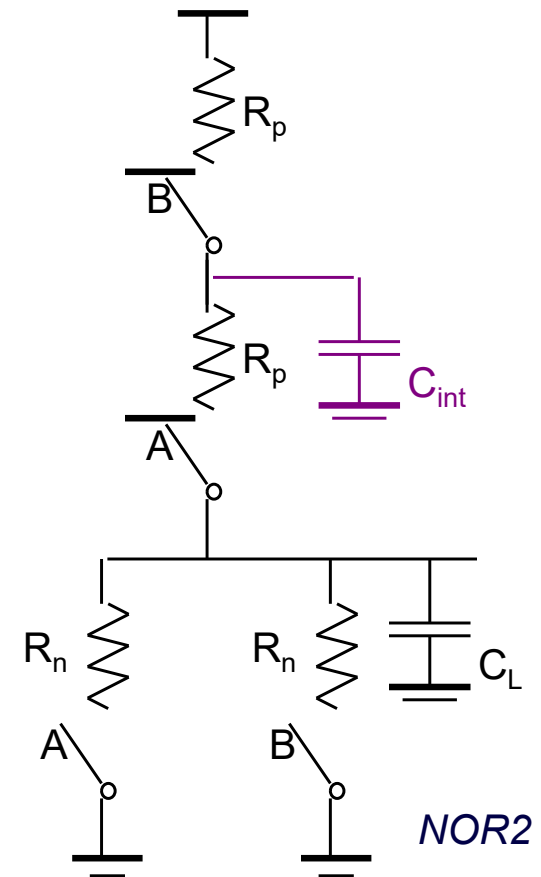

NOR2

Input Pattern Effects on Delay

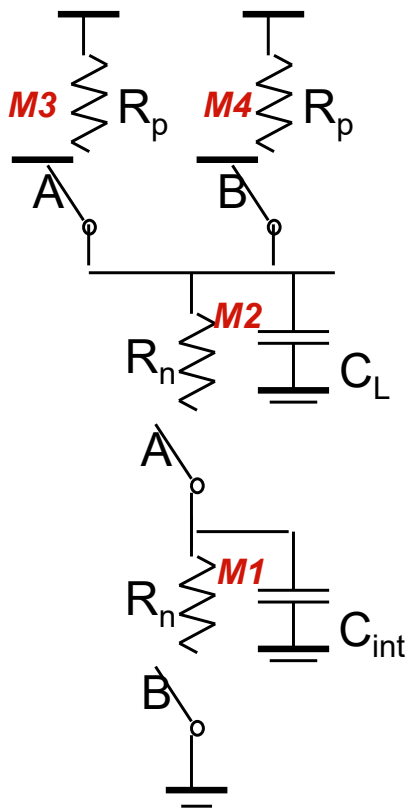

2-input NAND

- Delay is dependent on the **pattern** of inputs
- Low to high transition
 - both inputs go low
 - delay is $0.69 R_p/2 C_L$
 - one input goes low
 - delay is $0.69 R_p C_L$
- High to low transition
 - both inputs go high
 - delay is $0.69 2R_n C_L$

Delay Dependence on Input Patterns

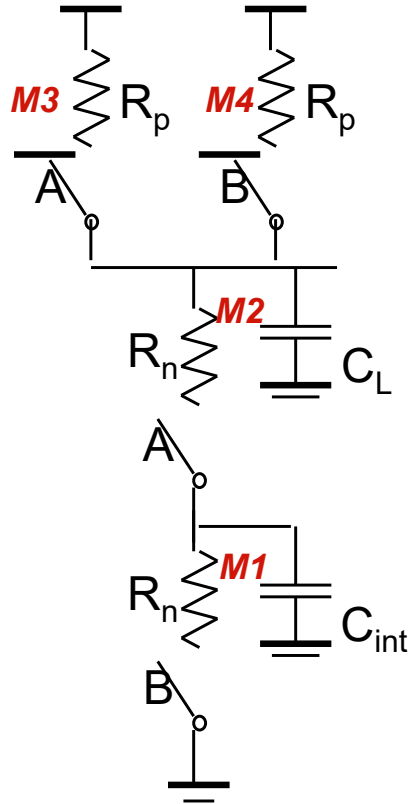

2-input NAND

- ❑ **High to Low Delay** depends on the initial state of the internal nodes
- ❑ Example: when both inputs transition from 0 to 1, it is important to know the state of the internal node (between M1 and M2)
- ❑ **Worst case:** when internal node is initially charged up to $V_{DD} - V_{tn}$. This can be ensured by pulsing the A input from 1-(0-1), while B only makes the 0-1 transition.

Bottom Line: Delay estimation can be a fairly complex affair and requires careful consideration of the internal node caps. and data patterns

Delay Dependence on Input Patterns

Simulated **Low to High** delay for a 2-input NAND

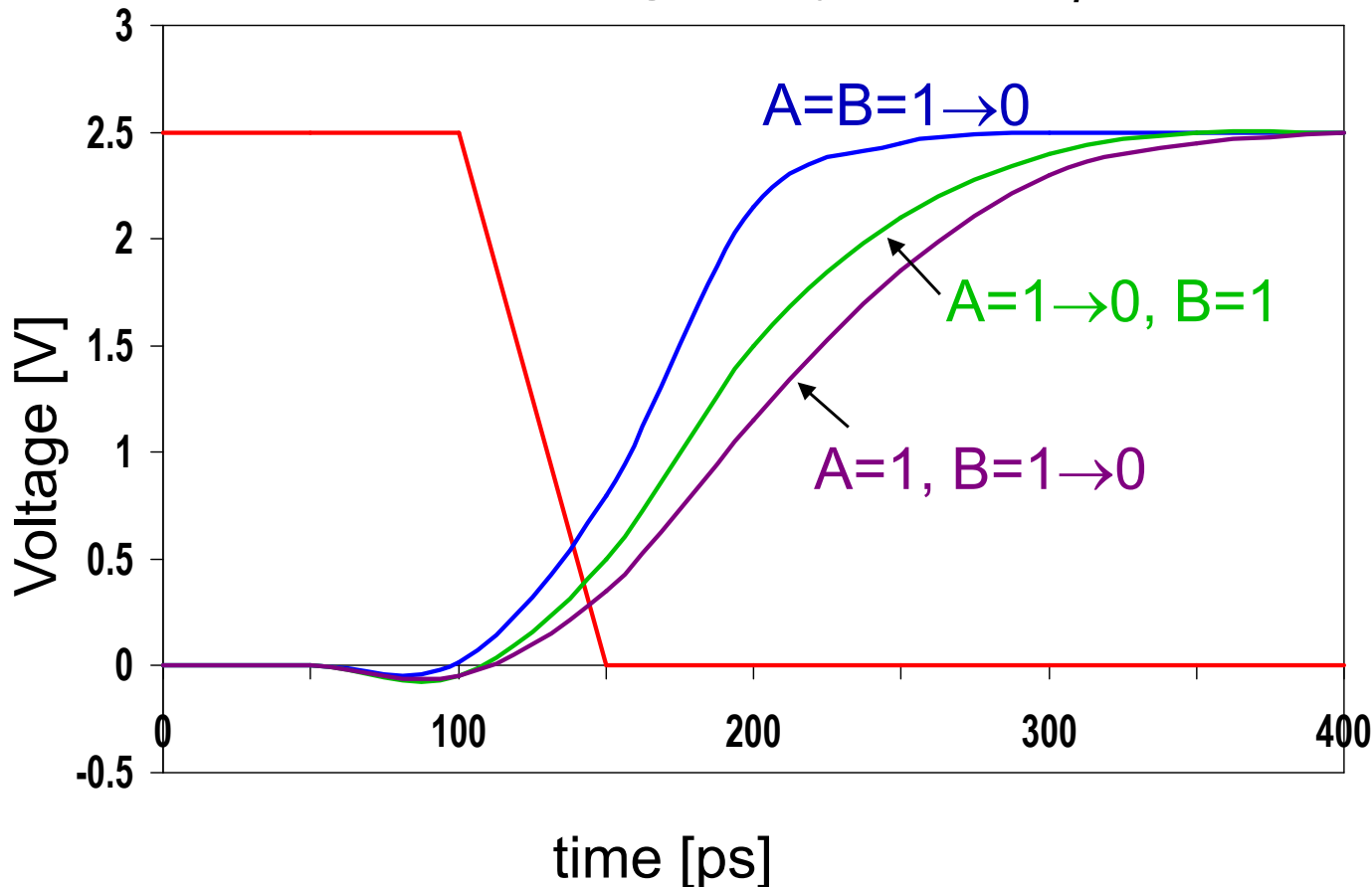

Note: worst case L-H delay depends on which input (A or B) is driven low (due to internal node cap of PDN stack: source of M2)

Input Data Pattern	Delay (psec)
$A=B=0 \rightarrow 1$	69
$A=1, B=0 \rightarrow 1$	62
$A=0 \rightarrow 1, B=1$	50
$A=B=1 \rightarrow 0$	35
$A=1, B=1 \rightarrow 0$	76
$A=1 \rightarrow 0, B=1$	57

NMOS = $0.5\mu\text{m}/0.25\mu\text{m}$
PMOS = $0.75\mu\text{m}/0.25\mu\text{m}$
 $C_L = 100\text{ fF}$

Revisit Transistor Sizing....

- Sizing for switching threshold
 - All inputs switch together
- Sizing for delay
 - Find **worst-case** input combination
- Find equivalent inverter, use inverter analysis to set device sizes

Recall Transistor Sizing....

What sizing will lead to a 2:1 equivalent inverter?

For effective $R_p = R_n$, we need $W_p = 2W_n$

Since two NMOS are in series, each should have $R_n/2$, hence each NMOS size, $W_n = 2$

Each PMOS should be such that $R_p = \text{effective } R_n$ (which corresponds to $W_n = 1$)

Hence, $W_p = 2$ (effective $W_n = 1$)

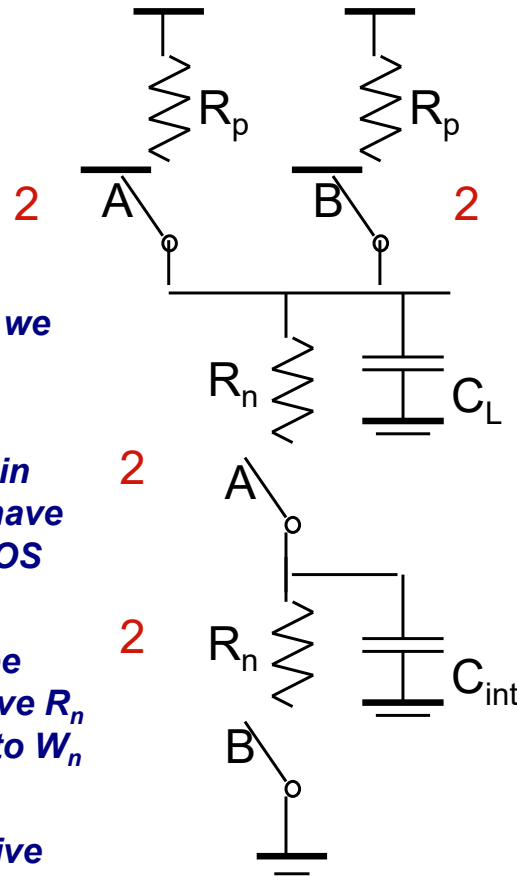

2-input NAND

For effective $R_p = R_n$, we need $W_p = 2W_n$

Also, since two PMOS are in series, each should have $R_p/2$

Hence, W_p of each should be $4W_n$

Avoid stacking PMOS transistors in series....

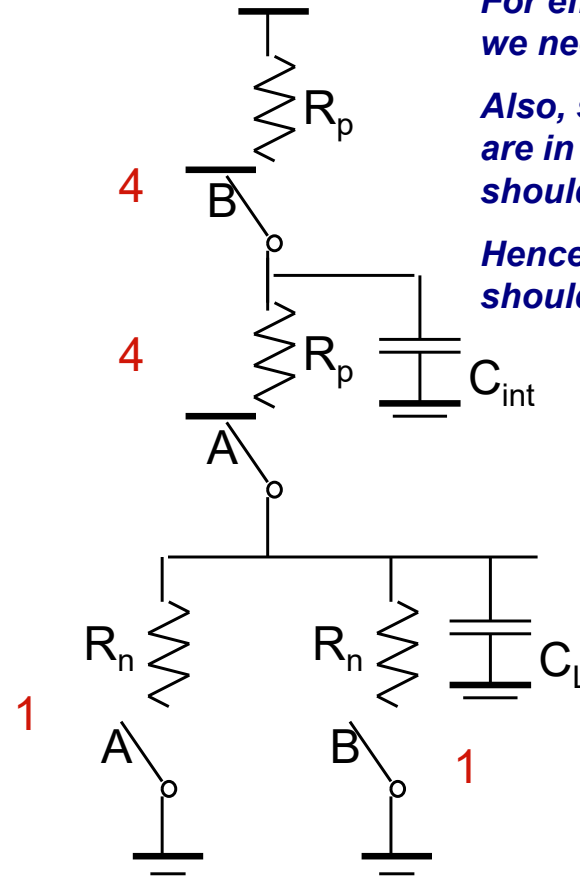

2-input NOR

Example: complex gate (1)

Design CMOS gate for this truth table:

A	B	C	F
0	0	0	1
0	0	1	1
0	1	0	1
0	1	1	1
1	0	0	1
1	0	1	0
1	1	0	0
1	1	1	0

$$F = \overline{A \cdot (B + C)}$$

Example: complex CMOS gate (1)

Design CMOS gate for this logic function:

$$F = \overline{A \cdot (B + C)}$$

1. Find NMOS pulldown network diagram:

$$G = \overline{F} = A \cdot (B + C)$$

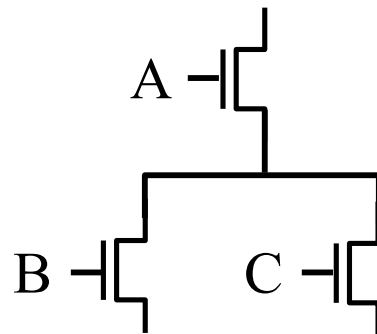

Example: complex CMOS gate (1)

Completed gate:

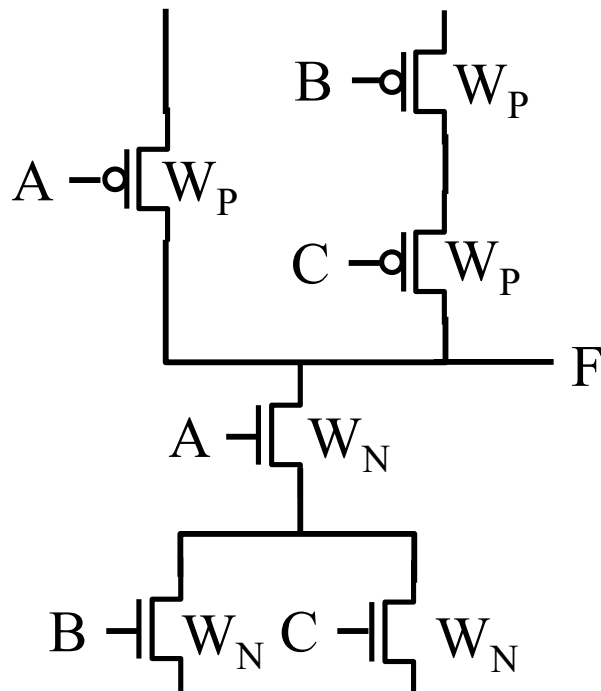

- What is worse-case pullup delay?

BC

- What is worse-case pulldown delay?

AB or AC

- Effective inverter for delay calculation:

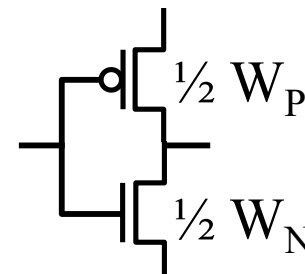

Example: complex CMOS gate (2)

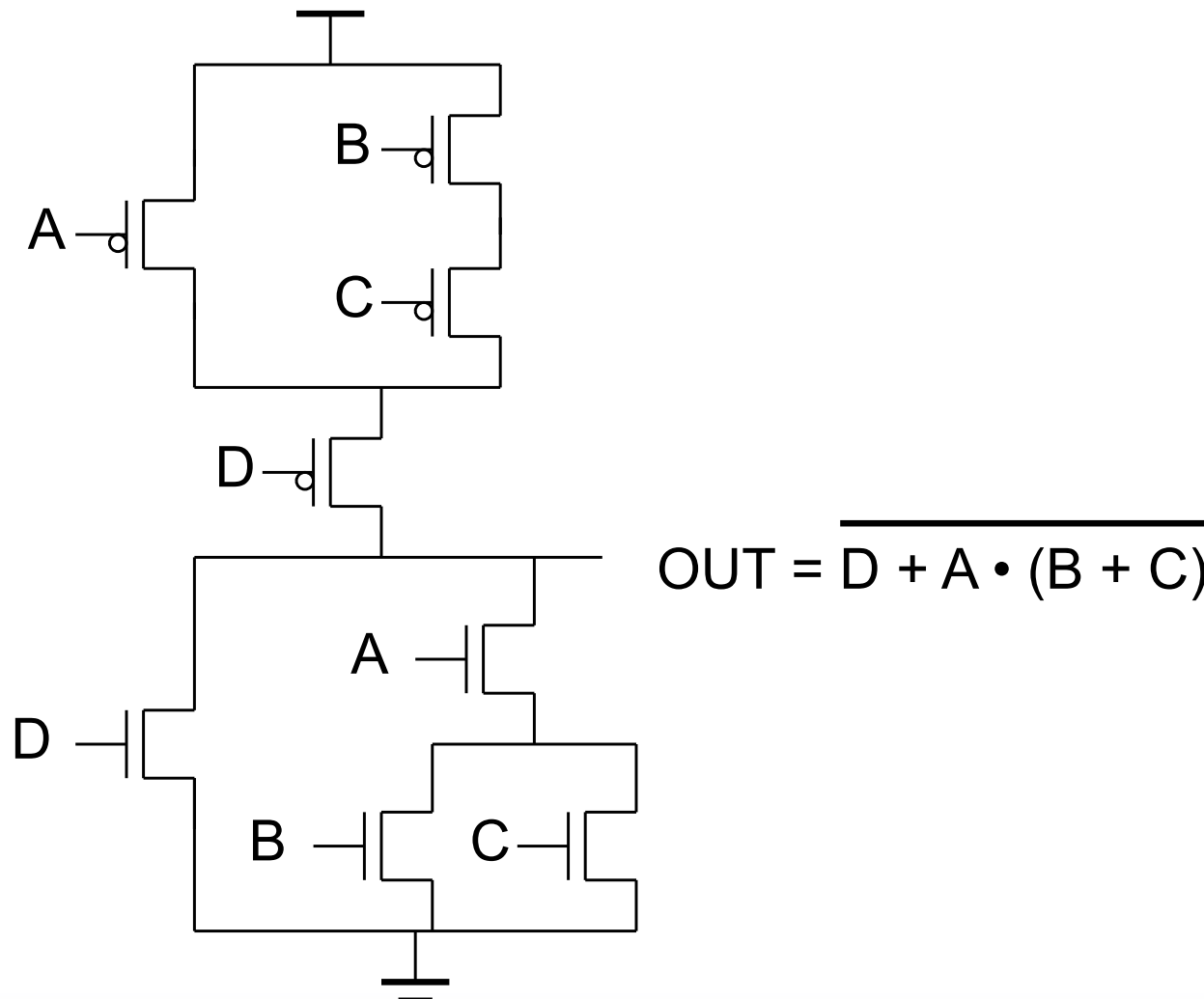

Example: complex CMOS gate (2)

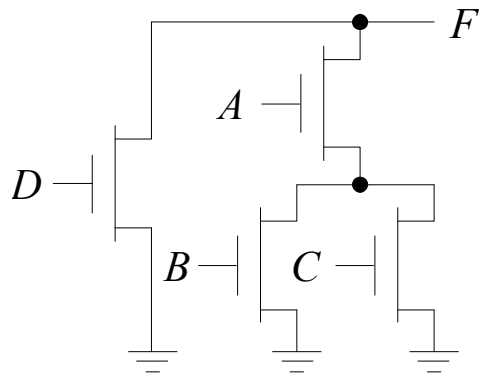

(a) pull-down network

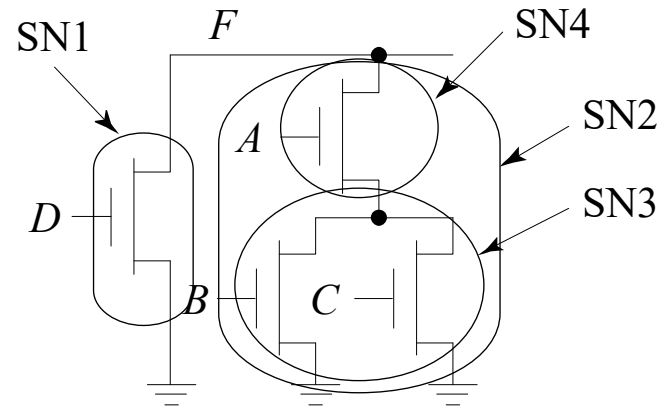

(b) Deriving the pull-up network hierarchically by identifying sub-nets

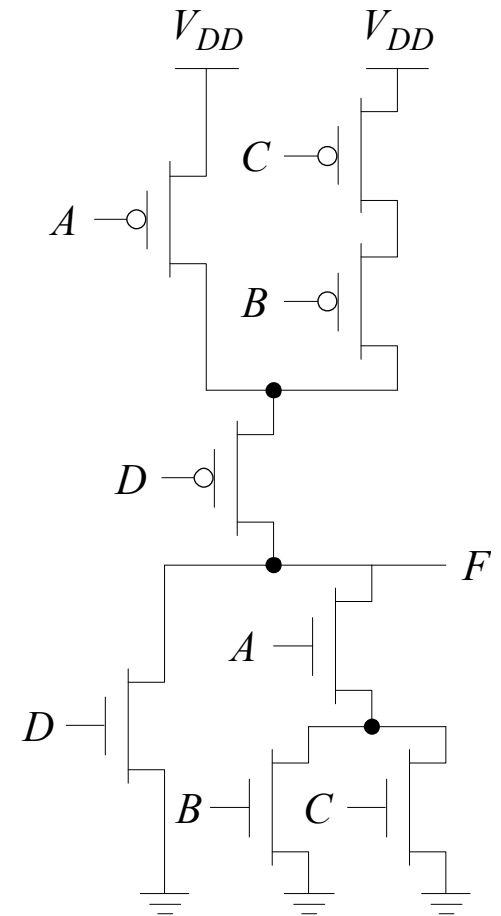

(c) complete gate

Find the equivalent inverter....

Transistor Sizing a Complex CMOS Gate

What sizing will lead to a 2:1 equivalent inverter?

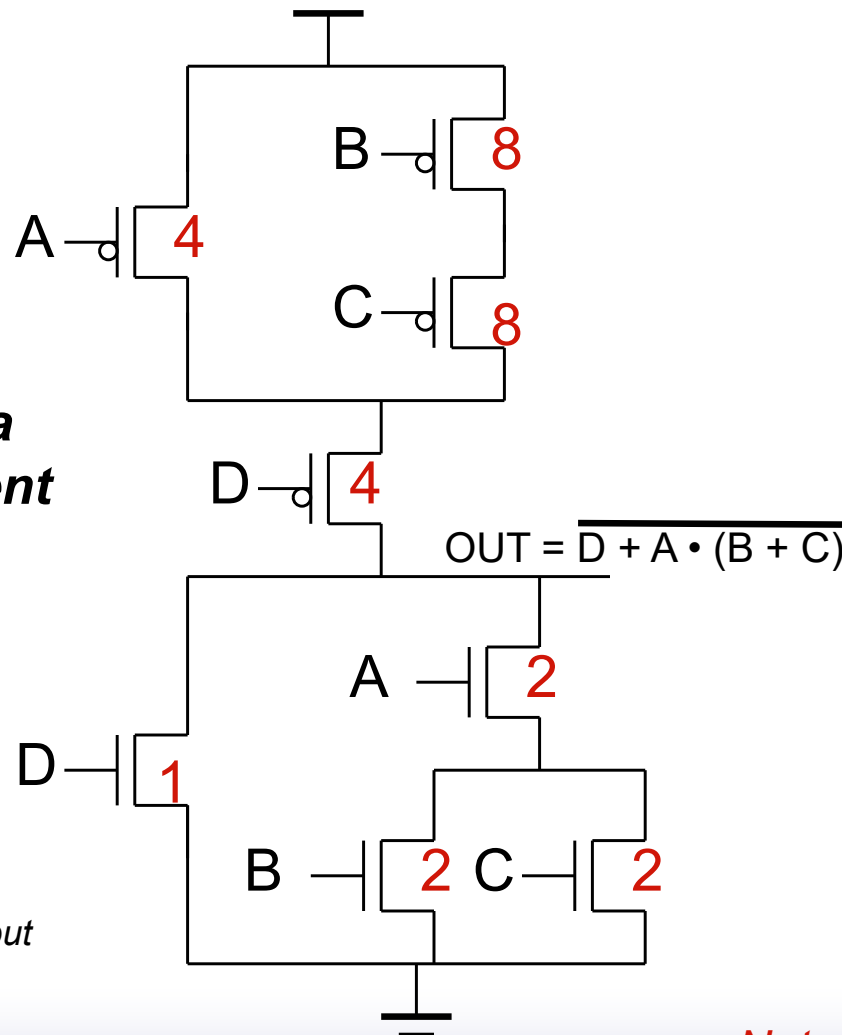

Note: A= 3 and B=C=D=6 will also give a 2:1 inverter but that will give higher output parasitic capacitance (due to larger D)

1. Start with a transistor in the PDN, that is (preferably) isolated (i.e., it can pull down the output node on its own)---D in this case
2. Assign a minimum size to this transistor (W=1 for D)
3. Now identify other paths in the PDN that can also discharge the output node: AB and AC in this case.
4. Size A, B, and C such that: each path will be electrically equivalent to the path through D (i.e., with same resistance), hence A, B and C should have W=2
5. Repeat the same for the PUN, keeping in mind that i) effective resistance of any path must equal the effective resistance of any path in the PDN, and ii) PMOS transistors will have to be sized (twice as large in this case) appropriately.

Note: here we ignored internal caps.

CMOS gate design: summary

□ Designing a CMOS gate:

- Find pulldown NMOS network from logic function or by inspection
- Find pullup PMOS network
 - By inspection
 - Using logic function
 - Using dual network approach
- Size transistors using equivalent inverter
 - Find worst-case pullup and pulldown paths
 - Size to meet rise/fall or threshold requirements

Fan-In Considerations

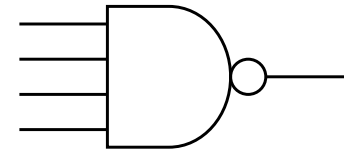
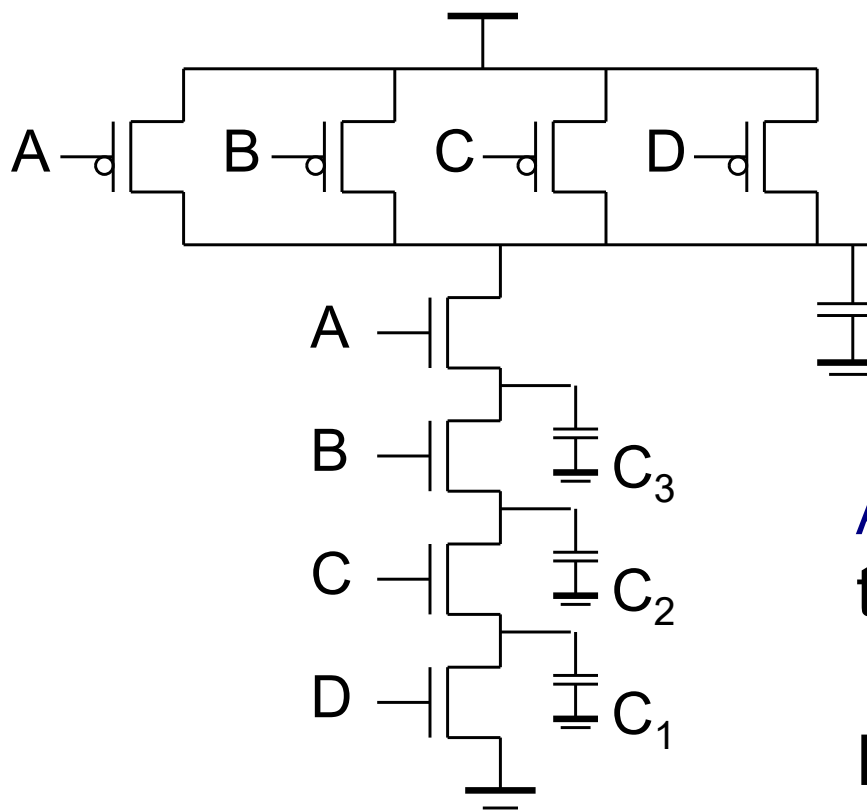

Distributed RC model
(Elmore delay)

Assuming all NMOS are equal size

$$t_{pHL} = 0.69 R_{eqn} (C_1 + 2C_2 + 3C_3 + 4C_L)$$

Propagation delay deteriorates rapidly as a function of fan-in – **quadratically** in the worst case.

t_p as a Function of Fan-In

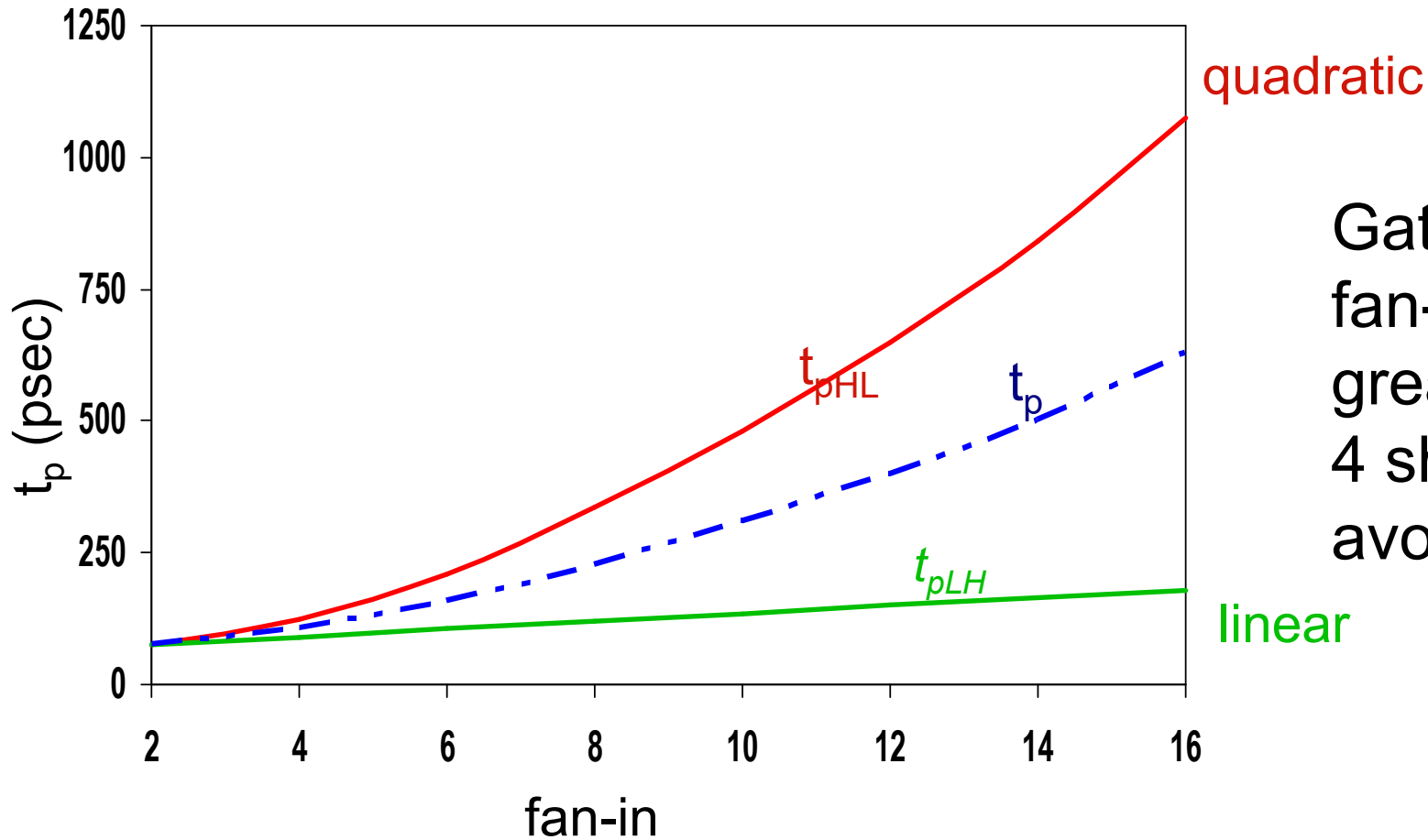

Gates with a fan-in greater than 4 should be avoided.

t_{pLH} increases linearly with fan-in.....

t_p as a Function of Fan-Out

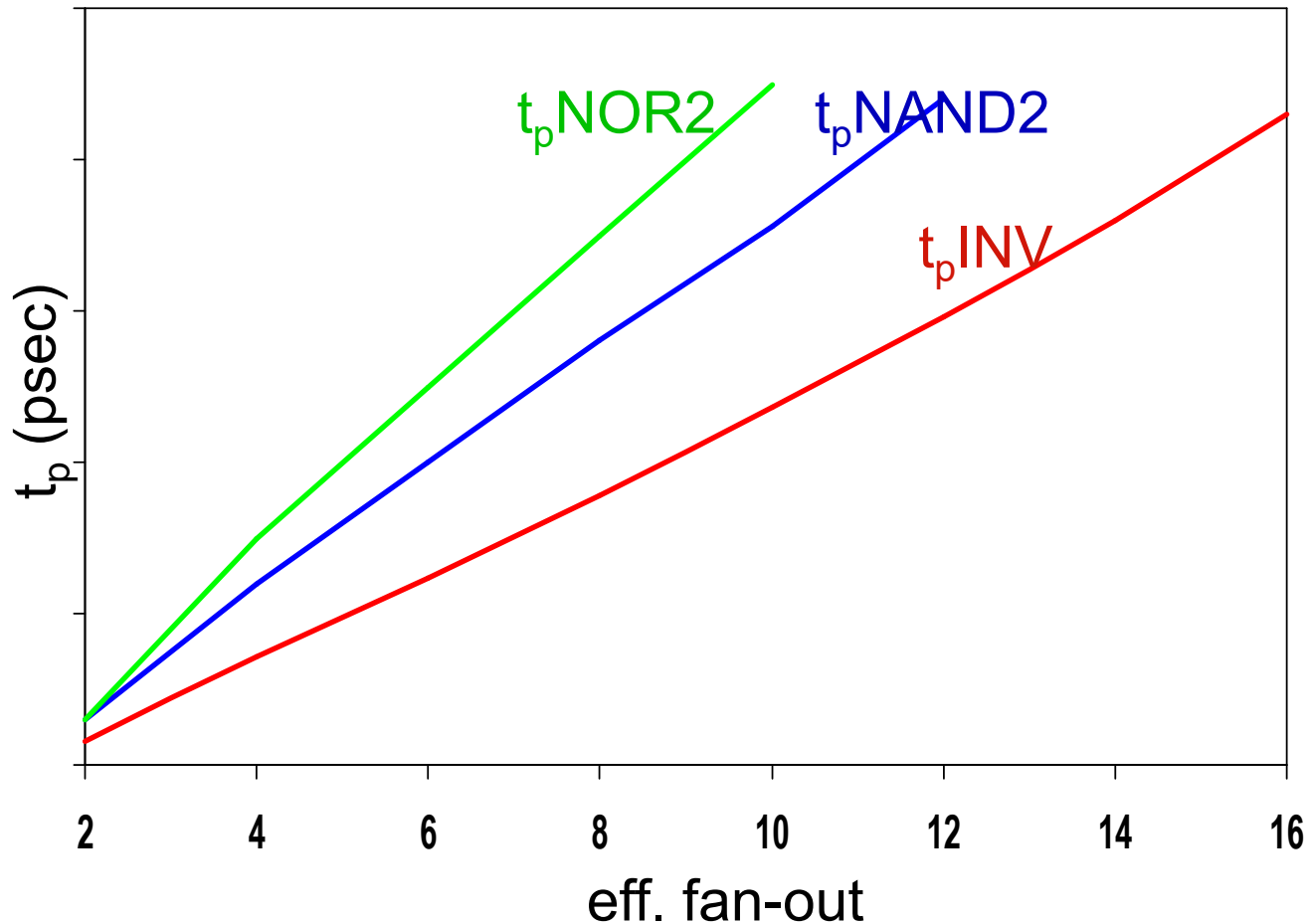

All gates have the same drive current.

Slope is a function of “driving strength”

Note: i) these lines are not going through the origin, ii) NAND and NOR have same intrinsic delay....

t_p as a Function of Fan-In and Fan-Out

- Fan-in: **quadratic** due to increasing resistance and capacitance
- Fan-out: each additional fan-out gate adds **two** gate capacitances to C_L

$$t_p = a_1 FI + a_2 FI^2 + a_3 FO$$

Common Static CMOS Gate Topologies

□ And-Or-Invert (AOI)

- Sum of products Boolean function
- Parallel branches of series connected NMOS

□ Or-And-Invert (OAI)

- Product of sums Boolean function
- Series connection of sets of parallel NMOS

Fast Complex Gates: Design Technique 1

- Transistor sizing
 - as long as fan-out capacitance dominates
- Progressive sizing (not so simple to layout!)

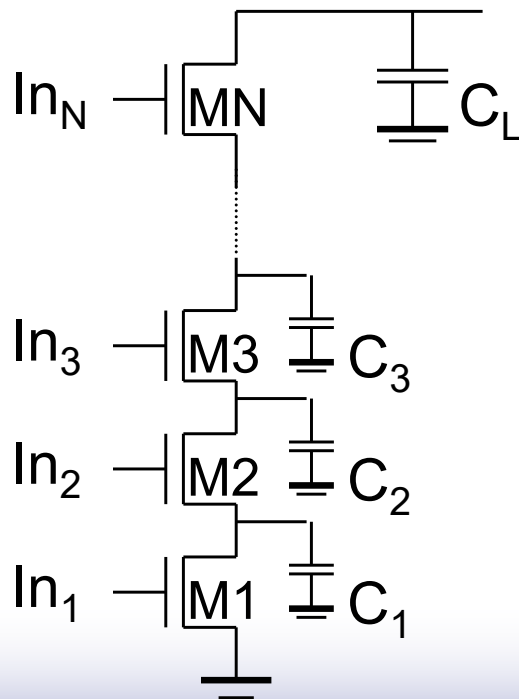

Distributed RC line

$M1 > M2 > M3 > \dots > MN$

(the transistor closest to the output is the smallest: has biggest R)

Can reduce delay by more than 20%; decreasing gains as technology shrinks

Fast Complex Gates: Design Technique 2

□ Transistor ordering

Critical path is determined by the slowest arriving signal: In1

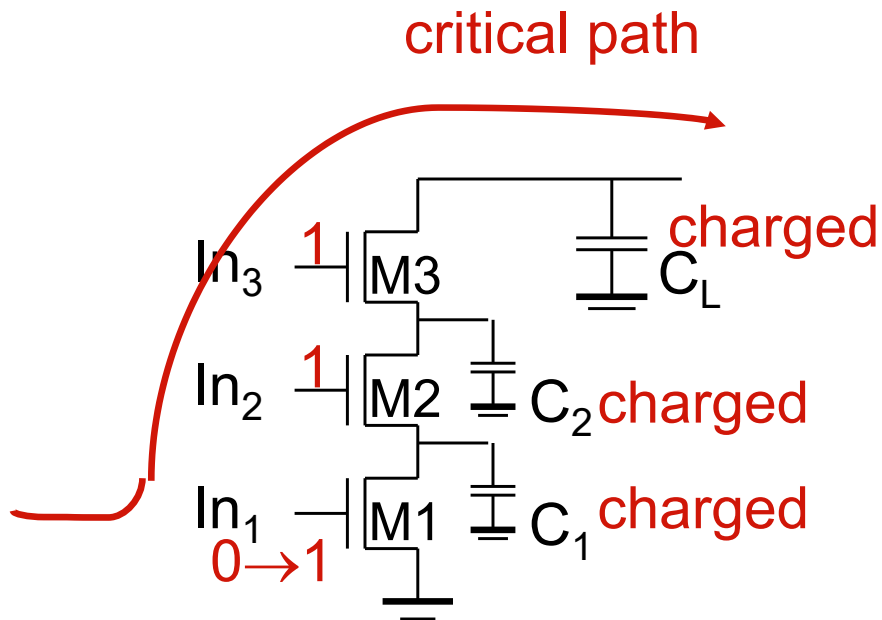

delay determined by time to discharge C_L , C_1 and C_2

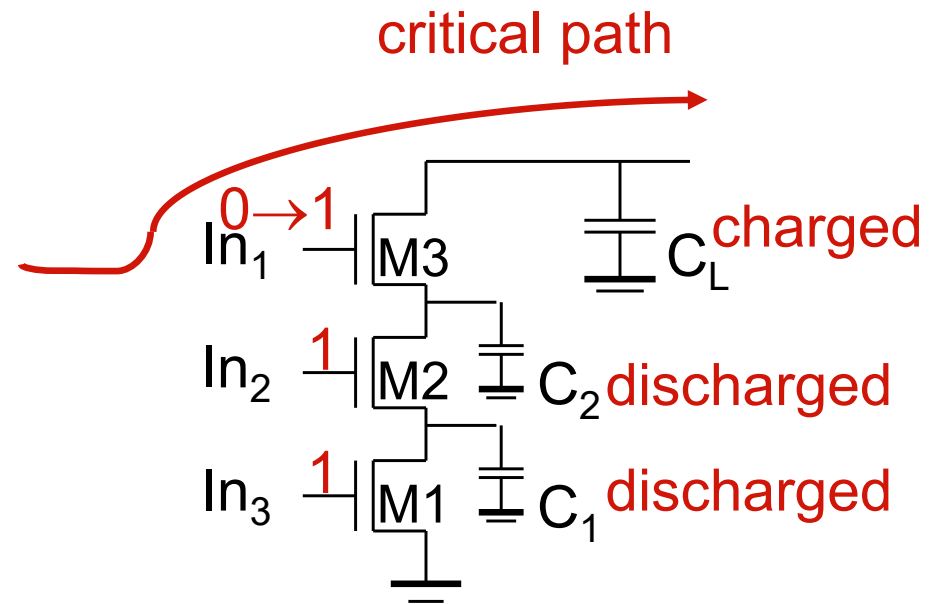

delay determined by time to discharge C_L

Fast Complex Gates: Design Technique 3

□ Alternative logic structures

$$F = ABCDEFGH$$

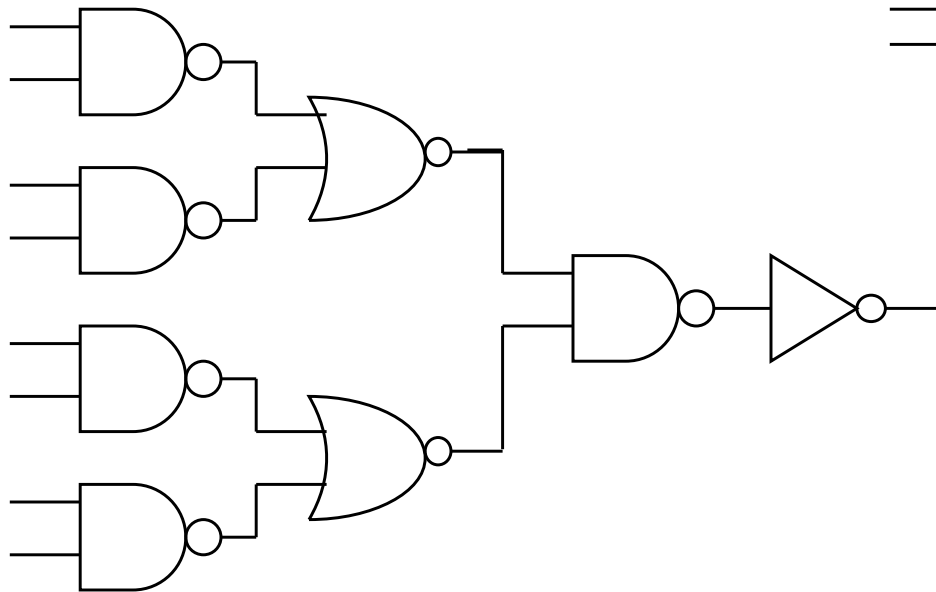

Using De Morgan's Law...

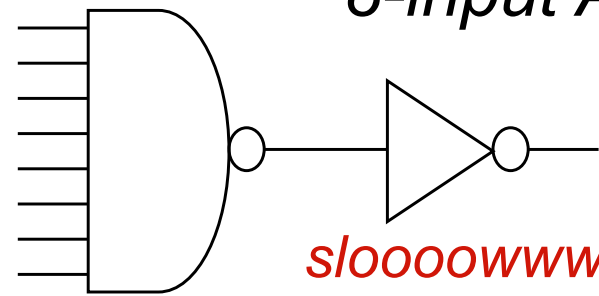

8-input AND

slooooooowww....

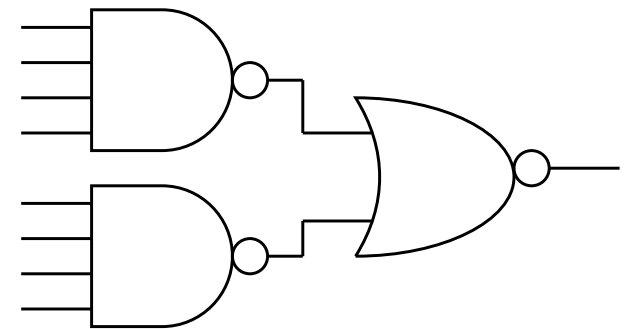

Fast Complex Gates: Design Technique 4

- Isolating fan-in from fan-out using buffer insertion

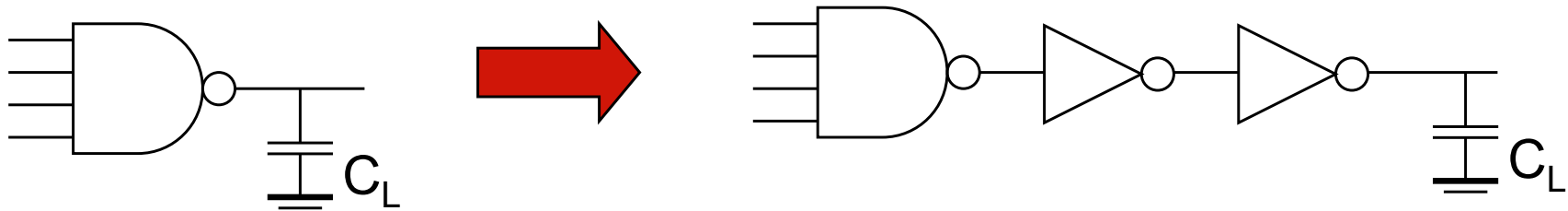

Fast Complex Gates: Design Technique 5

- Reducing the voltage swing

$$t_{pHL} = 0.69 (3/4 (C_L V_{DD}) / I_{DSATn})$$
$$= 0.69 (3/4 (C_L V_{swing}) / I_{DSATn})$$

- linear reduction in delay
 - also reduces power consumption
- But the following gate is much slower!
 - Or requires use of “sense amplifiers” on the receiving end to restore the signal level (memory design)

Revise CMOS gate layout....

- Goal: minimum area

- Method

- Minimize diffusion breaks (reduces capacitance on internal nodes)
- Align transistors with common gates above each other in layout (minimizes poly length)
- Group PMOS and NMOS transistors together

- Approach:

- Use Euler path method to find ordering of transistors in layout