



Weightless.  
Wait less.

**OVERVIEW**

In 2013, Elon Musk proposed a futuristic transportation system: the Hyperloop, a high-speed levitating pod propelled through a low pressure vacuum tube to minimize air drag and friction.

To bring the Hyperloop concept to life, SpaceX hosts a head-to-head competition where teams from all over the world come to compete with their own Hyperloop pod designs.

This year, the team is competing in the Levitation Competition, in which the pod must levitate and translate in a there-and-back lap down a 150 ft I-beam track. The fastest pod wins!

**THE SHELL**

- ◆ Stiff and lightweight carbon fiber serves as combined structural frame and aerodynamic shell
- ◆ Honeycomb core offers higher strength-to-weight ratio than carbon laminates alone

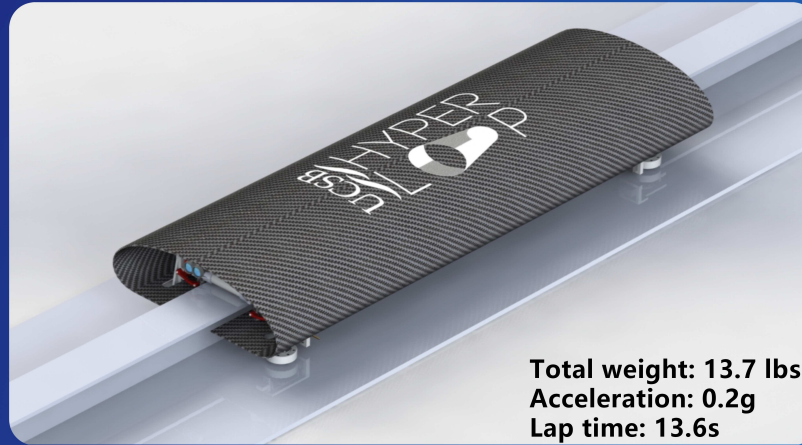
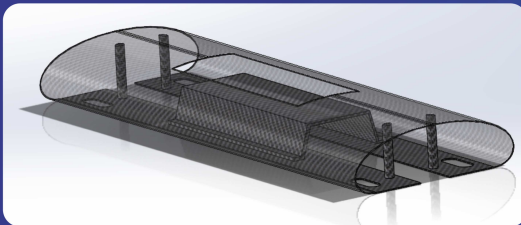

**ELECTRONIC CONTROLS UNDER THE SHELL**



**LIDAR**  
Uses laser to detect nearby wall and engage emergency

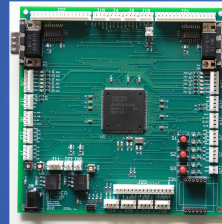

**PCB**  
Primary control unit and sensor monitoring system



**BMS**  
Monitors battery & protects from over-current and over-discharge



**IMU**  
Gives acceleration and rotation of pod in all 3 axes



**Battery**  
Lithium-Polymer



**GPS**  
Gives position of pod along I-beam in real time

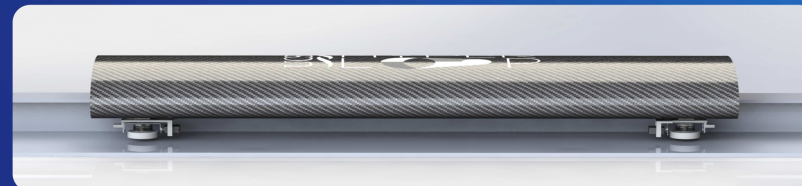

- Mechanical Engineers:**  
Andrew Chiang Edsel Pereyra Gavin Marcon Jackson Button  
Jack Dibachi Chin Su Liang Nathan Rudolph Wesley Carias  
Wesley Esko Xingchen Liu Zhijiong (Raymond) Huang  
Ryan Porteous Pedro May
- Electrical Engineers:**  
Rachel Reyes Himangshu Chowdhury Xiaochang Liu  
Mihir Shevgaonkar Jieyun Yang
- Computer Engineers:**  
Cameron Bijan Alex Jun Dylan Vanmali  
David Donaldson Mark Wu Ryan Loricca

**MAGNETIC LEVITATION**

- ◆ Four custom maglev hover engines generate lift and propulsion
- ◆ Servos control the tilt angle of the maglev engines for precise control of forward and reverse acceleration

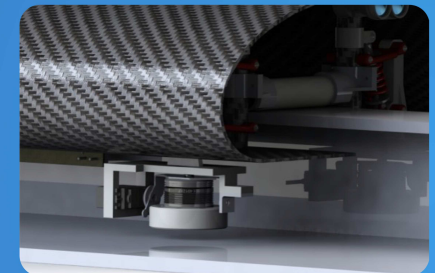

**STABILITY**

- ◆ Double wishbone vertical suspension stabilizes height, pitch, and roll
- ◆ Leaf spring suspension stabilizes yaw and lateral movement
- ◆ Failsafe brake skids safely bring the pod to a stop in the case of failure

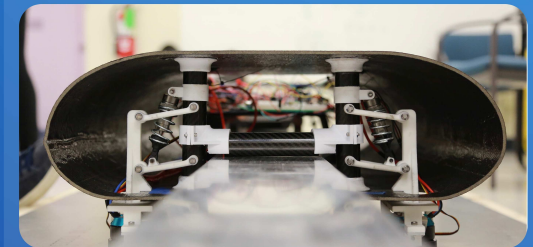

**ACKNOWLEDGEMENTS:** The team would like to thank our amazing mentors, advisors and sponsors for helping us throughout this project. Thank you to John Jacobs, Paul Hoff, Neil Smith, Tyler Susko, Ilan Ben-Yaacov, Yogananda Isukapalli, Roger Green, Andy Weinberg, Trevor Marks, Kirk Fields, Jonathan Siegel, Peter Carter, The Burros Family, Chris Wilkins, Giancarlo Garcia, Celeste Bean, and Brian Canty.



**Mechanical Engineers:**

Andrew Chiang Edsel Pereyra Gavin Marcon Jackson Button  
 Jack Dibachi Chin Su Liang Nathan Rudolph Wesley Carias  
 Wesley Esko Xingchen Liu Zhijiong (Raymond) Huang  
 Ryan Porteous Pedro May

**Electrical Engineers:**

Rachel Reyes Himangshu Chowdhury Xiaochang Liu  
 Mihir Shevgaonkar Jieyun Yang

**Computer Engineers:**

Cameron Bijan Alex Jun Dylan Vanmali  
 David Donaldson Mark Wu Ryan Lorica

**Shell Fabrication**

Weight: 2.6 lb

**Material:**

- ◆ Prepreg carbon fiber w/ honeycomb core
  - ◆ Pre-impregnated resin does not cure at ambient temperatures
- ◆ Hold resin at 250°F for 100 minutes to cure
- ◆ Honeycomb core between two plies of carbon offers a higher strength to weight ratio than solid carbon laminates alone

**Method:**

- ◆ Male plug constructed out of CNC'd MDF board cross sections [1]
- ◆ Plug coated with resin and block sanded to a smooth surface finish
- ◆ Two symmetrical female molds made out of molding material [2]
- ◆ Molds pulled off of plug and bolted together to form a complete mold [3]
- ◆ Carbon plies and honeycomb placed in mold, vacuum bagged, and cured in home-built oven [4] made from thermo foam and heat lamps

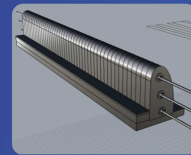

①



②



③



④



①

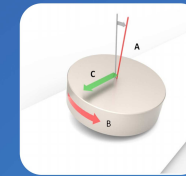

②

**Custom Maglev Specifications:**

- ◆ Max Voltage: 28.8 V
- ◆ Max Current: 24 A
- ◆ Max Power: 680 W
- ◆ 8 \* ½ inch cubic N52 Neodymium Magnets
- ◆ 3-inch diameter Delrin halbach array housing

**Magnetic Levitation**

**Levitation & Propulsion**

- ◆ The team designed, implemented, and tested the custom maglev hover engines which levitate and propel the pod.
- ◆ Permanent Magnets are arranged in a Halbach Array [1] which increases the magnetic field on one side.
- ◆ When Maglev Engineers spin, the oscillating magnetic field induces a repulsive or lift force in adjacent conducting rail.
- ◆ When tilting the engines, the drag force will become bigger on the side near the ground. The drag force makes the pod propel [2].
- ◆ The 40" dia test rig was constructed to measure lift and propulsion of the Maglev engines. Results are shown in the graph below.

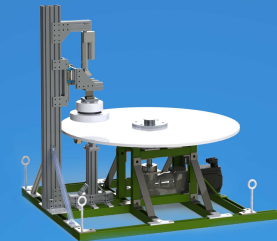

Test Rig

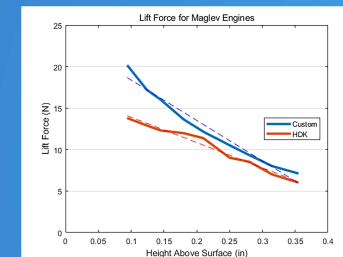
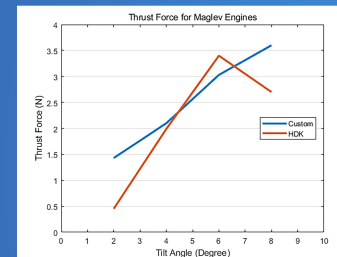

**Power System**

The power diagram illustrates how each component on the pod receives power and is grounded.

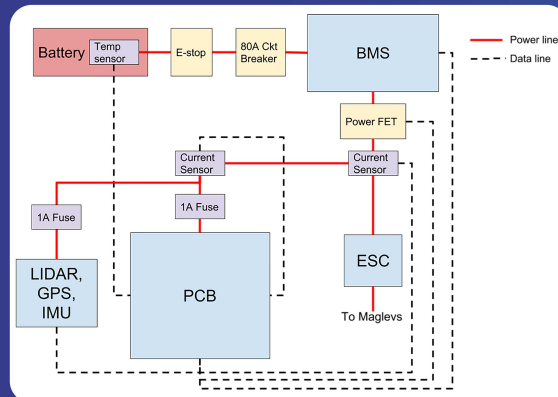

**Electronic Components:**

- ◆ LiPo (Lithium Polymer) battery (red) to power entire pod
- ◆ BMS (Battery Management System) to monitor battery health
- ◆ Mechanical emergency stop and electronically controlled power MOSFET (yellow) as active safety mechanisms
- ◆ 6V and 5V buck converters to convert power for PCB and sensors
- ◆ Circuit breaker and fuses (purple) to protect electronics from over-current
- ◆ Sensors for detecting current, battery temperature, pod position
- ◆ Universal ground plane (gray) to ground all electronics on pod

**PCB & Sensors**

Custom designed PCB (Printed Circuit Board) block diagram below

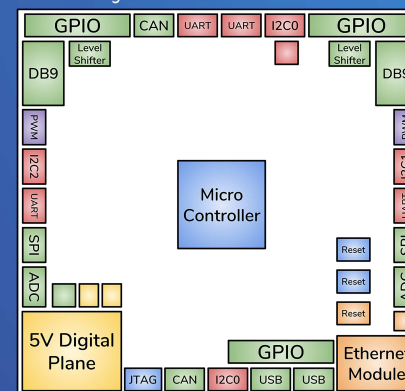

**Legend**

- Blue = Computing
- Red = Sensor Ports
- Purple = Motor Ports
- Yellow = Power
- Orange = Wireless Ports
- Green = Communication Ports

