

ECE 153B – Project Proposal

Morse Code Decoder

Richard Boone (8659963) & Sang Min Oh (9890922)

Section: W 7:00 PM – 9:50 PM

Overview

For this project, we will use the LPC4088 in order to create a device that decodes user-input Morse code and displays the corresponding alphanumeric character onto a LCD screen.

The Morse code will be input by a user via a push-button on the development board and an LED will help indicate whether a button press is registered. There are two types of inputs: a short push (which represents a Morse code dot) and a slightly longer press/hold (which represents a Morse code dash). The sequence of inputs will be decoded and the corresponding alphanumeric character will be displayed on the LCD. Multiple alphanumeric characters can be displayed on the screen at one time such that the display can show words. Another push-button is used to clear the screen.

Figure 1: General Circuit Diagram for the Morse Code Decoder

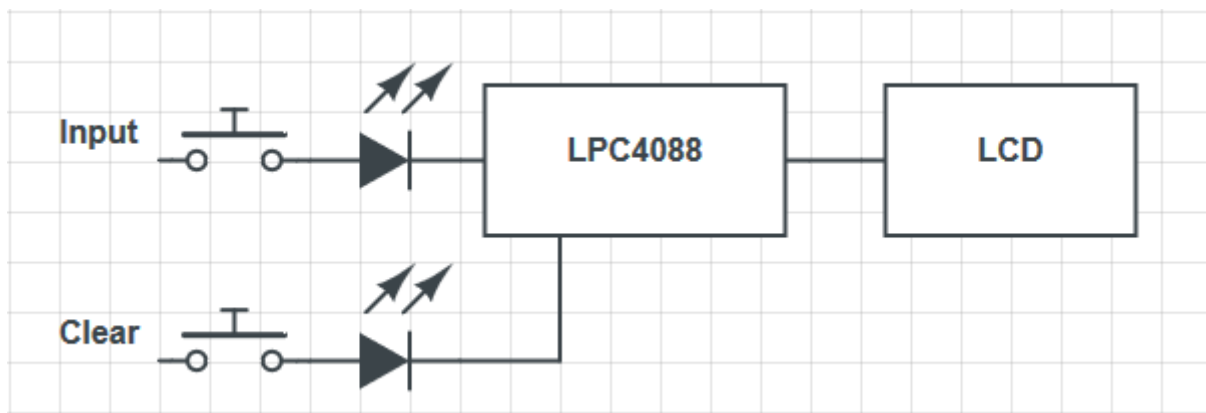

Peripherals

- LCD Screen
- Push-Buttons (on the development board) (x2)
- LEDs (on the development board) (x2)

Software Design

After initialization of the board, the program will enter an infinite loop in which it waits for a sequence of inputs to read. The loop must have code that:

- Detects an input sequence for a single alphanumeric character. There must be a maximum time limit for successive inputs that make up a sequence. The input sequence is encoded.
- Determines the alphanumeric character corresponding to the input sequence from a library (that we will write).
- Checks whether the “clear” button is pressed.
- Updates the LCD display accordingly.

Goals/Intermediate Milestones

- Accurately read the correct sequence of inputs and determine the correct alphanumeric character that corresponds to the input sequence.
- Display the correct alphanumeric character on the LCD screen. Allow the display of multiple characters on the LCD, with the characters going top-down, left-right with wrap-around.
- Clear the LCD and return to the initial blank display at the press of the “clear” push-button.
- In order to be able to write really short sentences/phrases, make custom encodings for a whitespace and several punctuation marks.

Individual Responsibilities

- Sang Min Oh will be responsible for reading the inputs from the push button with accuracy.
- Richard Boone will be responsible for applying the translation from accurate push buttons to letters and outputting these letters to the LCD