

ECE 153B – Final Project Proposal

Website: <https://sites.google.com/view/dog-treat-catapult/home>

Matthew Wong

Overview:

For this project, I plan to create a dog treat catapult that can be manually controlled or automated (provided that my dog is well behaved). Manual control is available either through a Wii Nunchuck connected to the catapult, or through a Termite terminal connected via Bluetooth. An ultrasonic sensor at the front of the catapult detects when the dog approaches, and launches a treat when she's within a set distance. One motor, positioned behind the arm, will hold the arm in place, and rotate out of the way to release the arm. The second motor, positioned toward the front of the assembly, will rotate to tension the spring attached to the arm. The catapult will be able to automatically fire and reset the firing mechanism.

As a stretch goal, I'd like to add a mechanism to automatically reload the catapult with treats. I'd also like to add mechanisms to rotate the entire catapult as well as change the release angle, all controlled via the Wii Nunchuck or Termite terminal. Due to time constraints and reduced manpower, these functions will be implemented only if time allows.

Peripherals:

- 2x Servo Motors
- HC-SR04 Ultrasonic Sensor
- DC Motor with H-Bridge controller (Stretch goal)

Serial Interface Protocols:

- I²C (Wii Nunchuck)
- UART (Bluetooth)

Block Diagram:

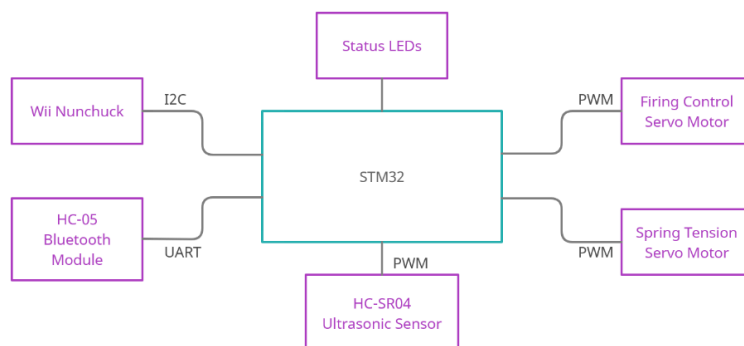

Responsibilities:

I am working by myself on this project, so I will be responsible for all aspects of it.

Software Structure:

The main loop of the program will handle the automatic firing function. Several flags need to be checked before firing, the mechanism must be ready, automatic firing must be enabled, and the ultrasonic sensor must have a distance measurement below 12 inches. Firing commands from the Wii Nunchuck and Termite terminal will interrupt the main process to fire the catapult regardless of the measurement from the ultrasonic sensor. The sensor can also be toggled on and off.