

ECE 153B Project Proposal

Website: <https://sites.google.com/view/ece153b0-landrover/history>

Overview / Goal:

The goal of this project is to build a working car that can be driven using computer inputs through wireless connection or by itself. To do this, we will be using the USART serial interface to send commands via bluetooth, I2C serial interface to communicate with the motors and accelerometer. We will also be using a sonar sensor to assist with the self driving mode.

Peripherals:

1. Sonar Sensor
2. Accelerometer
3. Bluetooth
4. Motors

Serial Interface Protocols:

1. USART
2. I2C

Block Diagram:

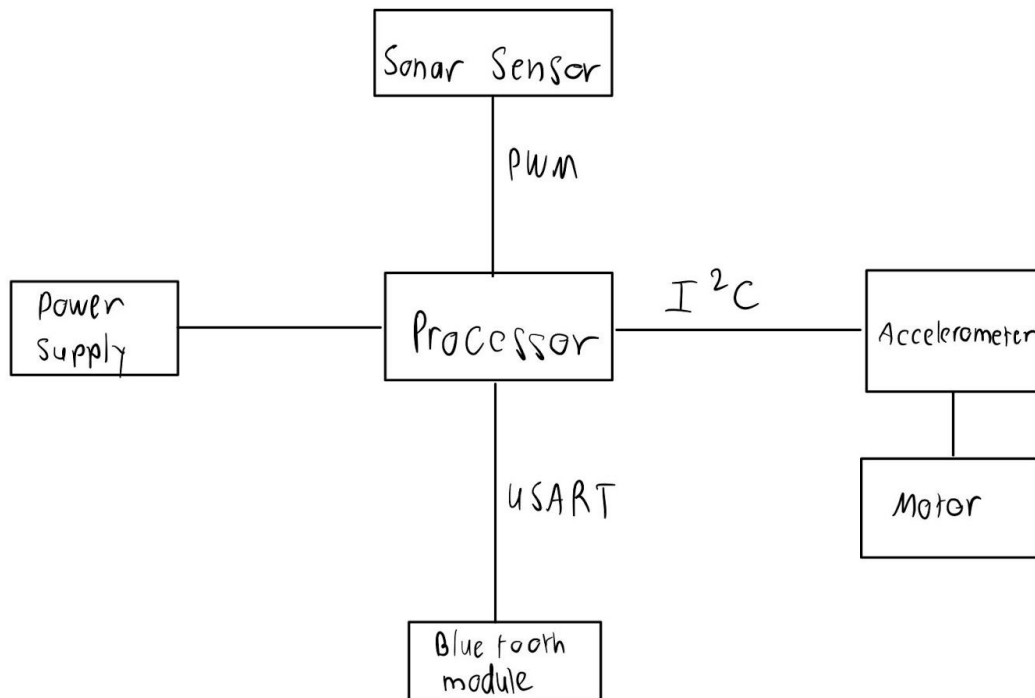

Responsibility:

1. Research motor and accelerometer: Nico and Thao
2. Reviewing and setting up USART and I2C: Nico and Thao
3. Reviewing and setting up Sonar Sensor: Nico and Thao
4. Coding the project: Nico and Thao
5. Updating the website: Nico and Thao

Software structure:

1. Upon startup, the board waits for commands from the terminal
2. If start command is sent, the board starts communicating with the motors, accelerometer, and sonar sensor
3. If car is in self driving mode, it moves by itself for 30 seconds and stops
4. Once 30 seconds is up, an interrupt flag is raised and the car will stop
5. If car is in remote controlled mode, it checks to see if an object is close ahead, if true, the sonar sensor will send interrupt
6. When interrupt is raised, the car will stop, move backwards and make a slight turn and continue moving
7. Car stops when a stop signal is received from terminal and will ignore all other signals until a start signal is sent from terminal again