

Project Proposal: SVM32

Nicholas Tran

Overview:

My goal is to recreate a retail sous vide circulator. This machine allows one to make a temperature-controlled water bath which is very useful for cooking food and keeping it warm. Sous vide also known as low temperature long time cooking allows food to be cooked at lower temperatures evenly to retain moisture and ensure safe cooking. The primary feature of this project will be creating a temperature-controlled water bath using a thermal sensor and a relay that will turn a water heater off/on. Alongside the heater, there is a water pump to circulate the water to prevent hotspots/coldspots in the bath. The secondary feature will be the use of Bluetooth to specify temperature and cooking duration where temperature will be the goal temperature of the water bath and cooking duration the time length for which the water bath will be maintained until it is shut off. The tertiary feature will be an LCD display to display the status of the cooking and any messages.

Peripherals:

- SHT20 I2C Temperature and Humidity Sensor
- SunFounder I2C LCD2004
- HiLetGo HC-05 Bluetooth Transceiver
- Digital Loggers IoT Relay

Serial Interface Protocols:

- I²C
- UART

Block Diagram:

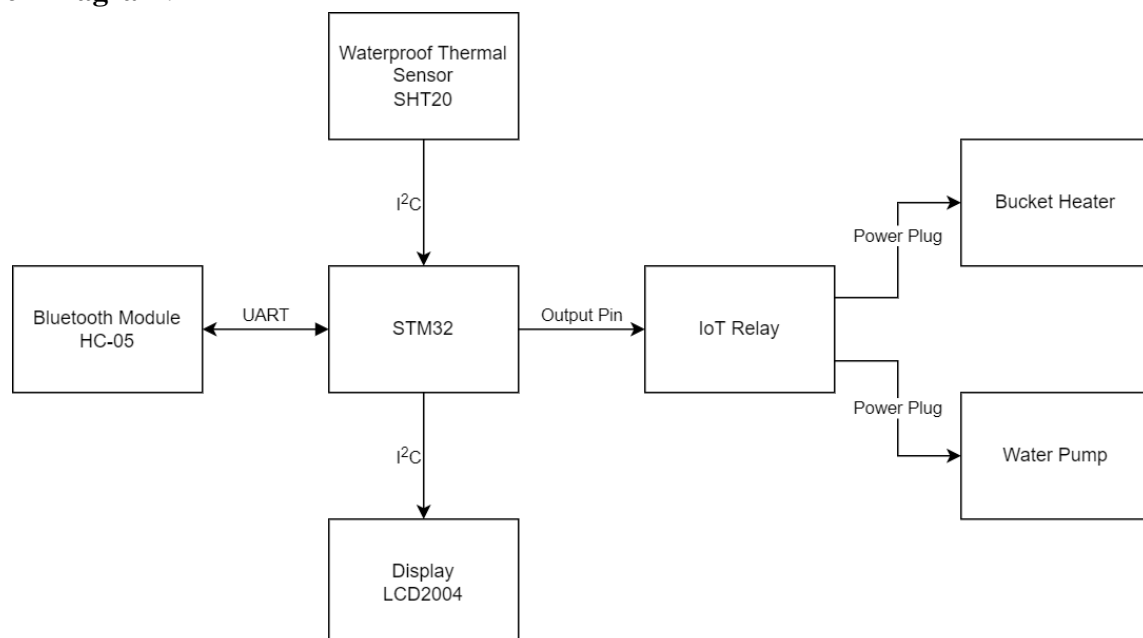

Responsibility List:

I am responsible for the whole project.

Software Structure:

The main control logic for this program is quite simple.

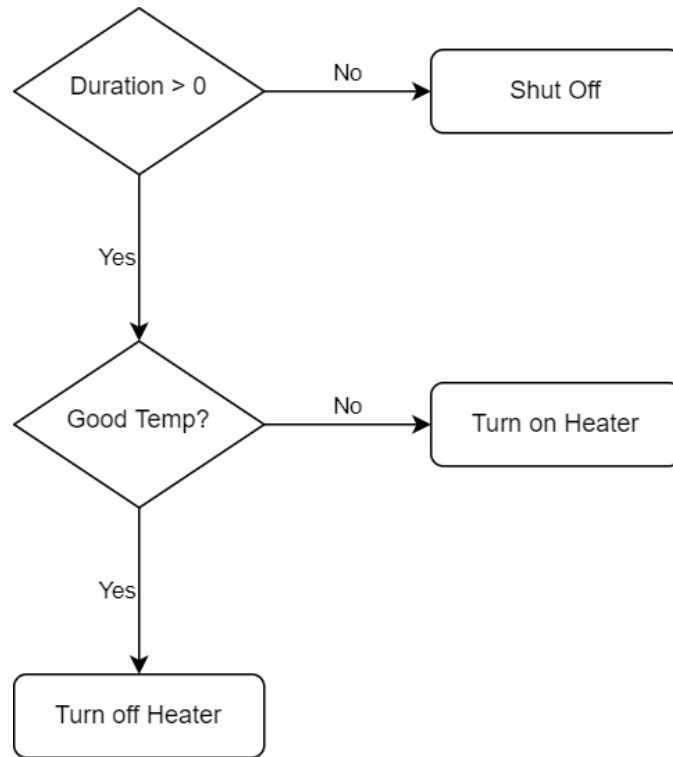

However, the implementation can end up tricky depending on how accurate I want the bath temperature control to be with its feedback loop. In addition to this, the software will handle Bluetooth interrupts to check for a stop/start command and any changes in settings to then take the appropriate action. The software will also display the current status of the program on the LCD.

Project Website: <https://svm32.github.io/>